

**Chapter 2**  
**WATER**

**1. General Requirements**

- a. Water system refers to water treatment, storage and transmission facilities for domestic, fire protection, commercial and industrial, irrigation, recreation and other uses.
- b. Treatment of water shall comply with Washington State Department of Health requirements.
- c. Any extension of the Port Townsend Water System must be approved by the Public Works Department and all extensions must conform to these standards, the Port Townsend Water System Plan, the rules and regulations of the Department of Health (Chapter 246-290 WAC), the Port Townsend Fire Department requirements, and the Washington Surveying and Rating Bureau (ISO).
- d. These standards apply to both the in-city and out-of-city water service areas.
- e. In designing and planning for any development, it is the developer's responsibility to see that adequate water for both domestic and fire protection use is attainable. The developer must show, in the proposed plans, how water will be provided, whether the existing system will be adversely impacted, and how adequate water will be supplied at the required pressures in case of fire. A detailed hydraulic analysis of the system may be required, if it appears that the system might be inadequate.
- f. Anyone that wishes to extend or connect to the city's water system should contact the Department of Public Works for preliminary information and discussion of the extension proposed. The design of a water system extension is the responsibility of the Developer proposing the construction and upgrading of the public water system.
- g. Prior to the installation of any water meters, all Public Works improvements must be completed and approved including granting of right-of-way or easements, and all applicable fees as set forth in Chapter 3.36 PTMC must be paid.
- h. Issuance of building permits for new construction of single family residences within new subdivisions shall not occur until final Public Works approval of all improvements is given, unless otherwise allowed through an approved improvement methods report and/or construction bond. For commercial projects, building permits may be issued upon completion and acceptance of the required fire protection facilities, providing the necessary easements have been filed and all required fees and connection charges paid. Certificates of occupancy will not be granted until final Public Works approval and acceptance of all improvements is given.
- i. Standard References
  - i. Except as otherwise superseded in these standards, water system design, installation, modification, and operation is subject to the "Rules and Regulations of the State Board of Health Regarding Public Water Systems," Latest Revision, WAC 246-290.

- ii. Water facilities design and construction shall conform to appropriate AWWA, and WSDOT/APWA Standard Specifications. In cases where conflicts exist between specifications, the order of precedence shall be City of Port Townsend Standards, AWWA and Washington DOT/APWA Standard's latest revisions.
- j. Warranty. The developer or owner shall warranty water lines and other water system improvements for one year after installation, approval and acceptance by the City and shall be responsible for one year for any unanticipated settling of excavations or repairs to restored street surfaces. All necessary repairs shall be performed immediately or the city shall perform the repairs at the developer's expense.
- k. Traffic Control: For work in opened streets and rights-of-way, the contractor shall follow procedures described in Chapter 1 of these standards.
- l. Approval for Construction Outside of Business Hours: Any work performed in any street right of way at any time other than Monday to Friday 7 am to 6 pm, must have the approval of the Public Works Department.
- m. Noncompliance Penalty: Utility development permits may be revoked from any contractor not complying with these specifications.
- n. Survey: See Chapter 1 of these standards.
- o. Standard Details: All construction shall comply with city Standard Details.

## 2. Design Standards

- a. The design of any water extension/connection shall conform to these standards and any applicable standards as set forth in other chapters of these standards.
- b. The layout of extensions shall provide for the future continuation and/or "looping" of the existing system as determined by the Director
- c. The following GENERAL CONDITIONS along with those in Chapter 1, shall be included on any plans for water system design and construction.
  - i. The city shall be given 72 hours notice prior to scheduling a shutdown of any portion of the water system. The existing valve must be pressure tested to city standards prior to connection. If an existing valve fails to pass the test, the contractor shall make the necessary provisions to test the new line prior to connection to the existing system or install a new valve.
  - ii. The existing valves shall only be operated by city employees during construction.
  - iii. During the construction of mains and services, the contractor shall cap, plug, or secure the ends of such lines whenever the project is shut down at the end of the day so that contaminants will not enter the lines.
  - iv. All lines shall be chlorinated and tested in conformance with the standard specifications. Dechlorination will be done by city forces at contractor expense.
  - v. All water mains shall be staked for grades and alignment.

## 3. Water Service Connections

- a. Connection Required Within City Limits. It is a requirement of the City of Port Townsend that all new development within the City limits must connect to the city water system. Wells for domestic use are prohibited.
- b. Out-of-City Service Area. In the out-of-city service area the city has the right of first refusal regarding water service. If the City elects not to provide water service, the applicant may seek service from another service provider in accordance with the adopted Coordinated Water System Plan (CWSP). City water service shall not be provided outside the city's currently adopted service area, unless a prior contractual obligation exists committing the city to provide service.

#### **4. Water Main Extensions and other System Improvements**

Water main extensions, replacements or other system improvements are required:

- a. Whenever a customer requests service and the premises to be served does not abut a water main;
- b. Whenever the existing water main(s) is not adequate to provide the necessary water pressure or flow requirements (including fire flow);
- c. Whenever system looping is necessary or where other components of the water system are inadequate to handle the increased water demands caused by the development;
- d. Whenever necessary to protect public health and safety; or
- e. Where indicated by the City's Water System Plan or the CWSP.

#### **5. Procedural Requirements**

- a. Public Works Technical Conference. Anyone wishing to connect to or extend the city's water system is encouraged to request a meeting with Public Works staff to obtain preliminary information of the location of existing facilities and to review water system extension requirements. A technical conference will generally be required for anyone proposing a main extension.
- b. Application for water service. Any person seeking to connect to the City's water system shall submit an application to the Public Works Department on forms provided by the city.
  - i. Information required for the water service application shall include:
    - (1) The name of the owner or agent and his or her mailing address, the street address or name of the premises to be served, and the legal description of the premises to be served.
    - (2) The purpose for which the water is to be used, the type of development proposed and the number of living units within the premises to be supplied. The applicant shall also designate all fixtures to be installed. Such information must be sufficient to determine the size of water service, cross-connection control requirements and fire flow requirements.
    - (3) A scaled site plan showing the proposed location for the service connection and meter.

- (4) Upon request by the director, a hydraulic analysis of the system used to serve the development.
  - (5) Any other information deemed reasonably necessary by the director to review the application for compliance with Title 13 PTMC and these Standards, or required by other provisions of the City's code, Department of Health requirements, SEPA, permit conditions, or city ordinance.
  - (6) The design drawings and specifications for the water system improvements required under "item e" below.
- ii. **Complete Application Required.** The city will not process any application unless and until the information required above is substantially complete. The public works director may reject an application as incomplete within a reasonable time of review, in which case the director shall return it to the applicant with an indication of the additional information needed to make the application complete.
- c. **Water Reservation for Out-of-City Service Area.** A water reservation application must be submitted on forms provided by the City for anyone located outside of the City limits but within the service area. Information required for the water reservation is included on the application form. If a water line extension or other water system improvement is required as a result of the development, engineered plans shall be prepared and submitted for review in accordance with "item e" below.
  - d. **Utility Development Permit.** A Utility Development Permit is required for any water main extension, replacement, and other system improvements in the City.
    - i. The Utility Development Permit shall contain all design drawings and information necessary for the Public Works Department to determine compliance with these Standards and the applicable codes and standards incorporated by reference into these Standards.
    - ii. When the City receives the application, the application will first be checked for completeness. Once it is determined to be complete the City will begin its review of the application.
    - iii. Utility Development Permits are reviewed and approved by the Public Works Department. Construction shall not commence until the permit is approved by the Director.
  - e. **Construction Drawings and Engineered Plans.** All applicants for water system connections and improvements shall furnish drawings and specifications necessary to describe and illustrate the proposed water system improvements. If base maps prepared by a licensed land surveyor are available, the design and construction plans shall be submitted on such maps. If base maps are unavailable, the public works director may require a survey to avoid conflicts with existing facilities, to determine elevations and contours, and to determine the right-of-way for utility placement.
    - i. All plans for main extensions and water system improvements shall be prepared, signed and stamped by a civil engineer licensed in the State of

- Washington.
- ii. For main extensions and replacements of 260 feet (one city block) or less in Tier 1 which do not require engineered plans under another authority of the PTMC, the developer has the option of the city performing the engineering for the fee identified in Chapter 3.36 PTMC. Alternatively, the developer may pay for his or her own engineering with the full cost to be borne by the developer.
- iii. All design and construction plans and specifications shall be prepared in accordance with current DOT/APWA standard specifications and the city's engineering design standards. If discrepancies exist in the standards and specifications, the city engineering design standards shall take precedence.
- iv. The requirement for engineered plans may be waived in certain instances as defined by the PTMC and approved by the City Engineer for minor improvements to the water system that can be adequately inspected and certified by the City Engineer, and that will still assure the long-term integrity of the water system. As-builts must be submitted for the project.
- v. All plans must be reviewed and approved by the Director prior to proceeding with construction.
- f. Inspection: All water system installations shall be inspected and approved by the City. It is the responsibility of the developer or contractor to notify the city 24 hours in advance of necessary inspections at the proper point in construction. All excavations must be left open until inspection is complete.
- g. Approval, Acceptance and Conveyance. Prior to installation of any water meters, all water system improvements must be completed and approved including granting of right-of-ways or easements, receipt of a bill of sale conveying the improvements to the City, and all applicable fees paid.
- h. As-Builts. Certificates of occupancy will not be granted nor final Public Works approval and acceptance of all improvements given until as-built drawings are received.

**6. General Facility Placement:**

- a. Underground facilities shall be located in accordance with applicable city ordinance and the utility location drawing in Chapter 6. Water mains shall be installed at a location which is compatible with the existing water system, the terrain, and the location of other utilities and so as to minimize present and future conflicts with sewer and storm drainage piping and improvements.
- b. All piping, pumping, storage, and other facilities shall be located on public rights-of-way or dedicated utility easements. Utility easements must be a minimum of 20 feet in width, and piping shall be installed no closer than 5 feet from the easement's edge unless approved by the city. Easements/rights-of-way for multiple utilities shall be a minimum of 25 feet wide.
- c. Generally, water and sewer lines shall be located on opposite sides of a street.
- d. There shall be no obstructions placed in a public right-of-way or utility easement

that restricts access to public water system lines and public fire hydrants.

**7. Distribution System - Flow and Pressure Requirements**

- a. Hydraulic Modeling. In designing and planning for any development, it is the responsibility of the developer to verify that adequate water for both domestic and fire protection use is attainable. The developer must show, in the proposed plans, how water will be provided, where other parts of the system will be adversely impacted, and how adequate water will be supplied at the required pressures in case of fire. A detailed analysis of the system may be required if it appears that the system is inadequate. Connection to the system may be denied if water pressures or flow are inadequate, unless replacement of inadequate lines is included with the proposed project.
  - i. All water system modeling shall be done using the City's water system data and its projected water demands at build out. Modeling shall be performed using the latest version of EPANET, unless an alternative modeling approach is approved by the Director.
  - ii. If modeling is necessary, the developer may pay the cost for the city to perform the modeling. Alternatively, the developer may use the City's model to perform the modeling, and the final result will be checked by the City.
- b. Minimum System Pressure: For all new developments or reconstruction projects, a minimum pressure of 30 psi shall be maintained throughout the distribution system at peak hourly demand (PHD) [WAC 246-290-230], except where booster pumps are allowed as provided under chapter 13.13 PTMC. Property owners are responsible for owning and maintaining booster pumps.
- c. Static Distribution Pressure Range: Whenever possible, static distribution pressures should range between 40 psi minimum and 80 psi maximum. Minimum static pressure must enable delivery of water to highest points in any zone at 30 psi during PHD conditions. The City may recommend or require that all services with static pressures at the service to the building in excess of 80 psi install individual pressure-reducing valves, per Uniform Plumbing Code requirements [UPC 608]. Property owners are responsible for owning and maintaining pressure reducing valves.
- d. Minimum Fire Flow System Pressure: In all new developments or reconstruction projects, a minimum pressure of 20 psi must be maintained throughout the distribution system when the required fire flow plus PHD is supplied. [WAC 246-290-230]
- e. Minimum Residential Fire Flow: Minimum fire flow for single family residential units is 1,000 gpm for 2 hours. [UFC Appendix III-A].
- f. Minimum Commercial Fire Flow: The fire flow for new or redeveloped commercial areas shall be a minimum of 1,500 gpm, for 2 hours, or as established by the Fire Marshal with jurisdiction for the project.
- g. Minimum Industrial Fire Flow: The fire flow for industrial developments shall be a minimum of 2,000 gpm for 2 hours, or as established by the Fire Marshal with

- jurisdiction for the project.
- h. Maximum Pipe Velocity: To avoid excessive head loss, pipe velocities should not exceed 10 feet per second at PHD.

**8. Service Installation or Service Connections**

- a. General
- i. All water service connections shall be made by city forces, except as approved by the director for projects which are not on live water lines.
  - ii. All service connections to the city water system shall be metered and all premises shall be separately metered.
  - iii. No service connections shall be made to transmission lines unless approved in writing by the director.
  - iv. Initial service connections shall be installed at the expense of the property owner.
  - v. Connections to Main. Each served premises must have a separate connection to a main *except* as approved by the director in the following instances:
    - (1) Where separate connection is impossible or impractical.
    - (2) Adjacent residential or commercial premises services may share a common connection to the main.
  - vi. Replacement of Buildings. When buildings are replaced by new buildings, the existing water service connection may be used unless determined by the director to be unacceptable, in which case a new water service connection shall be installed and the applicant shall pay fees as described in **Chapters 13.05 and 3.36 PTMC**.
- b. Sizing.
- i. The size of service connection and the main to the premises served shall be determined based on the Uniform Plumbing Code and these standards.
  - ii. Over-sizing. The city may require oversizing of any service connection to improve service to the customer; however, SDCs and base rates will be assessed on the basis of the service size required by the water demands of the premises.
  - iii. Change in Use. A change of use that increases water use may require a larger tap size and a new service connection, unless the existing service is adequate for the changed use, as determined by the director.
  - iv. Down-sizing. Upon payment of required fees and charges identified in **Chapter 3.36 PTMC**, the city will reduce the charges for a customer who makes an application and receives approval for a down-sizing of their meter effective the date payment is made.
- c. Service Taps: Service taps shall be installed to all designated building sites at the time of water main installation and before the street is paved. At its discretion, the City may install or cause to be installed water taps for undeveloped lots not part of the development proposal and/or existing customers at the time when a water main is extended in city streets. The developer or contractor shall

- coordinate construction installation with City crews.
- d. Service Connections: Service connections shall conform to the standard detail drawings in this chapter and to WSDOT/APWA Standard Specifications Section 7-15.

## 9. Distribution Mains

- a. Minimum Pipe Diameter: Every new water distribution main placed into service shall be 8 inches in diameter, unless a larger size is indicated by the Water System Plan or city engineering design standards; *provided however*, that a 4-inch pipe extending not more than 200 feet beyond a fire hydrant may be installed in a dead-end street if there is no foreseeable need for extending the water main to connect to other water mains or for improvement of water service or other hydraulic needs. Taps off existing 4-inch diameter lines may be allowed when fire flow requirements can be met to serve the property and if the customer signs a no-protest agreement for future improvements to the system.
- b. Pipe Materials: AWWA approved C900 PVC or Class 52 ductile iron pipe, unless other materials are approved in writing by the City Engineer.
- c. Distribution System Looping: New distribution mains of 500 feet or more should be looped with at least two connections into the existing grid and shutoff valves shall be provided as necessary for system isolation.
- d. Line Termination: Distribution mains shall be constructed along the frontage of the property and extended to the next street intersection for orderly development of the system. A valve is required at every termination. Valves and fire hydrants as well as bends in pipe which cause non-uniform forces must be restrained and provided with thrust blocks. Fire hydrants or blowoffs are required at terminations, unless waived by the City Engineer.
- e. Air Releases and Blowoffs: Mains shall be provided with appropriately sized air release assemblies at all high points and blow-off assemblies at all low points. In no case shall the location of blowoffs be such that there is a possibility of back-siphonage into the distribution system. Discharges from a blowoff valve shall be controlled to minimize undesirable impacts on nearby property and activity. Air release and blowoff assemblies shall be constructed in vaults with suitable drains and protection from potential contamination.
- f. Gate Valve Spacing: Gate valves shall be provided at every intersection of two mains and at intervals on straight pipe runs to facilitate shutdowns for maintenance. Unvalved lengths of pipe shall not exceed 500 feet in school, mixed use, commercial, or multi-family areas, and 800 feet in single-family residential areas, where customers are being served unless other lengths are determined by the Public Works Director.
- g. Corrosion Control: Depending upon individual site conditions, cathodic protection or other appropriate corrosion control measures may be required in the pipeline design.

## 10. Water and Sewer Main Separation Distance:



- a. Water mains shall maintain ten (10) feet horizontal and 18" vertical separation above sewers (sanitary sewer, storm sewer, or irrigation water). If ductile iron pipe is used for the new water main, horizontal separation may be reduced to three (3) feet and vertical separation may be reduced to 6" (outside to outside of pipe). Where an existing sewer is above a proposed water main, and the proposed water main must cross the existing sewer, the sewer shall be replaced with a 20 foot section of ductile iron pipe such that the sewer line joints are equidistant from the center of the new water main.
- b. Crossings. Where water and sewer lines must cross, a minimum vertical separation of 18 inches shall be maintained. The minimum cover for a water main may be reduced to 18 inches upon approval of the Director to provide as much separation as possible. The longest standard length of pipe shall be installed so that the joints will fall equidistant from any sewer crossing. In some cases where minimum separation cannot be maintained, it may be necessary to encase the water pipe and/or sewer pipe in a pipe or concrete. Concrete encasing shall not be used unless specifically approved by the City.

## 11. Fire Hydrants

- a. Fire Hydrants: All buildings connected to the city water system shall be served by fire hydrants. Maximum fire hydrant spacing shall be 500 feet in residential areas and 300 feet, or as directed by the Fire Marshall, in multi-family, mixed use, and commercial areas. [UFC Appendix III-B] Hydrants shall not be installed on mains less than 6 inches in diameter. Placements shall be made to provide unhindered access for fire hose connection and testing and maintenance.
- b. Testing of Fire Protection Facilities: All fire protection facilities shall be tested for operation upon initial installation.
- c. Painting: All hydrant barrels shall be painted yellow except for the caps which shall be painted in accordance with the following: red (0-499 gallons per minute (gpm)), orange (500-999 gpm), green (1000-1500 gpm), blue (greater than 1500 gpm). All standpipes shall be painted red.

## 12. Water Main Installation

- a. Locations of water lines shall be staked for city inspection prior to excavation.
- b. Minimum Pipe Cover: Minimum cover on all distribution mains less than 12 inches in diameter shall be 3 feet. Minimum cover on mains 12 inches and greater in diameter shall be 3.5 feet.
- c. Pipe installation shall conform to WSDOT/APWA Standard Specifications Section 7-11 and AWWA C600. Detection (locator) wire shall be installed during all pipe laying at the bottom of the excavation; the wire shall be insulated solid core, 14 gauge or larger.
- d. Alignment: Pipe alignment shall conform to WSDOT/APWA Standard Specifications Section 7-10.3(5). Under normal circumstances the actual pipe alignment shall not deviate from the design by more than 4 inches in either direction.

- e. Detector Tape Requirement: An acceptable metallic tape marked with appropriate information shall be used in all piping installations. Detectable pipe identification tape shall be installed 16 inches above pipe material along pipe center line.
- f. Appurtenances: Valves, hydrants, and other appurtenances shall be installed in accordance with APWA 7-12, 7-14, and AWWA C600 and with the city standard installation drawings.
- g. Joint Deflection: Joint deflection shall be no more than 80 percent of maximum deflections recommended by manufacturers.
- h. Concrete Blocking: The design of concrete blocking shall be based on available soil bearing pressure data.
- i. Hydrostatic Testing: A hydrostatic and pressure leakage test will be conducted on all newly constructed water mains, fire lines, fire hydrant leads, and stub-outs in accordance with WSDOT/APWA Standard Specifications Section 7-11.3(11) and AWWA C-600 specifications in the presence of the City Inspector.
- j. Disinfection and Flushing: All pipes, valves, service connections, reservoirs, and appurtenances shall be flushed and disinfected in accordance with the standards of the DOH, AWWA C601-68 and D105-80, and WSDOT/APWA Standard Specifications Sections 7-11.3(12) and 7-15. Disinfection water must be dechlorinated before discharging to water bodies, wetlands or storm sewers. Such discharges must meet all federal and state requirements.

**13. Materials Specifications**

- a. Pipe
  - i. Ductile Iron Pipe: Class 52, AWWA C-150; WSDOT APWA Standard Specifications Section 9-30.1(1)
  - ii. PVC Pipe: AWWA C-900 only, WSDOT/APWA Standard Specifications Section 9-30.I(5)
- b. Fittings
  - i. Ductile Iron Pipe: WSDOT/APWA Standard Specifications Section 9-30.2(1); MJ fittings
  - ii. PVC Pipe: AWWA C-900 only, WSDOT/APWA Standard Specifications Section 9-30.2(5); MJ fittings, no glue.
  - iii. Hot Taps: Stainless steel tapping sleeve, Romac only
- c. Valves and Appurtenances
  - i. Gate Valves: Resilient Wedge, AWWA C500
  - ii. Butterfly Valves: AWWA C504
  - iii. Backflow Preventers: Resilient seat, DOH approved, AWWA C605
  - iv. Standpipes: Standpipes shall be equipped with at least a 2-1/2 inch National Standard Thread connection port. An emergency port may also be installed on above ground facilities to the same specifications.
  - v. Valve Boxes: WSDOT/APWA Standard Specifications Section 9-30.3(4)
- d. Hydrants: AWWA C502; Mueller Model Century 200 with two 2-1/2 inch (National Standard Thread) side ports and one 4-inch (National Standard Thread)

- steamer nozzle with 4-inch Stortz adapter.
- e. Meters and Services
    - i. Meters: Sensus SR11, or approved equal
    - ii. Corporation Stops: Mueller Model number H1502H(1" & 3/4"; H9969 (1 1/2" & 2"), WSDOT/APWA Standard Specifications Section 9-30.6(2), IPT x 110
    - iii. Service Saddles: WSDOT/APWA Standard Specifications Section 9-30.6(1)
    - iv. Curb Stops: Mueller H-15175, or approved equal, with copper inlet and inside IP outlet. IPT x 110 compression
    - v. Meter Boxes: PVC or concrete meter box 16 inches by 22 inches by 12 inches.
    - vi. Service Pipes: WSDOT/APWA Standard Specifications 9-30.6(3); 3/4 inch or 1 inch Type (K) copper, or larger as necessary
  - f. Miscellaneous
    - i. Guard Posts: WSDOT/APWA Standard Specifications Section 9-30.5(6)
    - ii. Marker Post: WSDOT/APWA Standard Specifications Section 9-30.3(5)
    - iii. Thrust Blocking: AWWA C600
    - iv. Pipe Gaskets: AWWA C115 A1

#### 14. Cross Connection Control

- a. Cross connections to the City's water system are prohibited.
- b. Cross connection control shall be in accordance with WAC 246-290-490 et seq and the *Accepted Procedure and Practice in Cross Connection Control Manual* -- Pacific Northwest Section of the American Water Works Association, latest edition.
- c. Information on the City's cross connection control program is contained in the Cross Connection Control Policy Document which is available on request.

#### 15. Pump Stations

- a. Pump Station (General): Pump stations must be designed and installed to take into account pressure and hydraulics of distribution system, safety and aesthetics.
- b. Pump Station Design Life: Pump stations will be designed for a minimum useful life of 25 years for all equipment and structures.
- c. Pump Station Capacity:
  - i. with storage: Supply pump stations that pump directly to storage shall be designed to supply maximum daily demand (MDD). Redundancy that enables the station to supply the MDD with one pump out of service is required.
  - ii. to distribution and storage: Pump stations that pump to distribution and storage must be sized so that the combination of storage and pumping capacity can supply peak hourly demand (PHD) plus fire flow. The pump station capacity must be 25 to 50 percent greater than the required capacity to enable storage replenishment. The station and storage

- combination should have adequate capacity with the largest pump out of service. Station and storage combination should have adequate capacity with the largest pump out of service.
- iii. direct to distribution: Pumps stations supplying distribution directly shall be equipped with two fire pumps, each of which is capable of producing the maximum fire flow requirement. Domestic pumps within a direct distribution station must be capable of supplying the maximum instantaneous demand to the system. If appropriately sized hydro-pneumatic tanks are used, domestic pumps may be sized for the peak hour flow. At least one redundant domestic pump must be provided such that, with the largest pump out of service, the remaining domestic pumps can still provide the peak hour demand flow to the system.
  - d. Booster Pump Station: Booster pump stations for individual residences shall be equipped with shut-off switches such that they are incapable of reducing pressure below zero. A low pressure cut-off shall be installed on the suction side of the pump.
  - e. Emergency Power: Except as noted, all pump stations shall be provided with onsite emergency power. If the pump station supplies an area with no direct storage available, onsite emergency power sized for the design capacity of the station is required. When pumping to main city reservoirs, the capability to connect to a portable power supply must be available that would allow at least the largest pump in the pump station to operate during the longest power outage experienced in the area over the last 10 years, as determined by the local power supplier.
  - f. Noise Control: The following shall be provided for noise abatement and control:
    - i. All pump stations will be provided with adequate noise control to meet state noise guidelines.
    - ii. Pumps shall be housed in a concrete or equivalent structure with sound attenuation provided.
    - iii. Pump stations shall be located away from residences where feasible.
  - g. Alarms: Pump stations shall be provided with intrusion and shutoff alarms compatible with the city's SCADA system.
  - h. Maintenance: Spare parts commonly needed for pump station repairs shall be provided with the installation. Examples of commonly needed parts include packing glands or mechanical seals, bearings, motor starters, fuses, etc. Manufacturer's recommendations and/or city maintenance history shall be used to determine spare parts inventory requirements.



# City of Port Townsend - Public Works Department

## Standard Detail

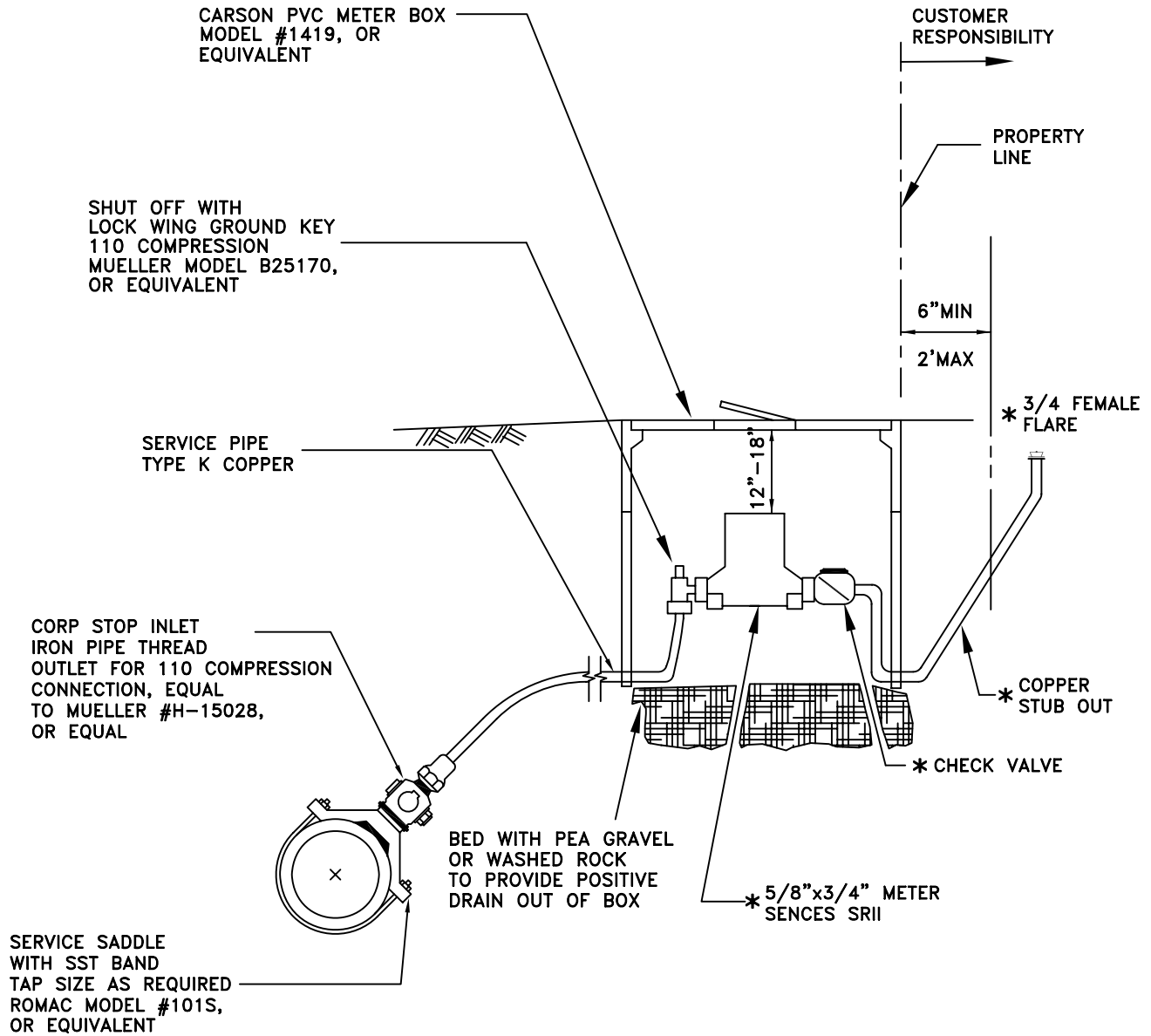

**NOTE:**

1. A PRESSURE REDUCING VALVE INSIDE A SEPARATE METER BOX IS RECOMMENDED WHERE STATIC PRESSURE IS GREATER THAN 80 PSI.
2. PRESSURE REDUCING VALVES SHALL BE INSTALLED ON CUSTOMERS PROPERTY AT LEAST 3' FROM THE WATER METER BOX.
3. SIZE OF FITTINGS AND TAP SIZE SHALL BE AS REQUIRED FOR THE TYPE OF SERVICE.
4. \* INDICATES ITEMS TO BE INSTALLED BY CITY.

Date: April 1997

Approved By:

File: E:\eng\_std\standard\water

No.	Date	Revision	By	Apvd

Water Service Connection  
Single 3/4" and 1" Service

Detail: W-1A



# City of Port Townsend - Public Works Department

## Standard Detail

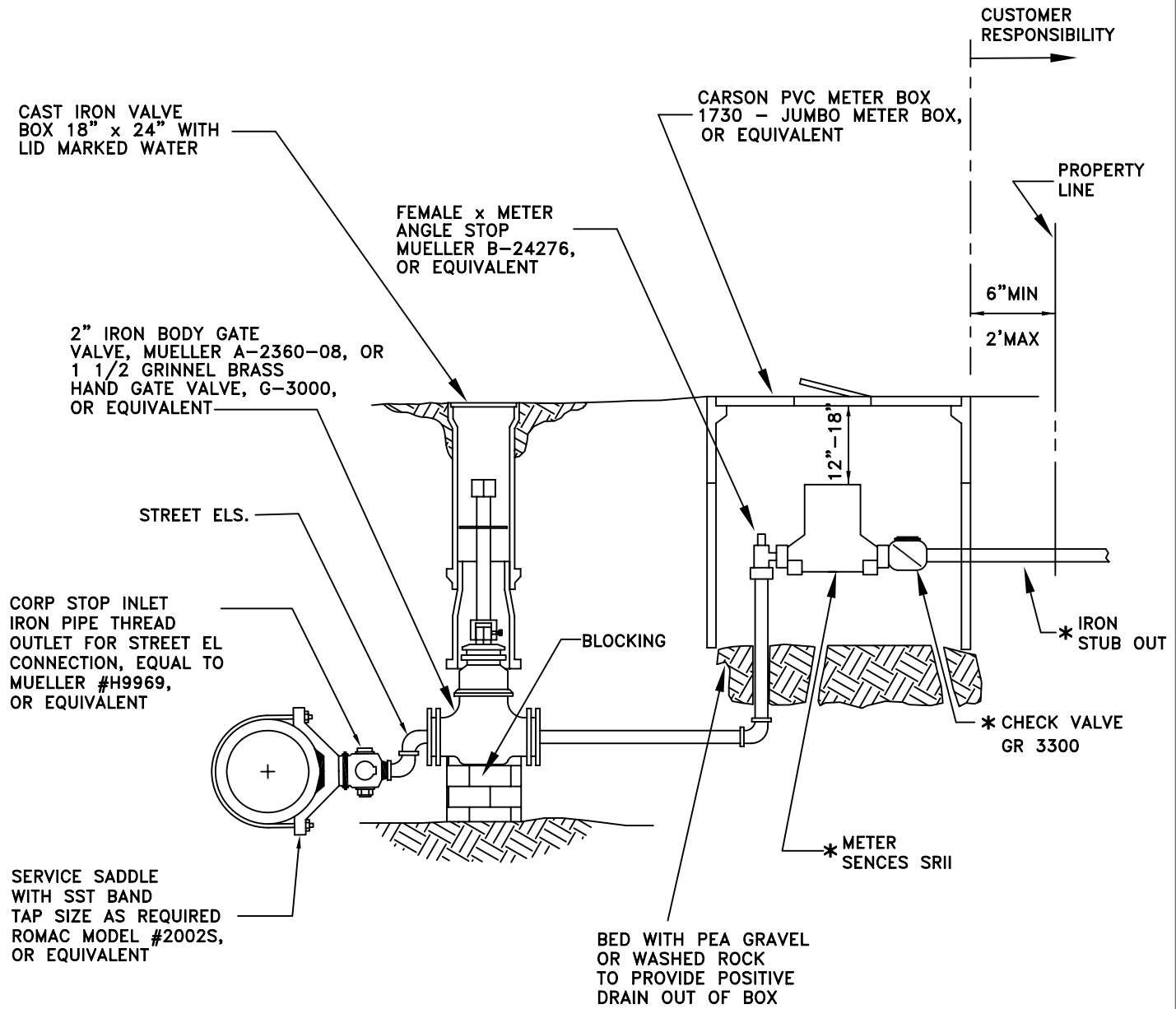

**NOTE:**  
 1. \* IDICATES TO BE INSTALLED BY CITY.

Date: April 1997	No.	Date	Revision	By	Apvd	<b>Water Service Connection</b> Single 1 1/2" and 2" Service  <b>Detail:                    W-1B</b>
Approved By:						
File: E:\eng_std\standard\water						



# City of Port Townsend - Public Works Department

## Standard Detail

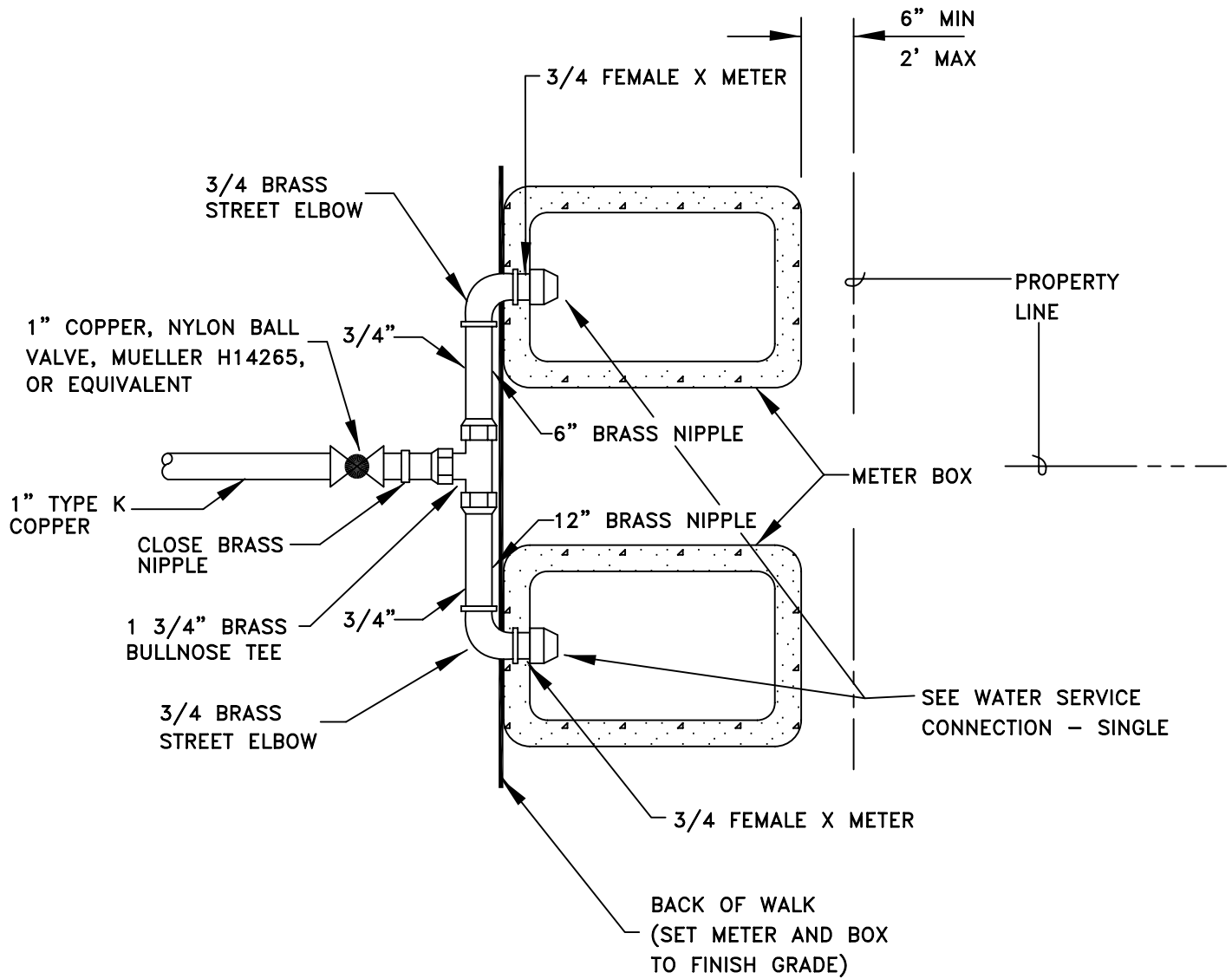

Date: April 1997	No.	Date	Revision	By	Apvd	<b>Water Service Connection</b> <b>-Double</b>  <b>Detail:                      W-2</b>
Approved By:						
File: E:\eng_std\standard\water						



# City of Port Townsend - Public Works Department

## Standard Detail

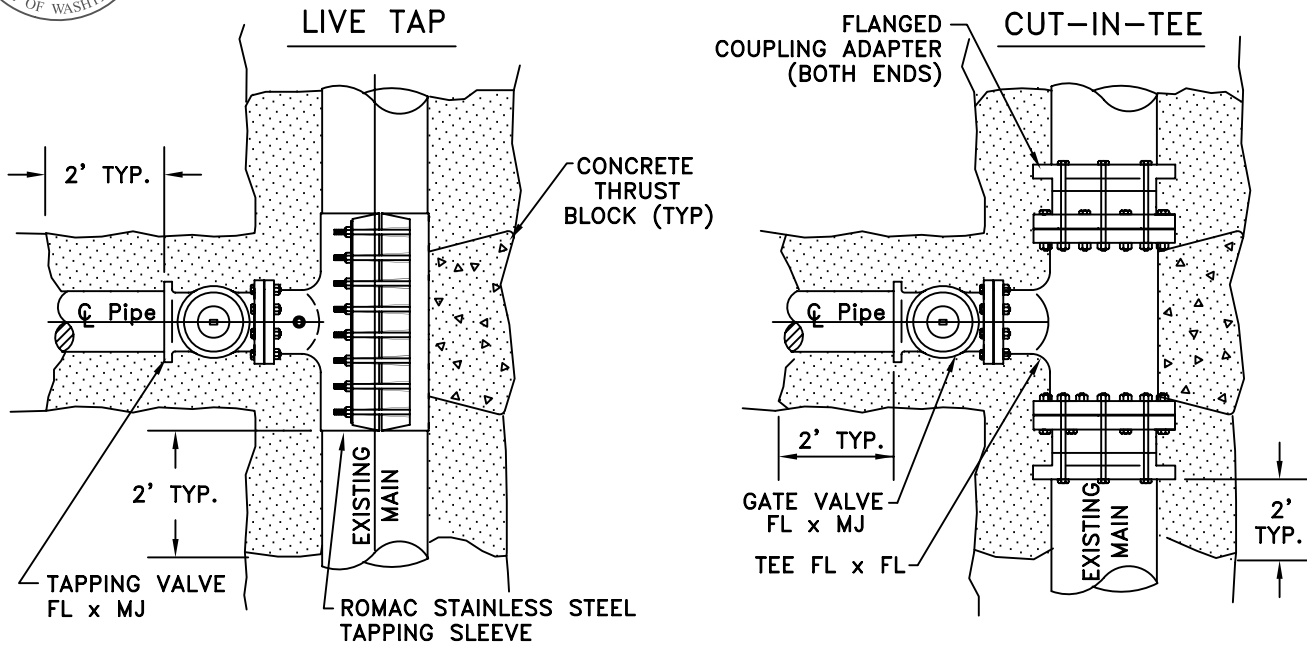

VALVE AND SLEEVE SHALL BE SUPPORTED AND BACKFILLED AS SHOWN BELOW—RIGHT.

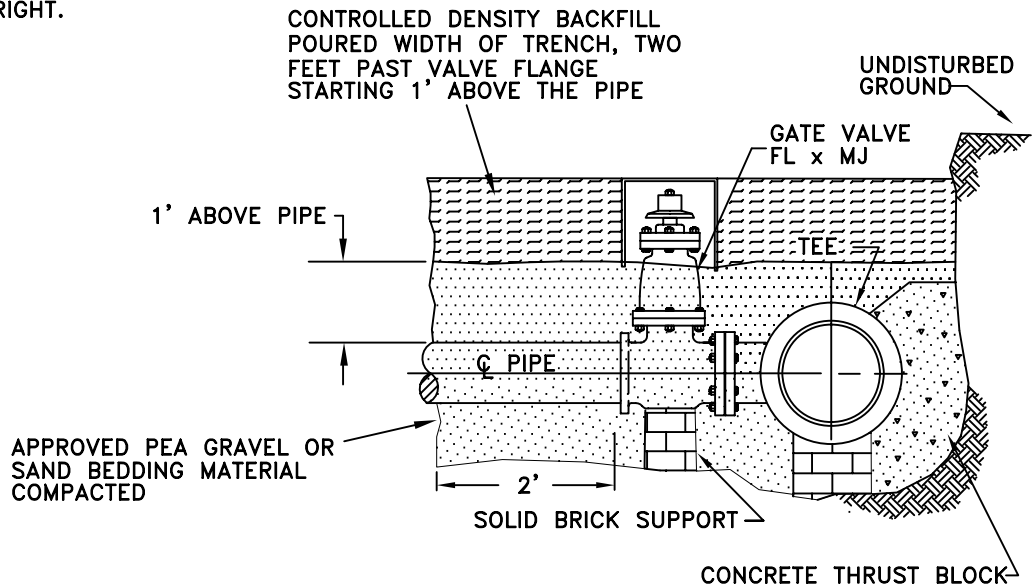

**NOTE:**

1. 11 MIL PLASTIC OR CONSTRUCTION FABRIC SHALL BE WRAPPED AROUND PIPE AND FITTINGS BEFORE THRUST BLOCK AND BACKFILL ARE Poured.
2. CONTROLLED DENSITY BACKFILL IS A PLANT MIX CONSISTING OF: 3100# SAND, 450# WATER, AND ONE SACK (94#) OF CEMENT.
3. MJ CUT IN TEES SHALL NOT BE PERMITTED.
4. SUPPORT VALVE AND SLEEVE CONTINUOUSLY THROUGH INSTALLATION.
5. ALL THRUST BLOCKS TO BE PLACED AGAINST UNDISTURBED GROUND.
6. FOR ROAD REPAIR SEE STREET STANDARDS.

Date: April 1997	No.	Date	Revision	By	Apvd	Connection to Existing Main  Detail:                      W-3
Approved By:						
File: E:\eng_std\standard\water						





# City of Port Townsend - Public Works Department

## Standard Detail

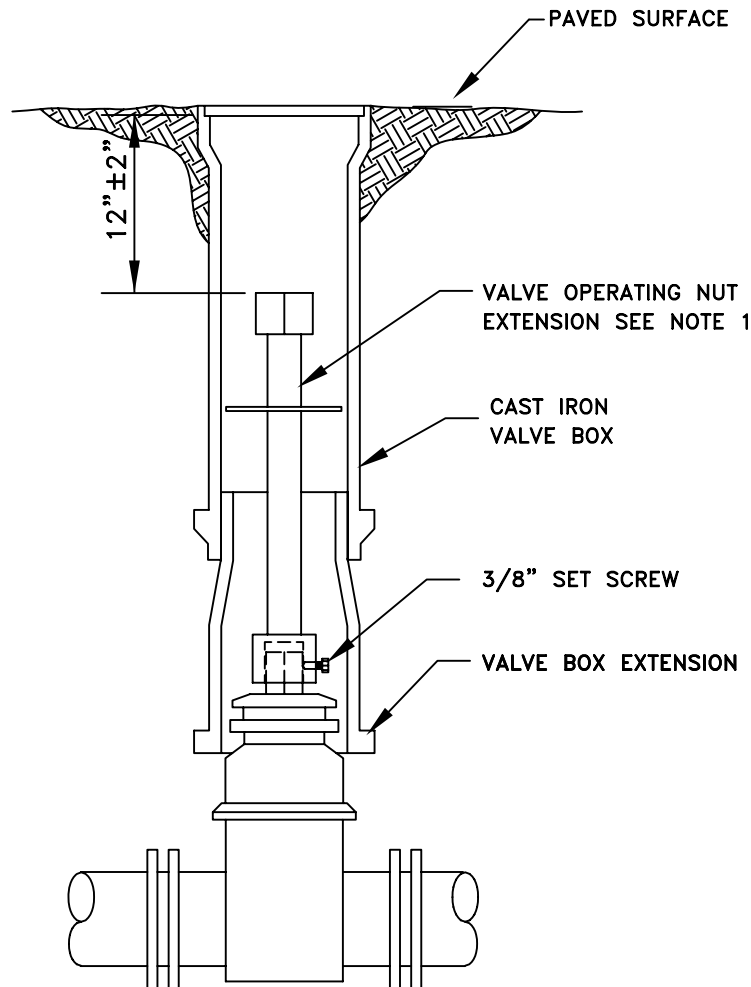

VALVE BOX AND EXTENSION

**NOTES:**

- 1 VALVE OPERATING NUT EXTENSIONS ARE REQUIRED WHEN THE VALVE NUT IS MORE THAN TWO (2) FEET BELOW FINISHED GRADE. EXTENSIONS ARE TO BE A MINIMUM OF ONE (1) FOOT LONG. ONLY ONE EXTENSION WILL BE ALLOWED PER VALVE.

Date: April 1997	No.	Date	Revision	By	Apvd	Valve Box and Extension  Detail:                      W-4
Approved By:						
File: E:\eng_std\standard\water						



# City of Port Townsend - Public Works Department

## Standard Detail

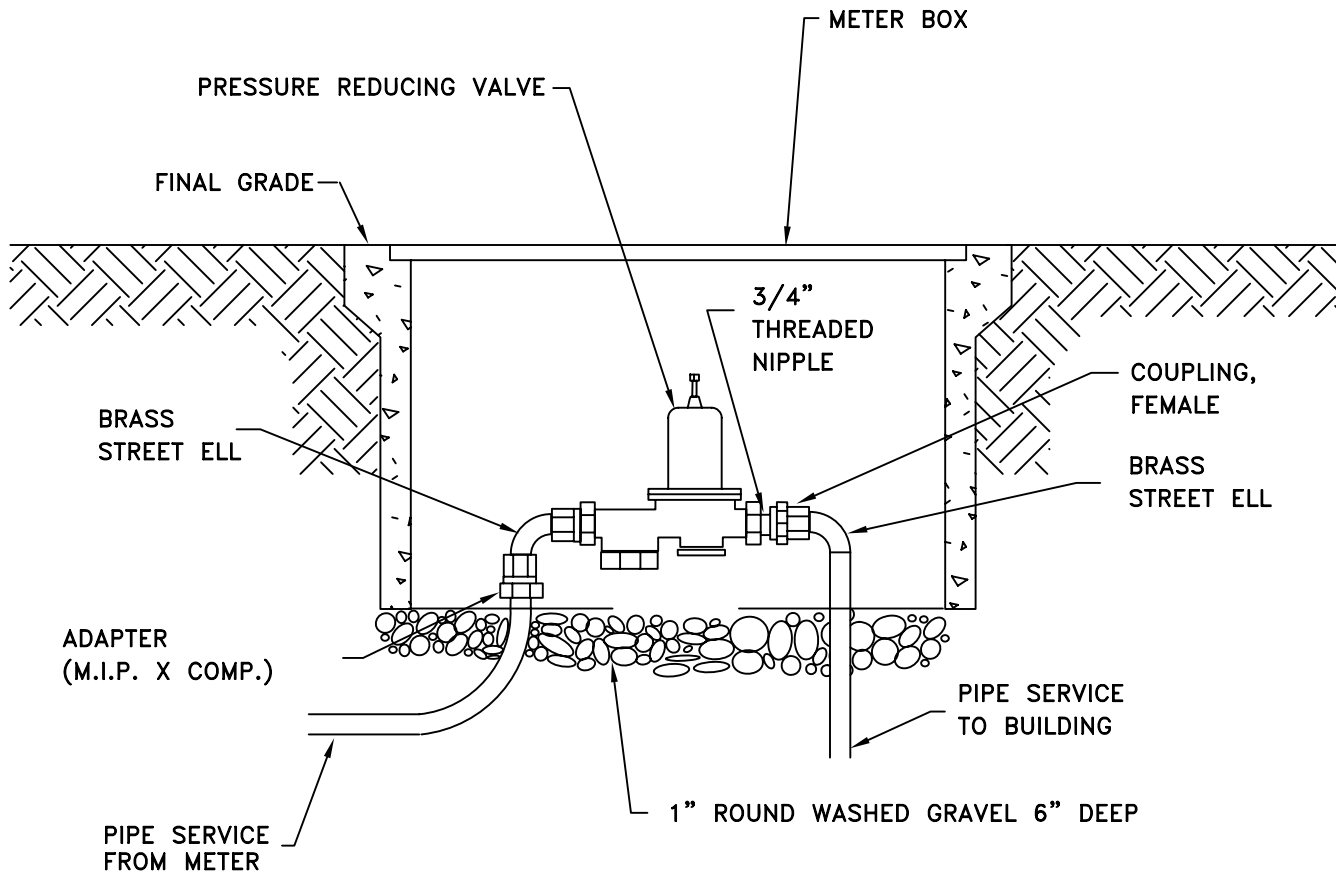

**NOTE:**

PRESSURE REDUCING VALVE INSTALLATION AND MAINTENANCE ARE THE COMPLETE RESPONSIBILITY OF THE CUSTOMER. THIS DETAIL IS PROVIDED FOR THE INFORMATION AND CONVENIENCE OF THE CUSTOMER ONLY.

Date: April 1997	No.	Date	Revision	By	Apvd	<h3 style="margin: 0;">Standard Pressure Reducing Valve Assembly</h3> <p style="margin: 10px 0 0 0;">Detail: <span style="float: right;">W-5</span></p>
Approved By:						
File: E:\eng_std\standard\water						



# City of Port Townsend - Public Works Department

## Standard Detail

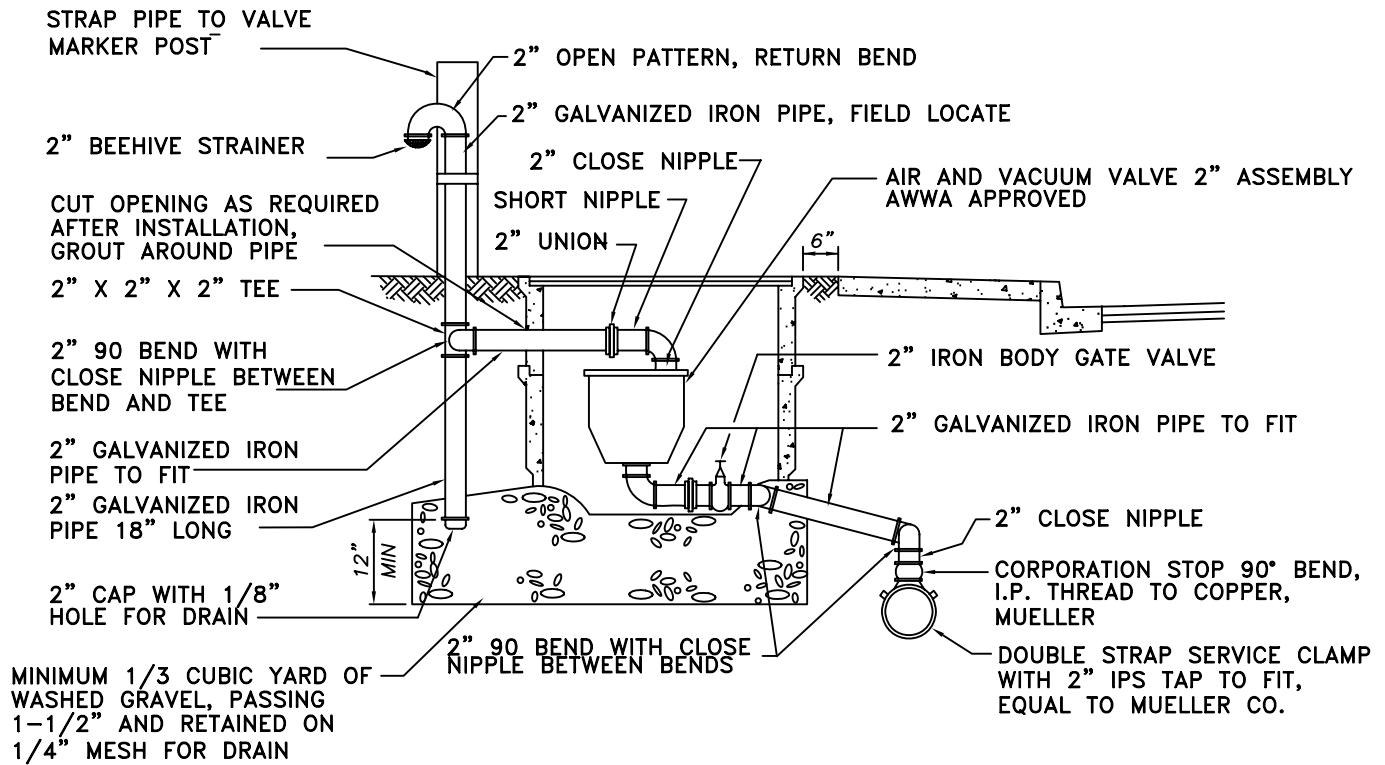

**NOTE:**

AIR AND VACUUM RELEASE VALVE ASSEMBLY SHALL BE INSTALLED AT HIGHEST POINT OF LINE. IF HIGH POINT FALLS IN A LOCATION WHERE ASSEMBLY CANNOT BE INSTALLED, PROVIDE ADDITIONAL DEPTH OF LINE TO CREATE A HIGH POINT AT A LOCATION WHERE ASSEMBLY CAN BE INSTALLED.

Date: April 1997	No.	Date	Revision	By	Apvd	<b>Combination Air Release/ Air Vacuum Valve Assembly</b>  <b>Detail: W-6</b>
Approved By:						
File: E:\eng_std\standard\water						



# City of Port Townsend - Public Works Department

## Standard Detail

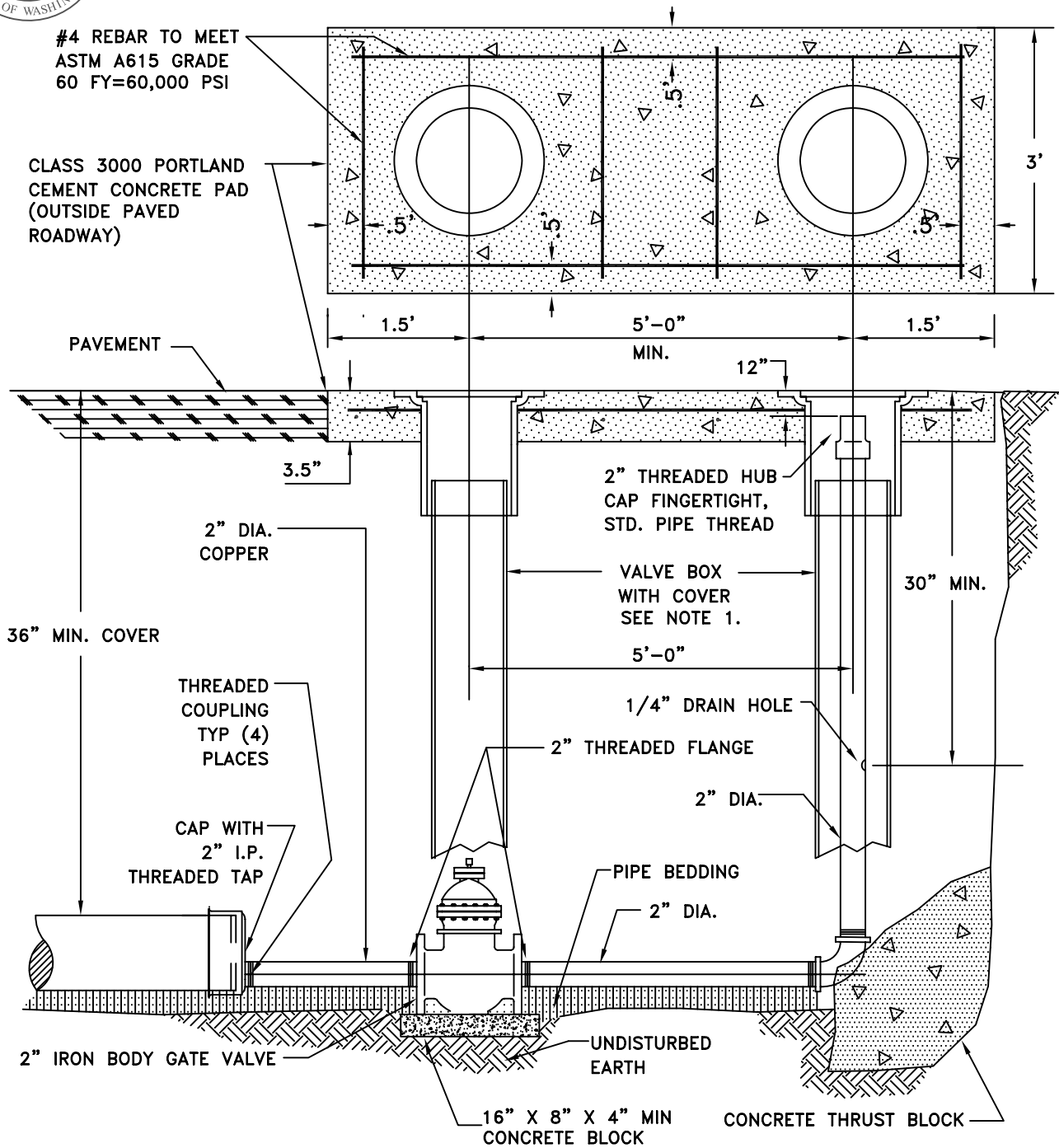

**NOTE:**

1. VALVE AND METER BOX COVERS SHALL BE PER STANDARD DETAILS.
2. CONCRETE PAD MAY, WITH CITY APPROVAL, BE DELETED.

Date: April 1997

No.	Date	Revision	By	Apvd

Approved By:

File: E:\eng\_std\standard\water

Permanent  
2" Blowoff Assembly

Detail:                   W-7A



# City of Port Townsend - Public Works Department

## Standard Detail

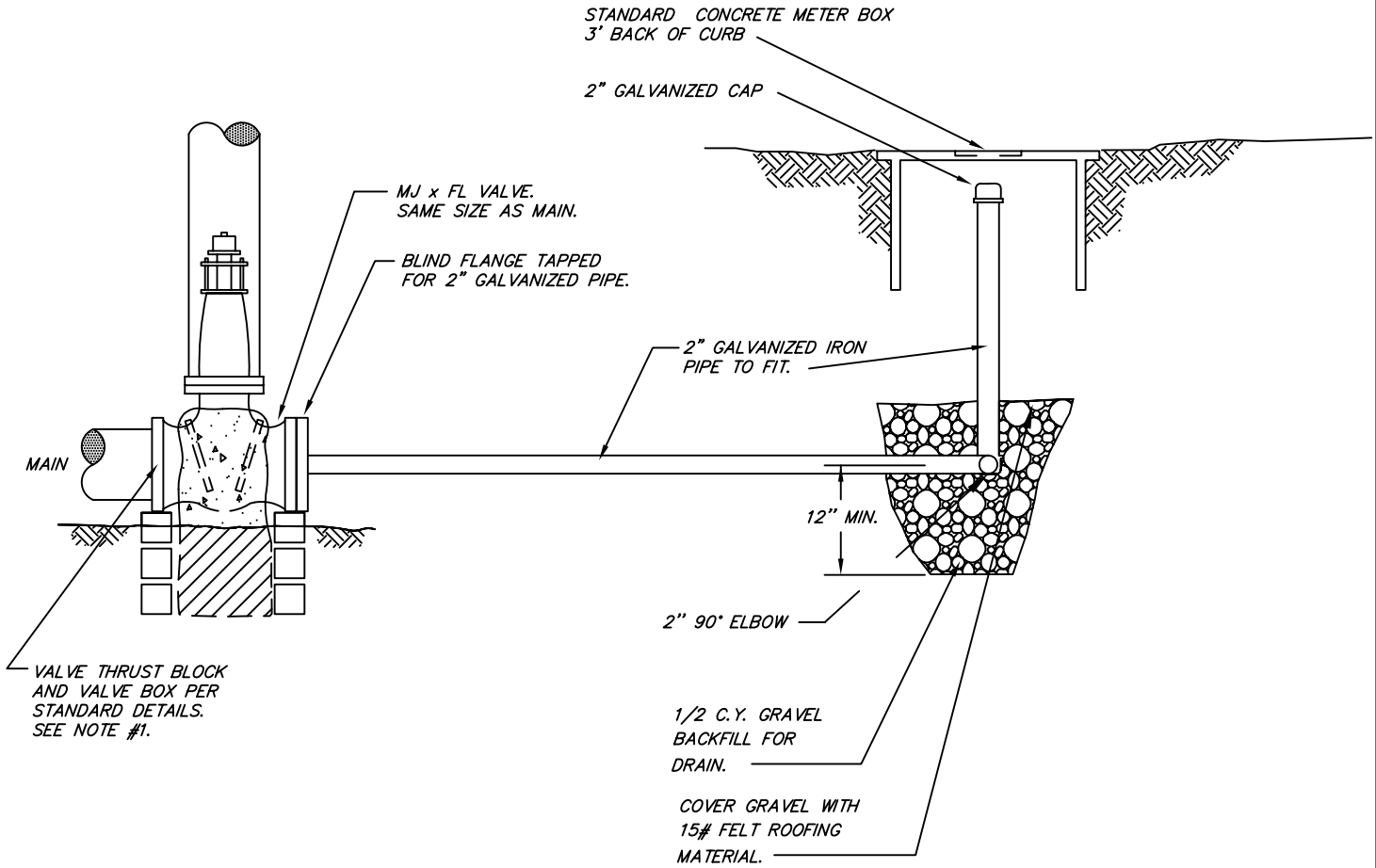

Date: April 1997	No.	Date	Revision	By	Apvd	Temporary 2" Blowoff Assembly
Approved By:						Detail: W-7B
File: E:\eng_std\standard\water						



# City of Port Townsend - Public Works Department

## Standard Detail

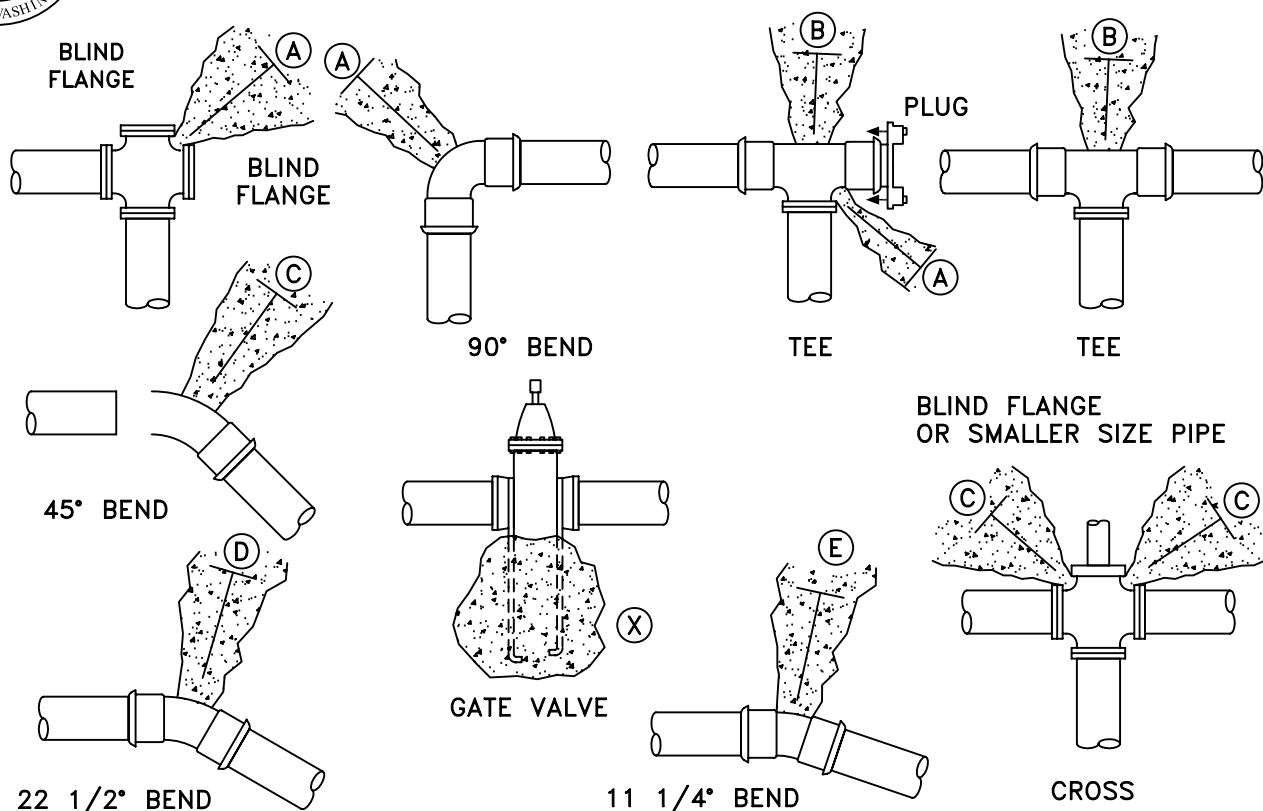

### THRUST BLOCK – TABLE

MIN. BEARING AREA AGAINST UNDISTURBED SOIL  
SQUARE FEET

PIPE SIZE	(A) FT <sup>2</sup>	(B) FT <sup>2</sup>	(C) FT <sup>2</sup>	(D) FT <sup>2</sup>	(E) FT <sup>2</sup>	(X) FT <sup>2</sup>
4"	3	1	1	1	1	NONE
6"	4	4	2	1	1	NONE
8"	7	6	4	2	1	4
10"	11	10	6	3	2	6
12"	16	14	9	5	3	9
14"	22	19	12	6	3	12
16"	29	25	16	8	4	16
18"	36	31	20	10	5	20
20"	45	39	24	13	6	24
22"	54	47	29	15	8	29
24"	64	56	35	18	9	35
28"	87	76	48	24	12	48
30"	101	87	55	28	14	55
36"	175	125	78	40	20	78
42"	197	171	107	55	27	107
48"	257	223	140	71	36	140

### NOTES:

1. BEARING AREA OF CONCRETE THRUST-BLOCK BASED ON 200 PSI PRESSURE AND SAFE SOIL-BEARING LOAD OF 2,000 POUNDS PER SQUARE FOOT.
2. AREAS MUST BE ADJUSTED FOR OTHER PIPE SIZES, PRESSURES, AND SOIL CONDITIONS.
3. CONCRETE BLOCKING (CLASS 3000) SHALL BE CAST IN PLACE AND HAVE A MINIMUM OF 1/4 SQUARE FOOT BEARING AGAINST THE FITTING.
4. BLOCK SHALL BEAR AGAINST FITTINGS ONLY AND SHALL BE CLEAR OF JOINTS TO PERMIT TAKING UP OR DISMANTLING OF JOINT.
5. CONTRACTOR SHALL INSTALL BLOCKING ADEQUATE TO WITHSTAND FULL TEST PRESSURE UNDER ALL CONDITIONS OF SERVICE.
6. MINIMUM ROD DIAMETER SHALL BE 3/4" ASTM A-307 WITH 36KSI YIELD STRENGTH.

Date: April 1997	No.	Date	Revision	By	Apvd	Horizontal Thrust Blocks  Detail:                   W-8
Approved By:						
File: E:\eng_std\standard\water						



# City of Port Townsend - Public Works Department

## Standard Detail

VERTICAL BLOCKING					
PIPE SIZE	VB	CU.FT.	A	D	L
4"	11 1/4"	8	2.0'	3/4"	1.5'
	22 1/2"	11	2.2'		2.0'
	30°	17	2.6'		
6"	11 1/4"	11	2.2'	3/4"	2.0'
	22 1/2"	25	2.9'		
	30°	41	3.5'		
8"	11 1/4"	16	2.5'	3/4"	2.0'
	22 1/2"	47	3.6'		
	30°	70	4.1'		
12"	11 1/4"	32	3.2'	3/4"	2.0'
	22 1/2"	88	4.5'		
	30°	132	5.1'		
16"	11 1/4"	70	4.1'	7/8"	3.0'
	22 1/2"	184	5.7'		
	30°	275	6.5'		
20"	11 1/4"	91	4.5'	7/8"	3.0'
	22 1/2"	225	6.1'		
	30°	330	6.9'		
24"	11 1/4"	128	5.0'	1"	3.5'
	22 1/2"	320	6.8'		
	30°	480	7.9'		
VERTICAL BLOCKING FOR 45° BENDS					
4"	45°	30	3.1'	3/4"	2.0'
6"		68	4.1'		
8"		123	5.0'		
12"		232	6.1'	3/4"	2.5'
16"		478	7.8'	1 1/8"	4.0'
20"		560	8.2'	1 1/4"	
24"		820	9.4'	1 3/8"	4.5'

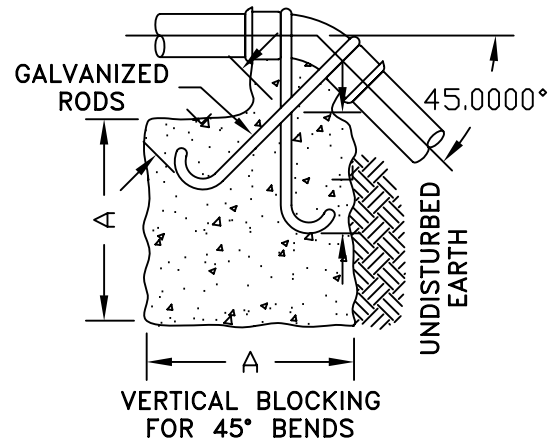
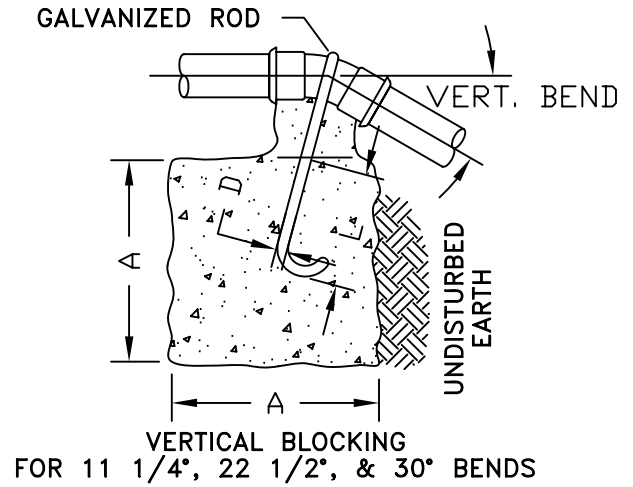

**NOTE:**

CONCRETE BLOCKING BASED  
ON 200 P.S.I. PRESSURE  
& CLASS 3000 CONCRETE

DEAD WEIGHT BLOCKING						
PIPE SIZE IN.	PIPE AREA IN <sup>2</sup>	TYPE OF FITTING				
		22 1/2°	45°	60°	90°	
4	12.5	0.3	0.6	0.7	1.1	
6	28.3	0.5	1.1	1.4	2.1	
8	50.3	0.9	1.9	2.5	3.8	
12	113	2.1	4.2	5.6	8.4	
16	201	3.7	7.5	9.9	15	
18	254	4.9	10	13	20	
20	314	6.0	12	16	24	
24	432	7.9	16	21	32	

SIZE OF DEAD WEIGHT BLOCK, C.Y. CONCRETE

Date: April 1997

Approved By:

File: E:\eng\_std\standard\water

No.	Date	Revision	By	Apvd

Vertical and Dead Weight  
Concrete Blocking

Detail:                      W-9



# City of Port Townsend - Public Works Department

## Standard Detail

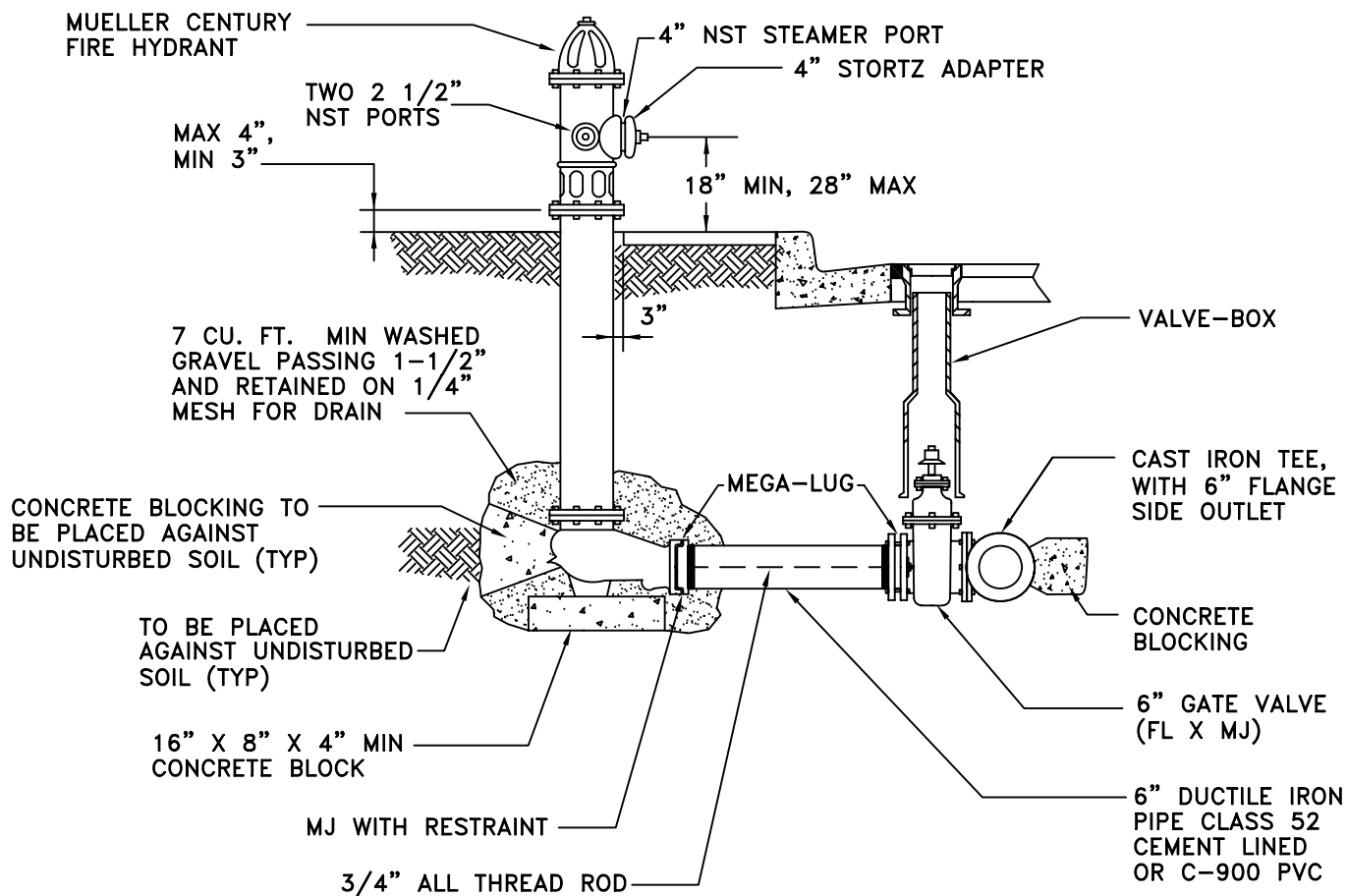

Date: April 1997

No.	Date	Revision	By	Apvd

Approved By:

File: E:\eng\_std\standard\water

Fire Hydrant  
Assembly

Detail: W-10





# City of Port Townsend - Public Works Department

## Standard Detail

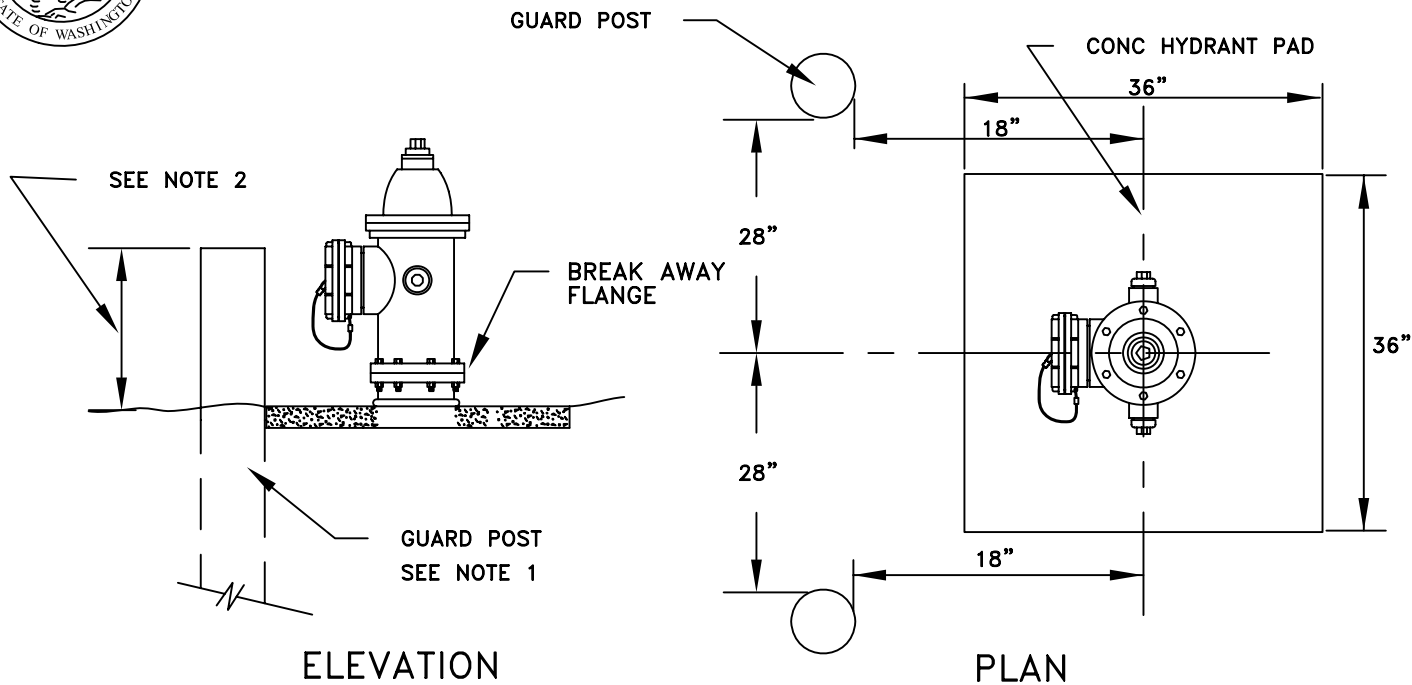

### FIRE HYDRANT GUARD POST

(SEE NOTES 1 AND 2)

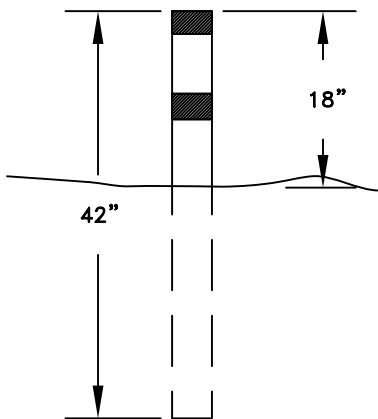

### VALVE MARKER POST

(SEE NOTES 3, 4 AND 5)

### NOTES:

- 1 GUARD POSTS SHALL BE 6' LONG, 8" IN DIAMETER PRECAST CONCRETE OR 6' LONG, 6" DIAM SCH 40, CONCRETE FILLED CLASS 52 STEEL PIPE. PAINTED WITH TWO COATS OF "RUST-O-LEUM" NO. 2766, HI GLOSS YELLOW PAINT.
- 2 TOP OF GUARD POST SHALL BE LEVEL WITH TOP OF FIRE HYDRANT OR 30" IF NOT ON LEVEL GROUND.
- 3 VALVE MARKER POST SHALL BE 42" PORTABLE TRAFFIC DELINEATOR POST W/TWO REFLECTOR STRIPS. THEY SHALL BE FURNISHED NEW AND UNUSED AND BURIED 24" DEEP, TO LEAVE 18" EXPOSED AS A MARKER POST THE LETTER "V" AND THE DISTANCE TO THE VALVE SHALL BE STENCILED ON THE POST WITH 2" HIGH NUMERALS, WITH BLACK ENAMEL PAINT.
- 4 VALVE MARKER POSTS SHALL BE INSTALLED FOR ALL VALVES LOCATED IN UNIMPROVED OR UNPAVED AREAS. VALVE MARKER POSTS SHALL BE SET IN A SAFE AND REASONABLY CONSPICUOUS LOCATION.
- 5 VALVE MARKER POSTS ARE NOT REQUIRED FOR AUXILIARY HYDRANT VALVES.

Date: April 1997

Approved By:

File: E:\eng\_std\standard\water

No.	Date	Revision	By	Apvd

Fire Hydrant Guard Post  
and Valve Marker Post

Detail: W-11



# City of Port Townsend - Public Works Department

## Standard Detail

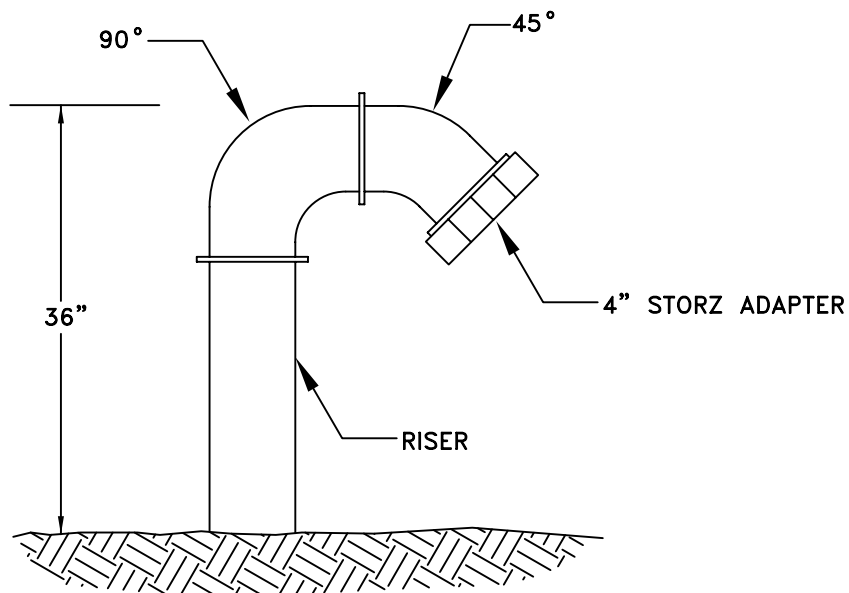
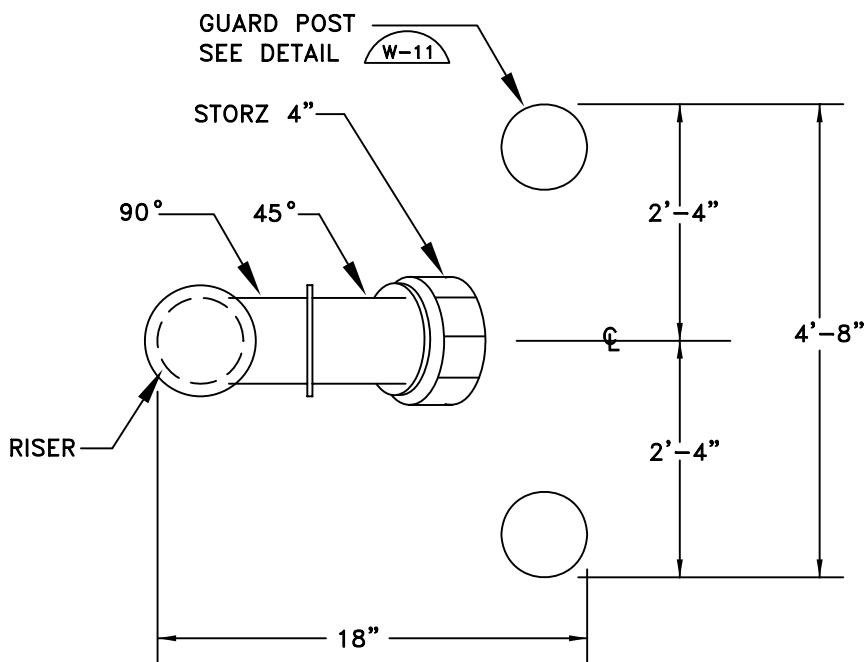

Date: April 1997

Approved By:

File: E:\eng\_std\standard\water

No.	Date	Revision	By	Apvd

Fire Department  
Connection

Detail: W-12