Chapter 3 WASTEWATER

1. General Requirements

- a. Wastewater systems refer to the facilities that transport, treat, and discharge water-carried waste materials from domestic, commercial, and industrial sources. This chapter of the Standards addresses service connections to the existing mains as well as extensions, repairs, lift stations, and other system improvements.
- b. Any extension, replacement, or other improvement of the Port Townsend Wastewater System must be approved by the Department of Public Works and all extensions must conform to the current standards of the City of Port Townsend and to Department of Ecology regulations. The material contained in these Standards shall be used in conjunction with the Washington State Department of Ecology regulations to develop all plans and specification for construction of wastewater facilities. Where there are conflicts or differences between these standards, DOH regulations and city ordinances, the DOH regulations shall apply followed in order of precedence by city ordinances and these Standards.
- c. City sewer service shall not be extended outside the city limits.
- d. In designing and planning for any development, it is the developer's responsibility to see that adequate wastewater systems are provided. The developer must show, in the proposed plans, how the development will be served by sewers and whether the existing system can adequately handle the flows and loads. Improvements necessary to assure that the existing system will not be adversely impacted are the responsibility of the developer. A detailed analysis of the system may be required to evaluate the capacity of the existing hydraulic system to handle the new loads.
- e. Anyone that wishes to extend or connect to the city's wastewater system should contact the Department of Public Works for preliminary information and discussion of the extension proposed. The design of wastewater system improvements is the responsibility of the Developer proposing the construction and upgrading of the public wastewater system.
- f. Prior to acceptance by the city and the discharge of any wastewater, all improvements must be completed and approved, as-builts submitted, all rights-of-way or easements filed, and all applicable fees as set forth in Chapter 3.36 PTMC must be paid.
- g. Issuance of building permits for new construction of single family residences within new subdivisions shall not occur until final Public Works approval of all improvements is given unless otherwise allowed through an approved improvement methods report and/or construction bond. For commercial projects, building permits may be issued upon completion and approval by the Public Works Director of a Wastewater Discharge Plan (including pretreatment when necessary). Certificates of occupancy will not be granted until final Public Works approval and acceptance of all wastewater system improvements is given.
- h. All requests for inspections and for witnessing tests shall be scheduled with the

Public Works Department 24 hours in advance. Failure to give adequate advance notice may result in delays to the contractor for required inspections.

- i. Warranty: The developer shall warranty sewer mains and other wastewater system improvements for one year after installation, approval and acceptance by the City and shall be responsible for one year for any unanticipated settling of excavations or repairs to restored street surfaces. All necessary repairs shall be performed immediately or the city shall perform the repairs at the developer's expense.
- j. Traffic Control: For work in opened streets and rights-of-way, the contractor shall follow procedures described in Chapter 1 of these standards.
- k. Approval for Construction Outside of Business Hours: Any work performed in any street right of way at any time other than Monday through Friday 7 am to 6 pm must have the approval of the Public Works Department.
- l. Noncompliance Penalty: Utility development permits may be revoked from any contractor not complying with these specifications.
- m. Survey: See Chapter 1 of these standards.
- n. Standard Details: All construction shall comply with city Standard Details.

2. Design Standards

- a. The design, construction, and maintenance and operation of wastewater systems shall be in compliance with the city engineering design standards, the sewer code, the wastewater system master plan, the requirements of Jefferson County Environmental Health Department, Washington State Departments of Health and Ecology, any applicable federal regulations, and the WSDOT/APWA Standard Specifications.
- b. The layout and sizing of extensions shall provide for the future continuation of the existing system as determined by the Director. All sewers shall be designed as a gravity sewer whenever physically and/or economically feasible or as outlined in the Wastewater System Master Plan.
- c. The following GENERAL CONDITIONS shall apply to all work on the wastewater system, and, together with those in Chapter 1, Section 2a, shall be included on any plans dealing with the wastewater system construction:
 - i. All work and materials shall conform to the City of Port Townsend Standards and WSDOT/APWA Standard Specifications.
 - ii. The city shall be given 72 hours notice prior to scheduling a diversion of flows in the wastewater system.
 - iii. During the construction of mains and services, the contractor shall cap, plug, or secure the ends of such lines whenever the project is shut down at the end of the day so that contaminants will not enter the lines.
 - iv. All lines shall be tested in conformance with the standard specifications. Prior to final acceptance of all installations, the city reserves the right to conduct an inspection of all main lines by the use of television equipment.
 - v. The city construction inspector shall be notified a minimum of 24 hours in advance of the time that a service connection to an existing main is

-
- needed so that city inspection may be scheduled for the work. The inspector shall be present at the time of the tap.
- vi. Prior to backfilling, all sewer lines and appurtenances shall be inspected and approved by the city's inspector. Approval shall not relieve the contractor for correction of any deficiencies and/or failure as determined by subsequent testing and inspections. It shall be the contractor's responsibility to notify the city for the required inspections.
 - vii. Approximate locations of existing utilities have been obtained from available records and are shown for convenience. The contractor shall be responsible for verification of locations and to avoid damage to any additional utilities not shown. If conflicts with existing utilities arise during construction, the contractor shall notify the public works inspector and any changes required shall be approved by the Public Works Director prior to commencement of related construction on the project.
 - viii. All sewer main extensions within the public right-of-way or in easements must be staked by survey for line and grade prior to starting construction.

3. Sewer Service Connections

- a. All new developments within the city limits are required to connect to the city's sewer system with the following exception:
 - i. New single-family residential development occurring on parcels equal to or greater than one acre in size: a) which is more than 500 feet from the nearest city sewer main, and b) which is not subject to review and threshold determination under the State Environmental Policy Act Implementing Ordinance, Chapter 19.04 PTMC, or c) which is not subject to the permit requirements of the Environmentally Sensitive Areas Ordinance, Chapter 19.05 PTMC.
- b. Managed individual or group on-site septic systems are allowed for new development which meets the requirements of subsection a.i, provided the following conditions are met:
 - i. The soil conditions and parcel size will support the use of an on-site septic system until connection to the city's sewer system;
 - ii. The system is designed to be efficiently converted to the city's sewer system;
 - iii. The developer enters into a no protest agreement with the City (*i.e.*, requiring connection to the city's sewer system within two year(s) of when a sewer main is within 260 feet of the property line, and/or participation in a Local Improvement District ("LID") which may include installation of sewer mains, interceptors, pump stations and/or Latecomer Agreement paybacks), filed on record title, as a condition of any building or development permit; and
 - iv. The septic system is approved by the Jefferson County Environmental Health Department.
- c. Existing parcels containing an on-site septic system are required to connect to the

-
- d. city's sewer system by July 2002.
 - d. After July 2002, any parcel containing an on-site septic system will be required to connect to the city's sewer system unless the nearest sewer main is greater than 260 feet (*i.e.*, one city block measured along public rights-of-way) from the nearest portion of the subject parcel (in which case connection is required within two years of when the sewer is within 260 feet).
 - e. Notwithstanding subsections, c and d above, if an on-site septic system fails connection is required unless the nearest portion of the subject parcel is greater than 500 feet from the nearest sewer main, in which case the septic system may be repaired to serve the subject property.

4. Sewer Main Extensions and other System Improvements

- a. When Required. A main extension, main replacement, pump station, maintenance hole, force main or other system improvement may be required for any of the following reasons to mitigate the direct impacts of the proposed development:
 - i. Whenever a customer requests service and the premises to be served does not abut a sewer main;
 - ii. Whenever the existing sewer main(s) is not adequate to provide the necessary service;
 - iii. Whenever the development cannot be served by a gravity system;
 - iv. Where other components of the sewer system are inadequate to handle the increased wastewater discharges;
 - v. Whenever necessary to handle wastewater from the development; or
 - vi. Whenever necessary to protect public health and safety.
- b. Right-of-way acquisition. When sufficient right-of-way does not exist, the customer shall provide sufficient right-of-way or utility easements where necessary to serve the needs of the development and for the maintenance and orderly growth of the system.

5. Procedural Requirements

- a. Public Works Technical Conference. Anyone wishing to connect to or extend the city's water system is encouraged to request a meeting with Public Works staff to obtain preliminary information of the location of existing facilities and to review water system extension requirements. A technical conference will generally be required for anyone proposing a main extension.
- b. Application for sewer service. Any person seeking to connect to the City's water system shall submit an application to the Public Works Department on forms provided by the city.
 - i. Information required for the sewer service application shall include:
 - (1) The name of the owner or agent and his or her mailing address, the street address or name of the premises to be served, and the legal description of the premises to be served.
 - (2) An estimate of wastewater volumes for all subdivisions, multi-family, mixed use, commercial and manufacturing proposals.

-
- (3) A site plan and details showing the proposed location for the service connection.
 - (4) Upon request by the director, a hydraulic analysis and assessment of the ability of the collection system and treatment facilities to handle the wastewater discharges and proposed mitigations if required.
 - (5) Proposed pretreatment facilities and best management practices for commercial and manufacturing facilities.
 - (6) Any other information deemed reasonably necessary by the director to review the application for compliance with Title 13 PTMC and these Standards or required by other provisions of the City's code, Department of Health requirements, SEPA, permit conditions, or city ordinance.
 - (7) The design drawings and specifications for the water system improvements required under "item d" below.
- ii. Complete Application Required. The city will not process any application unless and until the information required by this section is substantially complete. The public works director may reject an application as incomplete within a reasonable time of review, in which case the director shall return it to the applicant with an indication of the additional information needed to make the application complete.
- c. Utility Development Permit. A Utility Development Permit is required for any sewer main extension, replacement, and other system improvements:
 - i. The Utility Development Permit shall contain all design drawings and information necessary for the Public Works Department to determine compliance with these Standards and the applicable codes and standards incorporated by reference into these Standards.
 - ii. When the City receives the application, the application will first be checked for completeness. Once it is determined to be complete the City will begin its review of the application.
 - iii. Utility Development Permits are reviewed and approved by the Public Works Department. Construction shall not commence until the permit is approved by the Director.
 - d. Construction Drawings and Engineered Plans. All applicants for sewer system connections and improvements shall furnish drawings and specifications necessary to describe and illustrate the proposed sewer system improvements. If base maps prepared by a licensed land surveyor are available, the design and construction plans shall be submitted on such maps. If base maps are unavailable, the public works director may require a survey to avoid conflicts with existing facilities, to determine elevations and contours, and to determine the limits of the right-of-way.
 - i. All plans for sewer main extensions and other sewer system improvements shall be prepared, signed and stamped by a civil engineer licensed in the State of Washington.

- ii. For main extensions and replacements of 260 feet (one city block) or less in Tier 1 which do not require plans under another authority of the PTMC, the developer has the option of the city performing the engineering for the fee identified in Chapter 3.36 PTMC. Alternatively, the developer may pay for his or her own engineering with the full cost to be borne by the developer.
- iii. All design and construction plans and specifications shall be prepared in accordance with current DOT/APWA standard specifications and the city's engineering design standards. If discrepancies exist in the standards and specifications, the city engineering design standards shall take precedence.
- iv. The requirement for engineered plans may be waived in certain instances as defined by the PTMC and approved by the City Engineer for minor improvements to the sewer system that can be adequately inspected and certified by the City Engineer and that will still assure the long-term integrity of the system. As-builts must still be submitted.
- v. All plans must be reviewed and approved by the Director prior to proceeding with construction.
- vi. Plans should be prepared on plan/profile type sheets and show both plan and profile views. Other utilities are to be shown in profile view and in plan view.
- vii. Plans shall include specific city standards for such items as maintenance holes, drop connections, side sewers, etc.
- viii. Plans shall show invert elevations of the main at the outlet and all inlets of each maintenance hole, slope of the main, and surface elevations of the maintenance hole lid. In the profile view, the finish ground elevation over the pipe shall be shown as well as crossings of other existing or proposed utilities. Stationing of side sewers from the downhill maintenance hole is required. Drawings shall show mainline connection depth and distance from nearest maintenance hole, the street that mainline connection is made in and the nearest cross street shall be identified. Drawings will show and label all connections and pipe diameters.
- ix. In all cases where a line is to be placed in an easement, the easement is to be shown with measurement information to accurately lay it out prior to constructing the pipe line.
- e. Inspection: All sewer system installations shall be inspected and approved by the City. It is the responsibility of the developer or contractor to notify the city 24 hours in advance of necessary inspections at the proper point in construction. All excavations must be left open until inspection is complete.
- f. Approval, Acceptance, Conveyance and As-Builts: Certificates of occupancy will not be granted until final Public Works approval and acceptance of all improvements is given easements filed, all applicable fees paid and as-built drawings are received.

6. Gravity Sewer Mains

a. Size

- i. Sewer mains shall be sized for the ultimate development of the tributary area.
- ii. New gravity systems shall be designed on the basis of an average daily per capita flow of not less than 100 gallons per capita per day. The table “Design Basis for Sewage Works” from the DOE Manual is assumed to cover normal infiltration, but additional allowances shall be made where conditions dictate. Generally, laterals and submain sewers should be designed to carry, when running full, not less than 400 gallons daily per capita contributions of sewage. When deviations from these per capita rates are used, a description of the procedure used shall be submitted to the City Engineer for review and approval. Nothing shall preclude the city from requiring the installation of larger mains if the city determines that a larger size is needed to meet requirements for future service. The developer may be eligible for a Utility Latecomer Agreement.
- iii. The minimum pipe size for sanitary sewer mains shall be 8 inches in diameter, except that a 6-inch sewer may be approved in limited instances where the sewer has no potential to be extended to serve future customers.
- iv. The minimum size service connection lateral in the street right-of-way shall be 6 inches and the minimum size for a service lateral on private property shall be 4 inches in accordance with the Standard Details. The depth at the property line shall be 5 feet, except as approved by the City Engineer. Sewer connections to the main shall be made with a wye connection. All new main connections to existing mains shall require the installation of a new maintenance hole if not made at an existing maintenance hole.
- v. All nonferrous pipe shall be installed with metal wire and tracer tape as shown on the Standard Details and described in Chapter 1.
- vi. Gravity sewer mains shall typically have a depth of 5 feet. Actual depth will be determined by the slope, flow, velocity, and elevation of the existing system as proposed by the applicant and approved by the City.

b. Slope

- i. All sewers shall be designed and constructed to give mean velocities, when flowing full, of not less than 2.0 feet per second, based on Mannings’ formula using an “n” value of 0.013. The following are minimum slopes which should be provided; however slopes greater than these are desirable.
 - (1) 8-inch Mains: 0.40 feet per 100 feet.
 - (2) 10-inch Mains: 0.28 feet per 100 feet.
 - (3) 12-inch Mains: 0.22 feet per 100 feet.
 - (4) 15-inch mains: 0.15 feet per 100 feet.
 - (5) 18-inch mains: 0.12 feet per 100 feet.
 - (6) 21-inch mains: 0.10 feet per 100 feet.

- (7) 24-inch mains: 0.08 feet per 100 feet.
- (8) 30-inch mains: 0.06 feet per 100 feet.
- (9) 36-inch mains: 0.05 feet per 100 feet.
- ii. Under special conditions, slopes slightly less than those required for the 2.0 feet per second velocity requirement may be permitted by the City Engineer upon request by the applicant with engineering documentation.
- iii. Sewers shall be laid with a uniform slope between maintenance holes.
- iv. Sewers with slopes greater than 6.0 percent slope, or where groundwater may travel as a conduit, may require check dams. Such dams shall be noted on the drawings.
- v. Sewer mains on slopes of 20% or greater shall be securely anchored per WSDOT/APWA standards.
- c. Materials: Materials for sanitary sewer pipe shall meet the requirements of the following:
 - i. Sanitary Sewer Pipe - Preferred:
 - (1) PVC Ringtight ASTM D3034, SDR 35 or ASTM F789 with joints and gaskets conforming to ASTM D3212 and ASTM F477.
 - (2) Ductile Iron Pipe shall conform to ANSI A 21.51 or AWWA C151 and shall be cement mortar lined with push-on joint or mechanical joint. The ductile iron pipe shall be Class 52, unless otherwise approved.
 - ii. Sanitary Sewer Pipe - For repair only:
 - (1) Concrete Sewer Pipe shall meet the requirements of ASTM C14 Class 3, unless otherwise approved.
 - (2) Reinforced Concrete Sewer Pipe shall conform to ASTM Designation C76 and shall be of the class specified on the plans.
 - iii. Pipe Zone Material - see drawings
- d. Connections to Existing System
 - i. All new sewer connections to the existing system shall be physically plugged until all tests have been completed and the city approves the removal of the plug.
 - ii. Connection of the new sewer mains to existing maintenance holes shall be core drilled for connection by the contractor. The base shall be rechanneled so as to provide smooth transitions into existing flows.
 - iii. Connection of a new sewer onto an existing sewer main where a maintenance hole is not available shall be accomplished by pouring a concrete base and setting maintenance hole sections around the existing pipe. For extending onto the end of a pipe, a precast base may be used.
 - iv. Straight grades between the invert out of the new maintenance hole and the invert out of the existing maintenance are preferred over drops.
 - v. An outside drop connection shall be constructed per the Drawings for a sewer entering a maintenance hole whenever the elevation of the entering sewer is 24 inches or more above the maintenance hole invert. Where the difference is less than 24 inches a fillet shall be poured below the entering

-
- pipe to prevent solids deposition.
- vi. Connections when a building sewer is the same size as the existing sewer main shall be accomplished by installation of a new maintenance hole, unless otherwise approved in writing by the City.
 - e. Taps: Taps shall be a gasketed saddle wye or wye with a couplet. Taps shall not protrude into the existing sewer main. All taps shall be by the contractor. The contractor shall notify the city inspector at least 24 hours prior to the tap. All tap installation shall be witnessed by the city inspector.
 - f. Location: Parallel water and sewer lines shall be laid at least 10 feet apart horizontally. If this is impractical, the water line shall be at least three (3) feet above the top of the sewer line. Wherever it is necessary for sewer and water lines to cross each other, the crossings shall be made at an angle of approximately 90 degrees, and the sewer shall be located three or more feet below the water line if possible. See Chapter 2 “Water and Sewer Main Separation” for additional requirements.
 - g. Installation
 - i. General
 - (1) Installation of gravity mains shall be per WSDOT/APWA Standard Specifications Section 7-17 and 7-08.3.
 - (2) For typical trench details see Standard Details.
 - (3) Excavations shall be kept free of water.
 - (4) Safety is the responsibility of the contractor. Contractor(s) must conform to WISHA standards when working in excavations.
 - (5) All crossings and patches of city streets will be made to City standards and the contractor will be held responsible for the integrity of the patch for one full year.
 - (6) All new sewer services will be equipped with backflow preventer(s) when required by the City because of the floor elevation of the house relative to the sewer, or due to sewer main surcharging.
 - ii. Pipe Bedding and Pipe Zone
 - (1) The pipe bed shall be prepared per WSDOT/APWA 7-08.3(1)C.
 - (2) Pipe bedding and pipe zone material shall be per the WSDOT/APWA Standard Specifications Section 9-03.9(3).
 - (3) Bedding and pipe zones shall be as shown on the Standard Drawings.
 - (4) Bedding and pipe zone material shall be placed in more than one lift. The first lift, to provide at least 4 inches thickness under the pipe, shall be placed before the pipe is installed and shall be spread and compacted so that the pipe is uniformly supported. Subsequent lifts of not more than 6 inches thickness shall be installed to the crown of the pipe. A further 12 inch lift of moderately compacted material shall be placed over the crown of the pipe prior to the start of backfilling the trench.

-
- (5) Compact all pipe zone and bedding material to 95% density as determined by ASTM D698.
 - iii. Backfill
 - (1) Backfill material shall be per WSDOT/APWA 7-08(3) and as shown on the standard Drawings
 - (2) Backfill shall be compacted to 95% density under roadways and traveled ways. Controlled density backfill may be proposed as an alternate for road cuts. Compaction to 90% may be allowed where no roadways, driveways or vehicular travel will occur.
 - (3) Backfill to the elevation necessary to apply required surface treatment
 - iv. Surface Treatment
 - (1) Repair surface to original condition, including all driveways, culverts, curbs, gutters, sidewalks or other facilities damaged by the construction
 - (2) Street repair shall be per Chapter 6.
 - (3) Any drainage ditches damaged or disturbed during construction shall be pulled, dug, or otherwise repaired to restore storm drainage flow.
 - (4) Any disturbed vegetation shall be restored.
 - h. Laying the Sewer Pipe
 - i. Per WSDOT/APWA 7-083(2).
 - ii. All sewer main installations shall have line and grade stakes or hubs set prior to construction.
 - iii. The contractor may use any method such as “swede line and batter board” and “laser beam” etc., which would allow him to accurately transfer the control points provided by the surveyor in laying the pipe to the designated alignment and grade.
 - iv. When using the “swede line and batter board” method, the contractor shall transfer line and grade into the ditch where they shall be carried by means of a taut grade line supported on firmly set batter boards at intervals of not more than 30 feet. Not less than three batter boards shall be in use at one location. Grades shall be constantly checked and in event the batter boards do not line up, the work shall be immediately stopped and the cause remedied before proceeding with the work.
 - v. When using a “laser beam” to set pipe alignment and grade, the contractor shall constantly check the position of laser beam from surface hubs provided by the surveyor to ensure the laser beam is still on alignment and grade. In the event the laser beam is found out of position, the contractor shall stop work and make necessary corrections to the laser beam equipment and pipe installed.
 - i. Inspections
 - i. Pipe and connections shall remain exposed until inspected by the City.
 - ii. The contractor or his/her representative will be on-site at the time of the

- inspection.
- j. Plugs and Connections
 - i. All fittings shall be capped or plugged with a plug of an approved material gasketed with the same gasket material as the pipe unit; or shall be fitted with an approved mechanical stopper; or shall have an integrally cast knock-out plug. The plug shall be able to withstand all test pressures without leaking, and when later removed, shall permit continuation of piping with jointing similar to joints in the installed line.
 - k. Jointing
 - i. Where it is necessary to break out or connect to an existing sewer during construction, only new pipe having the same inside diameter will be used in reconnecting the sewer. Where joints must be made between pipes with a mismatched wall thickness, the contractor shall use flexible gasketed coupling adaptor to make a watertight joint. Couplings shall be those manufactured by “Romac,” “Smith Blair,” or approved equal for reinforced pipes and “Fernco” or approved equal for non-reinforced pipes.
 - l. Cleaning and Testing
 - i. All sanitary sewer pipe installations shall be cleaned and tested in accordance with WSDOT/APWA Standard Specifications Section 7-17.3(2). A copy of this testing procedure is included at the end of this Section. Sewers and appurtenances shall be cleaned and tested after backfilling by either the exfiltration or low pressure air method at the option of the contractor, except where the groundwater table is such that the Public Works Director may require the infiltration test.

7. Alignment Tolerance

- a. The maximum deviation from established line and grade shall not be greater than 1/32 inch per inch of pipe diameter and not to exceed 1/2 inch per pipe length.
- b. No adverse grade in any pipe length will be permitted.
- c. The difference in deviation from established line and grade between two successive joints shall not exceed 1/3 of the amounts specified above.

8. Maintenance holes

Maintenance holes shall be installed in accordance with these Standards, the Standard Details and WSDOT/APWA Standard Specifications Section 7-05. Where conflicts occur, these Standards shall have precedence over WSDOT/APWA Standard Specifications Section 7-05.

- a. Materials:
 - i. Precast maintenance holes shall meet the requirements of ASTM C478 with either a precast base or a cast-in-place base made from 3,000 psi minimum structural concrete. Maintenance holes shall be as shown on the Standard Details and WSDOT drawing B-23a. Any deviations from the Standard Details will be subject to review of a shop drawing submitted by the contractor and approved by the Public Works Director.

-
- ii. The minimum diameter of maintenance holes shall be 48 inches; larger diameters are preferable for large diameter sewers.
 - iii. Joints between maintenance hole elements shall be rubber gasketed conforming to ASTM C443.
 - iv. All pre-cast concrete shall be Class 4000. Maintenance hole channels shall be Class 3000 concrete. Concrete blocks or concrete (masonry) rings may be used for adjustment of the casting to final street grade.
 - v. Standard precast cones shall provide eccentric reduction from 48 inches to 24 inches with height of not less than 18 inches and 54 to 24 inches with height of not less than 24 inches. The eccentric cone shall be offset so as not to be located in the tire track or a traveled lane and shall be in line with the steps.
 - vi. Maintenance hole frames and covers shall be cast iron conforming to the requirements of ASTM A536, Grade 80-55-06, Olympic foundry Type MH 30D/T, or approved equal. The minimum clear opening in the frame shall be 24 inches. Grade rings and covers shall be machine-finished or ground-on seating surfaces so as to assure non-rocking fit in any position. The public works director may require that maintenance holes located in areas subject to inflow shall be equipped with a PRECO sewer guard watertight insert, or approved equal. All casting shall be coated with bituminous coating prior to delivery to the job site.
 - vii. Safety steps shall be fabricated of polypropylene conforming to ASTM D-4101, injection molded around a 1/2 inch ASTM A-615 grade steel bar with anti-slip tread. Steps shall project uniformly from the inside of the wall. Steps shall be installed per WSDOT/APWA Standard Plan B-24a.
- b. Spacing and location:
- i. Maintenance holes shall be provided at a maximum spacing of 300 feet. Intervals at distances greater than 300 feet require the approval of the Public Works Director.
 - ii. Maintenance holes shall be provided at intersections, and at all changes in direction, grade or pipe size.
 - iii. All maintenance holes are to be accessible to maintenance vehicles.
 - iv. Maintenance holes are not allowed in a fill section unless base is on a cut section.
 - v. A maintenance hole is required at the ends of all sewer mains, unless approved by the City.
- c. Construction Requirements:
- i. Bedding: Unless otherwise directed by the Public Works Director, maintenance holes shall be constructed with pre-cast base sections or cast-in-place to grade upon a 6 inch minimum depth of Crushed Surfacing Base Course meeting the requirements of WSDOT/APWA Standard Specifications Section 9.03.9(3). [verify ref.] The Crushed Surfacing Base Course shall be compacted to 95% maximum density.
 - ii. Joints: Shop drawings of the joint design shall be submitted to the Public

Works Director for approval, prior to manufacture. Completed joints shall show no visible leakage and shall conform to the dimensional requirements of ASTM 478. Joints shall be grouted from the inside.

- iii. Lift holes: Shall be grouted from the outside and the inside of the maintenance hole.
- iv. Maintenance hole channels: All maintenance holes shall be channeled unless otherwise approved in writing by the Public Works Director. Maintenance hole channels shall be made to conform accurately to the sewer grade and shall be brought together smoothly with well rounded junctions. Channel sides shall be carried up vertically to the crown elevation of the various pipes, and the concrete shelf between channels shall be smoothly finished and warped evenly with slope to drain.
- v. Maintenance hole pipe connections:
 - (1) All pipes except PVC pipe entering or leaving the maintenance hole shall be provided with flexible joints within 1/2 of a pipe diameter or 12 inches, whichever is greater, from the outside face of the maintenance hole structure and shall be placed on firmly compacted bedding, particularly within the area of the maintenance hole excavation which normally is deeper than that of the sewer trench. Special care shall be taken to see that the openings through which pipes enter the maintenance hole are completely and firmly rammed full of non-shrink grout to ensure water tightness.
 - (2) PVC pipe connected to maintenance holes shall be provided with a maintenance hole adaptor complete with gasket and approved by the Public Works Director. No pipe joint in PVC shall be placed within 10 feet of the outside face of the maintenance hole.
- vi. Connections to existing maintenance holes:
 - (1) The contractor shall verify invert elevations prior to construction. The crown elevation of laterals shall be the same as the crown elevation of the incoming pipe unless specified. The existing base shall be reshaped to provide a channel equivalent to that specified for a new maintenance hole.
 - (2) The maintenance hole shall be kept in operation at all times and the necessary precautions shall be taken to prevent debris or other material from entering the sewer, including a tight pipeline bypass through the exiting channel if required.
 - (3) The contractor shall core drill, line drill or wall saw an opening to match the size of pipe to be inserted. Where line drilling is the method used, the drilled holes must be interconnected. Line drilling shall be accomplished by the use of a small core drill or a rotary hammer. Jackhammer shall not be used. All openings must provide a minimum of 1 inch and a maximum of 2 inches clearance around the circumference of the pipe. Upstream pipes, except PVC pipe, penetrating the walls of maintenance holes shall

be placed with the bell facing out such that the bell is placed snug against the outside wall of the structure as the angle of penetration allows. Pipe, except PVC pipe, leaving or entering maintenance holes shall be provided with a flexible joint within 1/2 of a pipe diameter, or 12 inches, whichever is greater. After pipes have been placed to their final position, they shall be grouted tight with non-shrink grout in a workmanlike manner. PVC pipe connecting to existing maintenance hole shall be installed using gasketed inserts as approved by the Director.

- (4) The contractor shall comply with all safety requirements for confined space entry.

9. Service Connection, Side Sewer, Building Sewer

A service connection for sewer (including the side sewer and building sewer) refers to the extension from the building plumbing at a point two feet from the outside of the outside of the outer foundation wall of the structure to the public sewer main. The service connection within the public right-of-way is considered the side sewer; the building sewer connects from the building to the side sewer.

a. General

- i. Prior to construction a side sewer permit must be obtained from the City. During the permit process the City may request additional information about the type and amount of flows anticipated to the sewer system.
- ii. Drawings for side sewers shall be required on forms provided by the city during the permit process. Information to be supplied is specified on the form. If the service connection does not involve extension of a main, design of the side sewer by a licensed engineer is not required.
- iii. A separate and independent side sewer shall be constructed for every premises, except where multiple connections are approved by the Public Works Director.
- iv. All side sewer service connections shall gravity flow into the City's wastewater system unless otherwise approved.
- v. The construction of sewer service connections and side sewers shall conform to the latest edition of the Uniform Plumbing Code, WSDOT/APWA 7-18, and to the other Sections of these Standards. Where inconsistencies exist, these Standards for side sewers shall apply alike to all side sewers on public rights-of-way and private property.
- vi. Maintenance of the sewer service connection is the sole responsibility of the owner of the premises served.
- vii. Side sewer locations shown on the drawings shall be subject to relocation in the field after construction starts.
- viii. If a side sewer is to serve two houses a six-inch clean out extending to within 12 inches of the ground surface will be required at the wye where the upper-grade connections are made.
- ix. Side sewers are not permitted to cross a public right-of-way or run parallel

to the right-of-way centerline. All lots must front on a public sanitary system in order to be served.

- x. If a building sewer is to serve more than one property, by joint agreement of the owners, an approved document insuring that all properties involved shall have perpetual use of the side sewer, and having provisions for maintenance and for access for repair purposes, shall be signed by the recorded owner. This document shall be notarized and recorded with the county auditor and shall be referred to as an “easement.”

b. Size

- i. The minimum size for side sewers in the public right-of-way is 6-inches in diameter.
- ii. The minimum size for a single family residential building sewer shall be 4-inch diameter.
- iii. The minimum size of a dual residential, commercial/industrial and multi-family building sewer is 6-inches in diameter. A larger size may be required as determined by projected wastewater flows from the service.

c. Slope

- i. The minimum slope on side sewers and building sewers shall be 2 percent.

d. Installation

- i. Installation of service lines shall be the same as Water Main - Installation above.
- ii. No side sewer connection shall be made to the public sewer until that section of sewer main has been approved by the city for side sewer connections.
- iii. Connections to mainline will be sanitary tee or wye; 45 and 22 degree wyes may also be used depending on the situation. Connection to mainline will be either saddled, strapped and gasketed or installed with rubber repair coupler with stainless bands. Cutting in a ringtight sanitary tee or wye is also an option. No glue joints are allowed. No 90 degree bends are allowed. All right angle bends will be made with a combination of two 45 degree bends.
- iv. In the event that there is no suitable tee or stub out, a tap to the main may be made by a licensed contractor, under the direct supervision of the Public Works Director. The tap shall be made with the approved rubber joint saddles on all types of sewer main. Grouting in a tee or wye is not permitted. Great care shall be taken in cutting a neat hole into the sewer main, and in the event of breakage of the sewer main, the broken section shall be removed and replaced at no cost to the city. [Alternate to iii]
- v. The contractor shall prevent entrance of all foreign material into the pipe.
- vi. The type of joint to be used for connecting the side sewer pipe to the tee or stub out shall be that for which the wye was designed. Rubber or plastic joint adapters shall be used as required to connect pipes and wyes of different materials or joint designs. Selected bedding material shall be hand-tamped in a moist condition under and around the wye and

connection to the wye made so as to prevent any pressure on the wye. Care shall be taken to prevent the dislodging of this hand-tamped material during the balance of the backfill and water settling operation.

- vii. A cleanout shall be provided within three (3) feet of the building or structure served. The cleanout shall be a wye from the service line with a branch installed upward. The wye connection shall be of the same size as the service run. A vertical riser shall be installed in the wye. This riser shall be brought to within 12 inches of the finish grade and capped with an approved cast iron plug or plastic plug with metal for detection. The plug shall be machined to fit the standard joint of the pipe being used, with the standard gasket.
 - viii. The connection to the building sewer shall be suitable rubber gasket sleeve or adapter. Grout joints will not be allowed. In exceptional cases, the Public Works Director may allow a connection using a hot pour jointing material JC 60 or approved equal.
 - ix. Where any property served by a side sewer carries industrial waste, the owner or occupant shall install a control maintenance hole in the side sewer to facilitate observation, sampling and measurement of the wastes when the same may be required by the Public Works Director. Such maintenance hole shall be accessibly and safely located and shall require plans approved prior to installation by the Public Works Director, and shall be maintained and installed by the owner or occupant at his/her sole expense.
- e. Excavation, Bedding, Backfill and Compaction:
- i. Follow procedures for sewer mains
 - ii. It shall be the responsibility of the licensed contractor to cut the road surface, dig a trench, lay the pipe, make the connection to the sewer or wye and backfill the trench within the limits of any public thoroughfare or right-of-way.
 - iii. The contractor shall restore all roadways, drainage features, culverts, and all other disturbed features to their original condition or as shown on the drawings.
 - iv. The contractor shall prevent any damage to the sewer main, tee or stub out, and shall so conduct his/her trenching operations as to prevent the possibility of damage occurring. Undercutting of sewer main and wye is prohibited.
 - v. The bottom of the trench must be smooth and free of large rocks which may injure the side sewer pipe. Where unsuitable bedding is found, as determined by the Public Works Director, the contractor shall over-excavate and prepare a bedding.
 - vi. Minimum cover for side sewers shall be five feet in the right-of-way unless otherwise approved.
- f. Special discharge situations:
- i. In any case where the house or building drain is too low to permit gravity

- flow to the public sewer, the same may be lifted by an individually-owned pumping facility that discharges to the side sewer or the sanitary sewer.
- ii. A backwater valve may be prescribed by the Public Works Director where elevations of the sewer require it.
 - (1) The effective operation of any backwater valve shall be the responsibility of the owner of the side sewer.
 - g. Pipe Materials: the following pipe may be used between the sewer main and the property line and shall be used between the property line and the building drain:
 - i. Preferred: PVC
 - ii. Other: Cast Iron, Concrete Pipe
 - iii. The concrete pipe shall be rubber gasket pipe using "Tylox," "Flex-Tite," "Press Seal" or other approved units. The cast iron pipe shall have mechanical joints or "o" ring rubber gasket joints Tylon or equal.
 - h. Testing:
 - i. All side sewers shall be tested before backfill but after piping is suitably anchored. Side sewers that are reconstructed or repaired to a length of 10 feet or more shall be tested for water tightness. Testing of newly reconstructed sections of side sewers consisting of a single length of pipe will not be required. Testing shall be performed in the presence of the City Inspector in accordance with WSDOT Standard Specifications. A copy of this testing procedure is included at the end of this Section.
 - ii. When a new side sewer is installed, the entire length of new pipe shall be tested. In cases where a new tap is made on the main, the first joint of pipe off the main shall be installed with a test tee, so that an inflatable rubber ball can be inserted for sealing off the side sewer installation for testing. In cases where the side sewer stub is existing to the property line, the test ball may be inserted through the clean-out wye to test the new portion of the side sewer installation.

10. Grease Traps

Grease traps shall be required for all restaurants and other food processing facilities. Grease traps shall be cleaned at least once per year. All maintenance and cleaning costs are the responsibility of the property owner/operator.

11. Pump Stations

Any pump station which is intended to be conveyed to the City for operation and maintenance shall meet the following requirements.

- a. Pump Station (General): Pump stations must be designed and installed to take into account pressure and hydraulics of distribution system, safety and aesthetics.
- b. Noise Control: The following shall be provided for noise abatement and control:
 - i. All pump stations will be provided with adequate noise control to meet state noise guidelines.
 - ii. Pumps shall be housed in a concrete or equivalent structure with sound attenuation provided.

- iii. Pump stations shall be located away from residences where feasible.
- c. Plans: The plans for lift stations shall include the following:
 - i. An overall site drawing of the lift station showing the location of all components including elevations;
 - ii. Service size, voltage and enclosure type and location in relation to the pump station;
 - iii. A list of specific materials used including quantity description and manufacturer names;
 - iv. A schematic and line diagram of the service and motor control center and lift station;
 - v. All applicable telemetry installation with schematics;
- d. Operations and Maintenance Manual: Three sets of the Operation and Maintenance manual from the lift station manufacturer shall be supplied.
- e. Design Report: A design report shall be submitted with each lift station demonstrating its conformance with the standards and shall address the following items:
 - i. Pump Data: size and type, horsepower, pump curves, head capacity, velocity
 - ii. Motor: size and type, cycle length, type of motor
 - iii. Controls: type
 - iv. Telemetry: alarm system compatible with City system
 - v. Housing: size and type, ventilation, humidity control, interior lighting, access
 - vi. Well sizing: type, storage capacity
 - vii. Maintenance: warranty, tools and equipment required
 - viii. Electrical Service: size and type, source
 - ix. Corrosion Protection: type of materials, coatings, linings, maintenance
 - x. Site Layout: location of lift station on property
 - xi. Testing: operational, pressure
 - xii. Piping and Valves: size and type
- f. Pumps are to be engineered and manufactured under a written Quality Assurance program. The Quality Assurance program is to be in effect for at least five (5) years, to include a written record of periodic internal and external audits to confirm compliance with UL Quality Assurance specifications.
- g. Lift stations must be either a wet well/dry well type or submersible type.
- h. Location:
 - i. Lift station structures and electrical and mechanical equipment shall be protected from the 100 year flood.
 - ii. Lift stations shall be readily accessible by maintenance vehicles during all weather conditions. The facility should be located off the traffic way of streets and alleys.
- i. Emergency Power:
 - i. Lift stations must be provided with an emergency power source or auxiliary pumping equipment to ensure continuous operability unless

experience has shown the frequency and duration of outage to be low and the lift station and/or sewers provide storage sufficient for expected interruptions in power service.

- ii. Provision of an emergency power supply may be accomplished by connection of the station to at least two independent public utility sources, or by provision of portable or in-place internal combustion engine equipment that will generate electrical or mechanical energy, or by the provision of portable pumping equipment.
- iii. Emergency power shall be provided that, alone or combined with storage, will prevent overflows from occurring during any power outage that is equal to the maximum outage in the immediate area during the last 10 years. If available data are less than 10 years, an evaluation of a similar area served by the power utility for 10 years would be appropriate.
- iv. In-Place Equipment:
Where in-place internal combustion equipment is utilized, the following will apply:
 - (1) The unit shall be bolted in place. Facilities shall be provided for unit removal for purposes of major repair or routine maintenance.
 - (2) Provision shall be made for automatic and manual startup and cut-in.
 - (3) Unit size shall be adequate to provide power for lighting and ventilating systems and such further systems that affect capability and safety as well as the pumps.
 - (4) The unit internal combustion engine should be located above grade, with suitable and adequate ventilation of exhaust gases.
 - (5) If diesel fuel is used there shall be a containment area for 125% of the diesel fuel tank capacity.
- v. Portable Equipment:
Where portable equipment is utilized, the following apply:
 - (1) Pumping units shall have the capability to operate between the wet well and the discharge side of the station and the station shall be provided with permanent fixtures that will facilitate rapid and easy connection of lines.
 - (2) Electrical energy generating units should be protected against burnout when normal utility services are restored, and should have sufficient capacity to provide power for lighting and ventilating systems and any other station systems affecting capability and safety, in addition to the pumping units.
- vi. Storage:
Where storage is provided in lieu of an emergency power supply, wet well and tributary main capacity above the high-level alarm should be sufficient to hold the peak flow expected during the maximum power outage duration during the last 10 years.

j. Telemetry:

A telemetry system shall be installed at the lift station which shall be connected to and compatible with the existing city alarm system for transferring alarm conditions from the lift station to the central alarm monitor.

k. Automated Controls:

A comprehensive automation system for the lift station shall be supplied. The equipment provided shall be a completely integrated control system consisting of the required power equipment (motor starters, circuit breakers, etc.), automation and monitoring equipment in a factory wired and tested assembly. The submersible level transducer and solid-state controller shall be standard catalogued products of the system supplier to assure one source responsibility, proper system interconnections and reliable, long term operation. The city will accept a Bulletin A1000/D152/F100 Control system as manufactured by Consolidated Electric Company, or equal. Float switches shall not be used.

l. Pump Features:

- i. The following Submersible pumps are acceptable: Flight, Gorman-Rupp, Fairbanks & Morse, or equal.
- ii. Heavy duty, nonclog submersible capable of passing a minimum of 3" spheres.
- iii. Oil-filled, double mechanical shaft seals.
- iv. Integral over temperature and moisture protection.
- v. Rail mounted; stainless steel Schedule 40 pipe.
- vi. Pump Sizing: Minimum two pumps. Sized to handle peak flow with one pump out of service.
- vii. Pump Accessories: All accessories shall be constructed of Type 304 stainless steel.
- viii. Pump safety chain: Able to lift pumps from wet well. Three-eight inch (3/8") diameter 18" stainless steel chain, then stainless steel cable to top of rail. Safety chain clip; eye bolt for safety chain (304 SST)
- ix. Intermediate guide bar bracket: Provide if guide bar exceeds 20' in length
- x. Lifting lugs: Provide if equipment exceeds 70 lbs.
- xi. Anchor bolts: 316 stainless steel, at least 1" diameter
- xii. Pump Installation: Pumps shall be automatically connected to the discharge connection elbow when lowered into place.
- xiii. Spare Parts / Special Tools: Supply the following: 1 set special tools, 1 set upper and lower seal assembly per pump, 1 wear ring per pump, 1 complete O-ring set per pump, 1 set upper and lower bearings, 1 mechanical set seals.
- xiv. Pump Painting
 - (1) Preparation: Abrasive Blast or centrifugal wheel blast (SP 5)
 - (2) Paint Material: Polyamide, anti-corrosive, epoxy primer.
 - (3) Min. Coats, cover: 1 coat, 2.5 MDFT

m. Instrumentation and Control: Provide heavy-duty waterproof control and power

cable, motor temperature sensors for thermal overload detection. Stainless steel control panels required.

- n. Special Construction: Equipment suitable for Class I, Division I, Group C and D hazardous location.

12. Individual Sewage Disposal Systems

The type, capacities, location and layout of a private sewage system shall comply with all Department of Public Health of the State of Washington, or other state regulatory agency, and to the regulations of the city. No septic tank or cesspool shall be permitted to discharge to any public sewer or natural outlet or to the ground surface. The owner shall operate and maintain the private sewage disposal facilities in a sanitary manner at all times at no expense to the city. All private septic tanks shall be thoroughly pumped a minimum of one time during any three-year period.

CHAPTER 3 - APPENDIX

Exhibit #	Standard Detail #	Title
1	SS- 1A	Single Sewer Service
2	SS - 1B	Dual Sewer Service
3	SS - 1C	Deep Trench Service Connection
4	SS - 2A	Trench Section Trenching Pavement Restoration
5	SS - 2B	Pipe Bedding
6	SS - 3	Standard Maintenance Hole/New Maintenance Hole on Existing Sewer
7	SS - 4	Sewer Cleanout Detail
8	SS - 5	24" Maintenance Hole Frame and Lid
9	SS - 6	Drop Connection for Sanitary Sewer
10	SS - 7	Pavement and Installation Underground Maintenance Hole
11	SS - 8	Typical Sewer Connection to Existing Sewer Mains
12	SS - 9	Pipe Anchor Detail For Slopes Greater Than 20%
13	SS - 10	Check Valve Assembly for Joint Use Side Sewer
14	SS - 11	Polypropylene Ladder and Maintenance Step
15		Cleaning and Testing (3 Pages)



City of Port Townsend - Public Works Department

Standard Detail

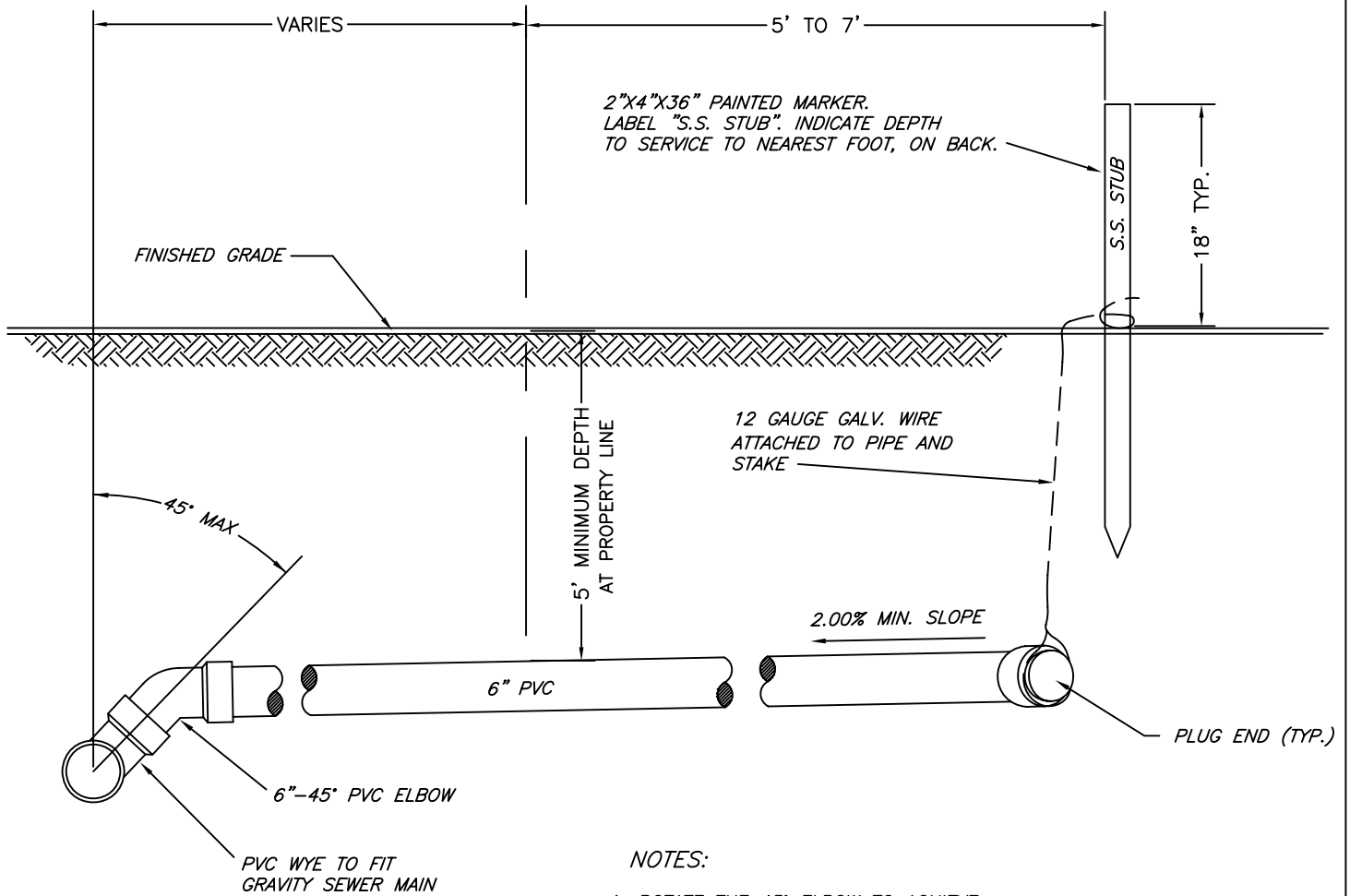

- NOTES:**
1. ROTATE THE 45° ELBOW TO ACHIEVE THE PROPER ANGLE TO REACH THE PROPERTY LINE WITH 5' OF COVER; THE MINIMUM ALLOWABLE SLOPE IS 2%.
 2. 3' MINIMUM TO ADJOINING LOT LINE
 3. SERVICE TO SINGLE RESIDENCE MAY BE REDUCED TO 4" BEYOND PLUG.

ALL WORK AND MATERIALS TO BE IN ACCORDANCE WITH CURRENT STANDARD SPECIFICATIONS FOR ROAD, BRIDGE AND MUNICIPAL CONSTRUCTION, WASHINGTON STATE DEPARTMENT OF TRANSPORTATION, AMERICAN PUBLIC WORKS ASSOCIATION.

Date: April 1997	No.	Date	Revision	By	Apvd	<h3 style="margin: 0;">Single Sewer Service</h3> <p style="font-size: 24px; margin: 10px 0 0 0;">Detail: SS-1A</p>
Approved By:						
File: E:\eng_std\standard\san_sew						



City of Port Townsend - Public Works Department

Standard Detail

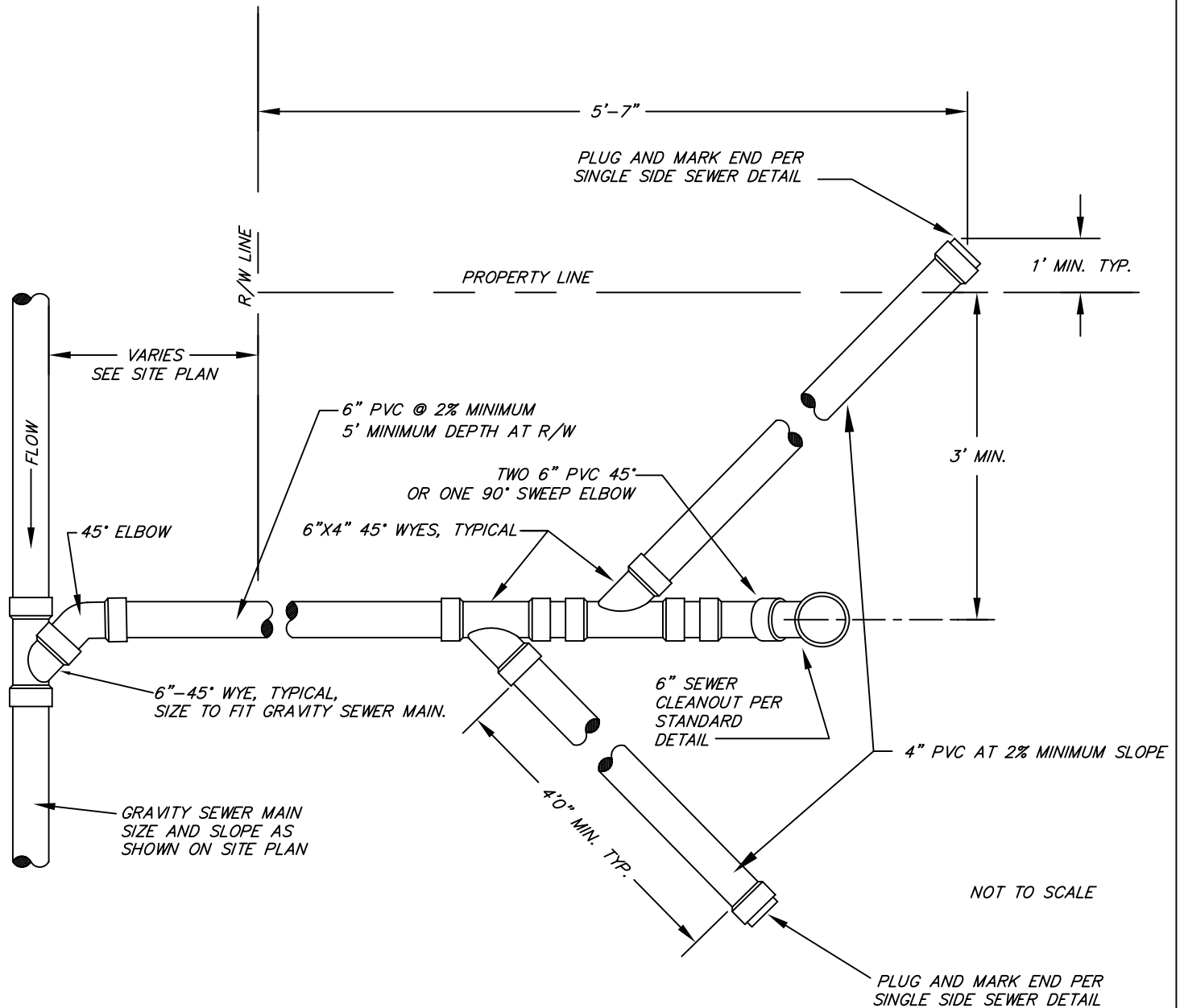

ALL WORK AND MATERIALS TO BE IN ACCORDANCE WITH CURRENT STANDARD SPECIFICATIONS FOR ROAD, BRIDGE AND MUNICIPAL CONSTRUCTION, WASHINGTON STATE DEPARTMENT OF TRANSPORTATION, AMERICAN PUBLIC WORKS ASSOCIATION.

Date: April 1997	No.	Date	Revision	By	Apvd	Dual Sewer Service
Approved By:						
File: E:\eng_std\standard\san_sew						Detail: SS-1B



City of Port Townsend - Public Works Department

Standard Detail

NO 90° OR CONSECUTIVE BENDS

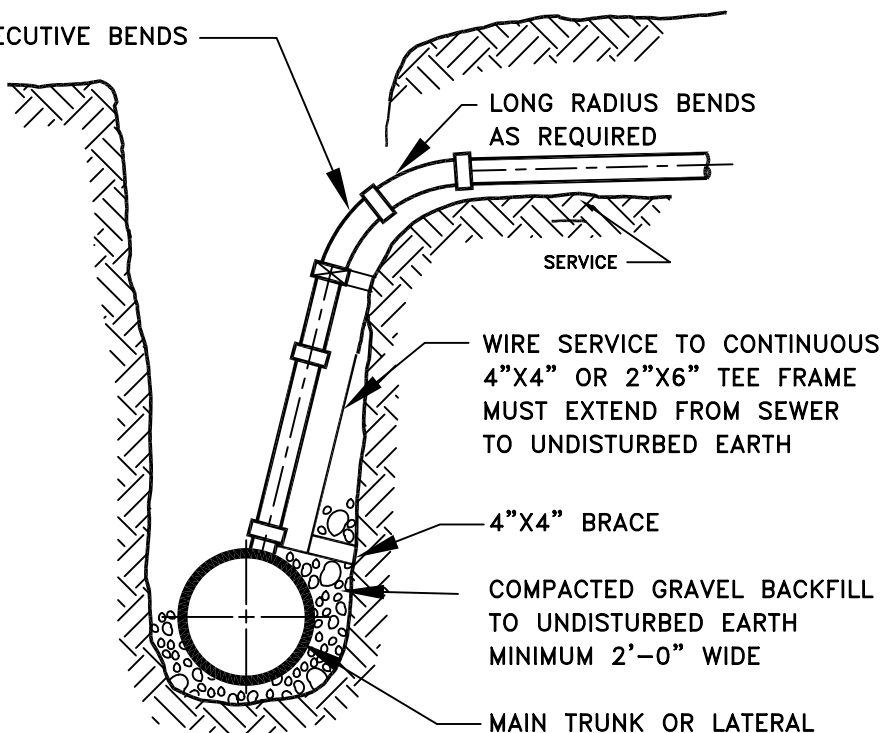

INSPECTION REQUIRED UPON COMPLETION OF ROUGH GRADING AND DURING PLACEMENT OF STRUCTURAL SECTION.

CALL FOR FORM INSPECTION BY CITY PRIOR TO POURING CONCRETE AND PRIOR TO PAVING.

NOTE:

WOOD SUPPORT TO BE USED IN ALL CASES WHERE SERVICE CONNECTION CANNOT BE SUPPORTED FOR FULL LENGTH ON COMPACTED GRAVEL OR WHERE SEWER IS OVER 12'-0" DEEP TO FLOW LINE

ALL WORK AND MATERIALS TO BE IN ACCORDANCE WITH CURRENT STANDARD SPECIFICATIONS FOR ROAD, BRIDGE AND MUNICIPAL CONSTRUCTION*, WASHINGTON STATE DEPARTMENT OF TRANSPORTATION, AMERICAN PUBLIC WORKS ASSOCIATION.

Date: April 1997	No.	Date	Revision	By	Apvd	<h3 style="margin: 0;">Deep Trench Service Connection</h3> <p style="margin: 20px 0 0 0;">Detail: SS-1C</p>
Approved By:						
File: E:\eng_std\standard\san_sew						



City of Port Townsend - Public Works Department

Standard Detail

TRENCH SECTION

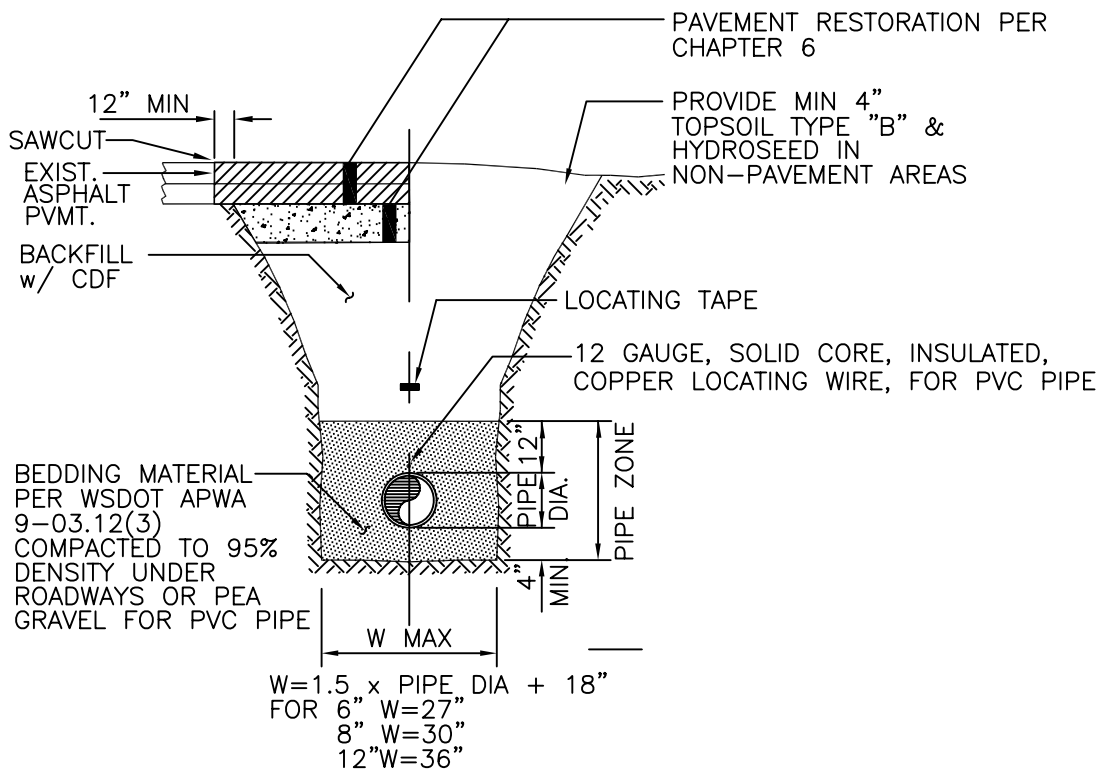

PEA GRAVEL SHALL BE FREE FROM ORGANIC MATTER MEET:
 U.S. STD. SEIVE SIZE %PASSING

3/4"	100
3/8"	95-100
#8	0-10
#200	0-3

Date: April 1997

Approved By:

File: E:\eng_std\standard\san_sew

No.	Date	Revision	By	Apvd

**Trench Section
and Pavement Restoration**

Detail: **SS-2A**



City of Port Townsend - Public Works Department

Standard Detail

SAWCUT EXIST. PAVEMENT
TACK COAT EDGE
MATCH EXIST.
TYP. BOTH SIDES

PAVEMENT RESTORATION
SEE CHAPTER 6.

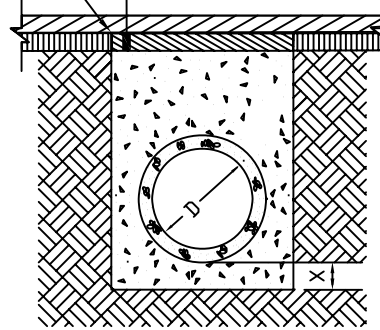

LEGEND

- C.D.F. (CONTROLLED DENSITY FILL) 1/4" MAX. SIZE AGGREGATE
- SLECTED NATIVE SOIL (S.N.S.)
MAX 3/4" DIA. ROCK FOR PVC PIPE
MAX 2" DIA. ROCK FOR CONC.
DI OR CI PIPE

NOTES :

C.D.F. SPEC. PER YARD		
MATERIAL	POUNDS	ABS-VOLUME
CEMENT TYPE I	30	0.15
FLY ASH	300	2.19
SAND (SP.GR 2.68)	2550	15.25
WATER	300 (36 GAL)	4.81
AIR %	18.00	4.86

X = 2" FOR PIPE 6" & UNDER, 3" FOR PIPE 8" TO 18", 4" FOR PIPE 24" OR LARGER

C.D.F. PIPE BEDDING

Date: April 1997	No.	Date	Revision	By	Apvd	Pipe Bedding
Approved By:						
File: E:\eng_std\standard\san_sew						Detail: SS-2B



City of Port Townsend - Public Works Department

Standard Detail

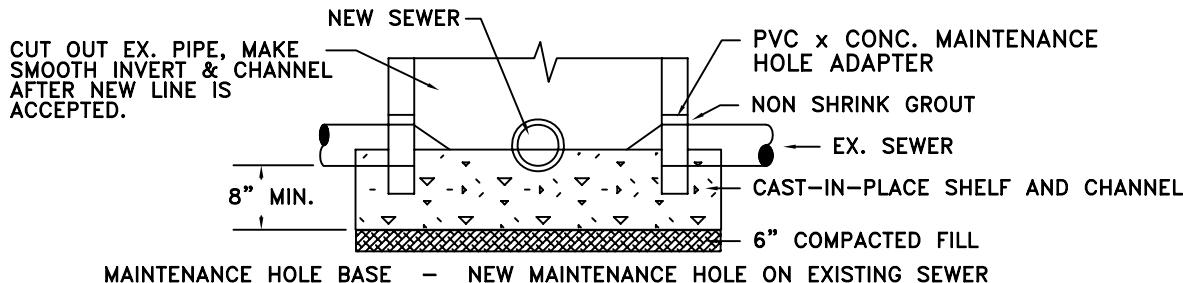
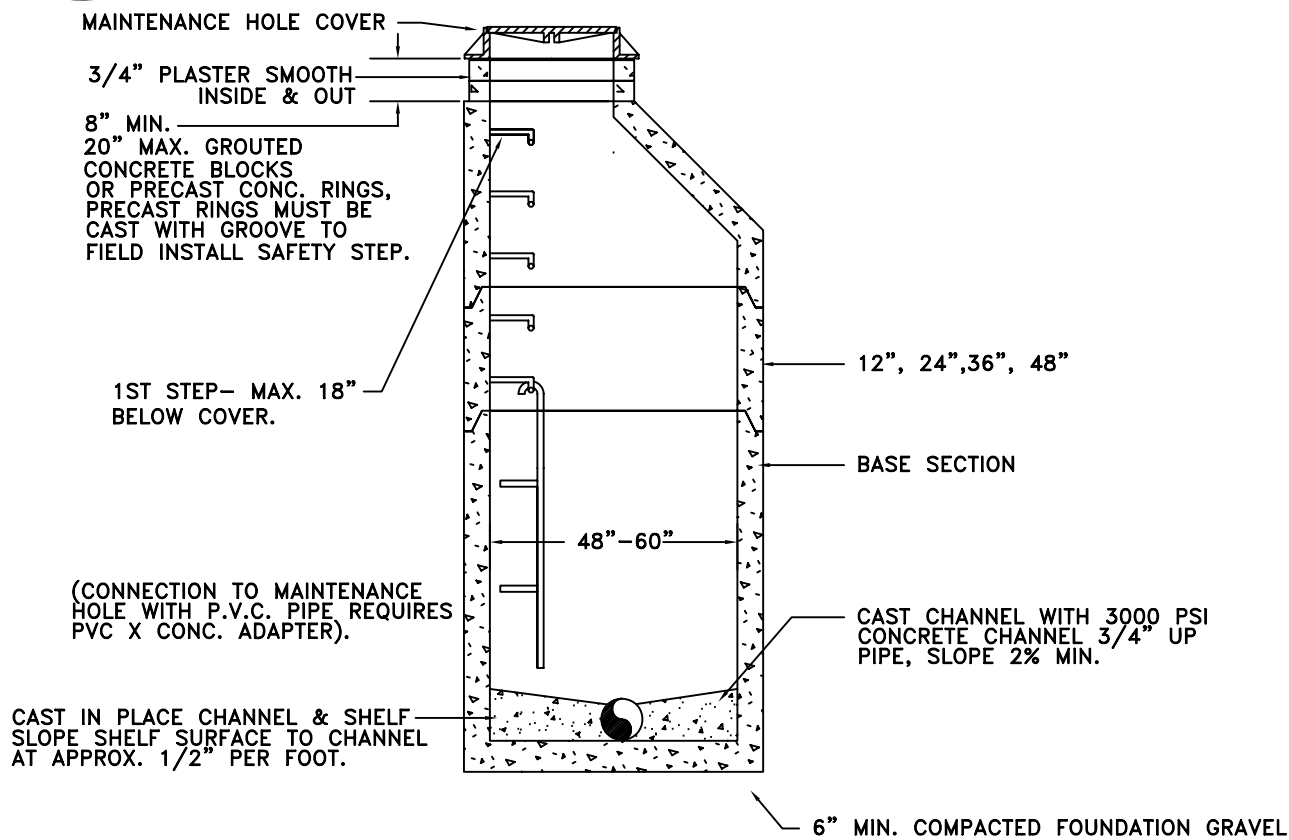

GENERAL NOTES (APPLY TO ALL MAINTENANCE HOLES)

1. PRECAST SECTIONS SHALL BE REINFORCED PER ASTM SPECS FOR CORRESPONDING SEWER PIPE.
2. POLYPROPYLENE SAFETY STEPS WITH 12.0" SEPARATION BETWEEN RUNGS.
3. STEPS IN PRECAST BASE SECTION MAY BE CAST IN PLACE OR MOVABLE SAFETY LADDER GROUTED IN PLACE.
4. ALL HOLES FOR PIPE SHALL BE BLOCKED OUT AT THE TIME OF CASTING OF THE SECTION.
5. ALL RUBBER GASKETED MAINTENANCE HOLES SHALL BE FURNISHED WITH RUBBER GASKET JOINT CONFORMING TO ASTM C443.
6. MAINTENANCE HOLES OVER 10' HIGH SHALL BE FURNISHED WITH 5" MIN. WALL.
7. MINIMUM 3% SLOPE ACROSS MAINTENANCE HOLE CAHNNEL.
8. MAINTENANCE HOLES TO BE WATER TIGHT INCLUDING EXTENSIONS TO COVER CASTING

Date: April 1997	No.	Date	Revision	By	Apvd	Standard Maintenance Hole/New Maint. Hole on Existing Sewer Detail: SS-3
Approved By:						
File: E:\eng_std\standard\san_sew						



City of Port Townsend - Public Works Department

Standard Detail

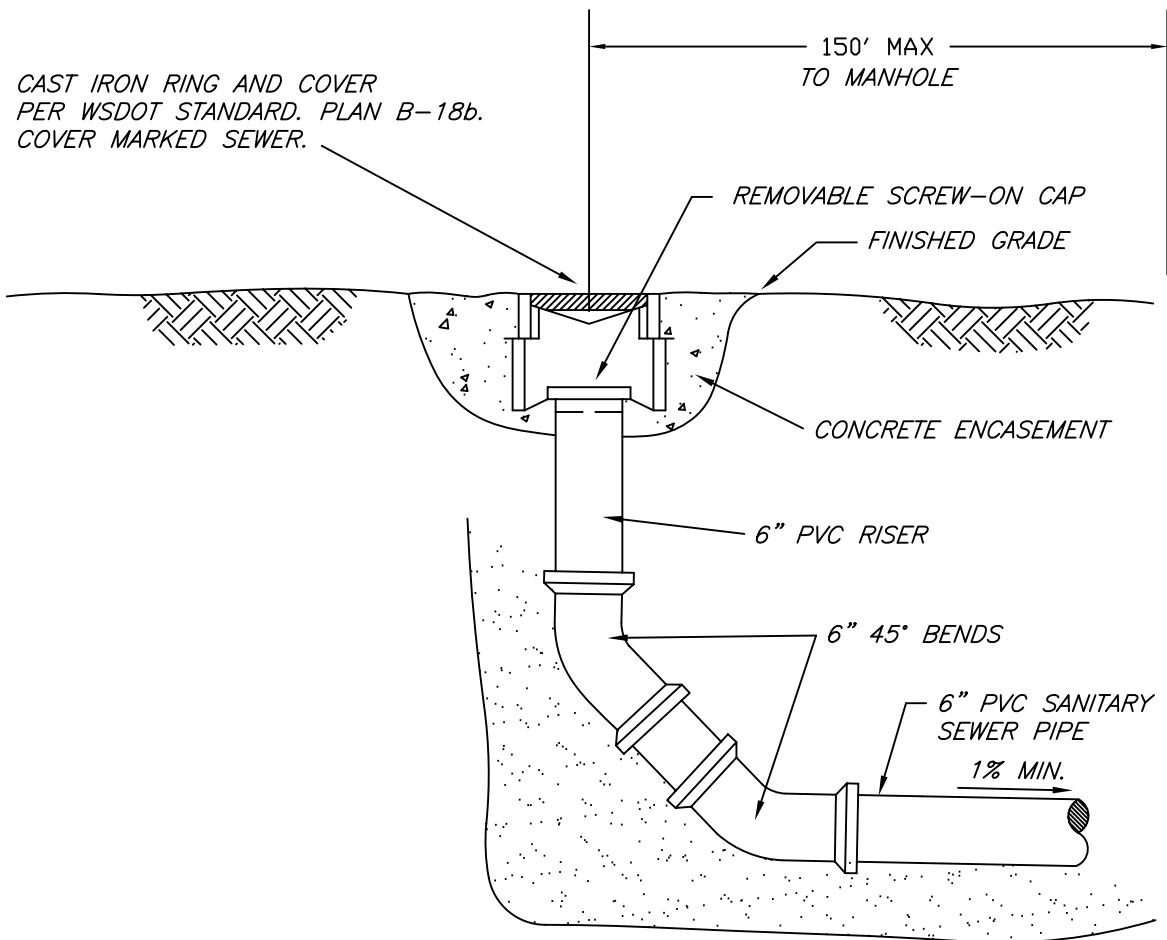

NOT TO SCALE

CALL FOR FORM INSPECTION BY CITY PRIOR TO POURING CONCRETE.

ALL WORK AND MATERIALS TO BE IN ACCORDANCE WITH CURRENT STANDARD SPECIFICATIONS FOR ROAD, BRIDGE AND MUNICIPAL CONSTRUCTION, WASHINGTON STATE DEPARTMENT OF TRANSPORTATION, AMERICAN PUBLIC WORKS ASSOCIATION.

Date: April 1997	No.	Date	Revision	By	Apvd	<h3 style="margin: 0;">Sewer Cleanout Detail</h3>
Approved By:						
File: E:\eng_std\standard\san_sew						



City of Port Townsend - Public Works Department

Standard Detail

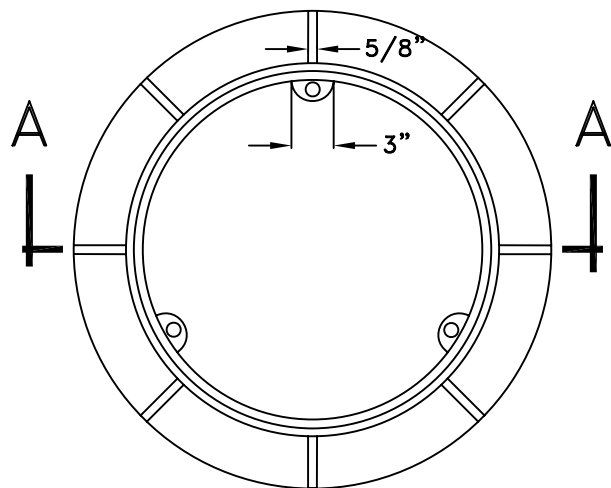

PLAN
MH RING

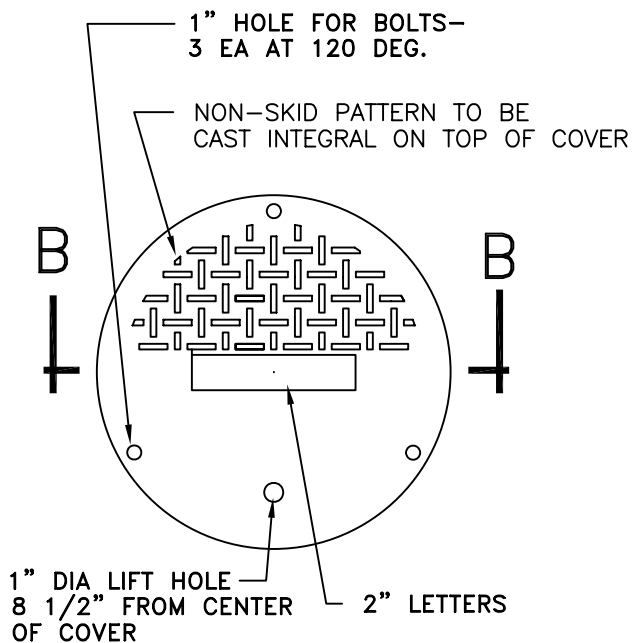

PLAN
MH COVER

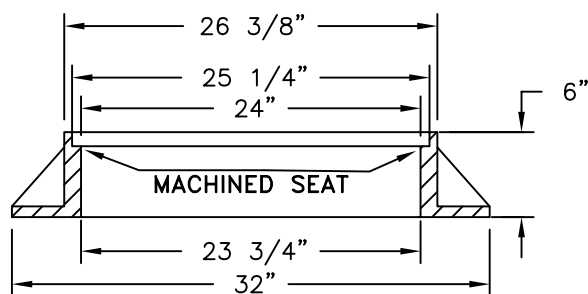

SECTION A-A

DUCTILE OR CAST IRON FRAME
MINIMUM WEIGHT 210 LBS

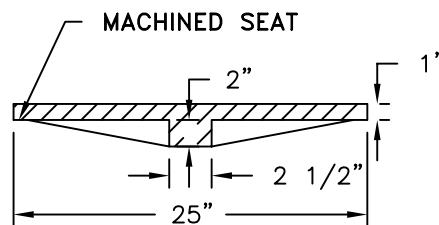

SECTION B-B

DUCTILE OR CAST IRON NON-LOCKING OR
LOCKING COVER, MINIMUM WEIGHT 150 LBS

NOTES:

1. 3 LOCKING BOLT LUGS TO BE PROVIDED FOR EACH MAINTENANCE HOLE
2. COVER SHALL HAVE THE WORD "SEWER" IN 2" RAISED LETTERS.

Date: April 1997	No.	Date	Revision	By	Apvd	<h3 style="margin: 0;">24" Maintenance Hole Frame and Lid</h3> <p style="margin: 0;">Detail: SS-5</p>
Approved By:						
File: E:\eng_std\standard\san_sew						



City of Port Townsend - Public Works Department

Standard Detail

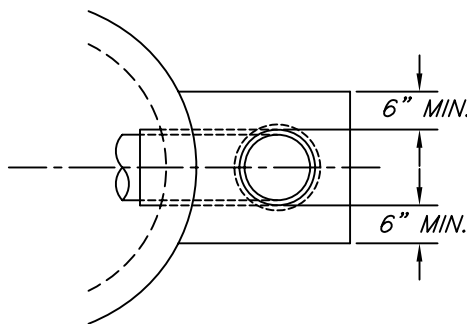

ALL PIPE EXCEPT DUCTILE IRON PIPE SHALL BE CONCRETE ENCASED

ONE LENGTH OF D.I. PIPE (CLASS 50) TO SOLID BEARING WHEN SPAN IS MORE THAN 4'.

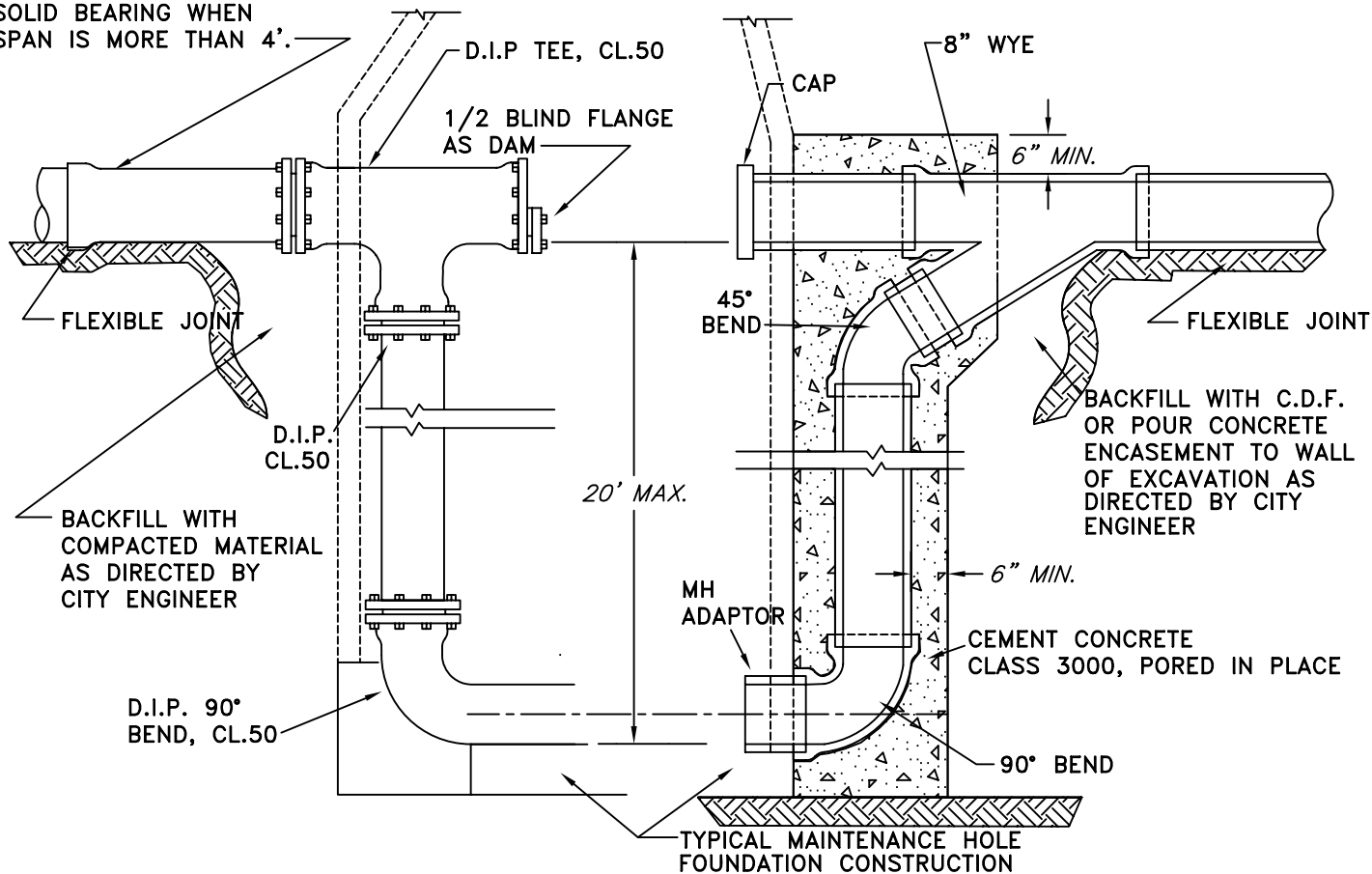

DUCTILE IRON INSIDE
DROP CONNECTION

CONCRETE ENCASED PVC OUTSIDE
DROP CONNECTION

NOTE: EXCAVATION TO BE CONDUCTED PER WISHA GUIDELINES

CALL FOR FORM INSPECTION BY CITY PRIOR TO POURING CONCRETE.

Date: April 1997	No.	Date	Revision	By	Apvd	<h3>Drop Connection For Sanitary Sewer</h3> <p>Detail: SS-6</p>
Approved By:						
File: E:\eng_std\standard\san_sew						



City of Port Townsend - Public Works Department

Standard Detail

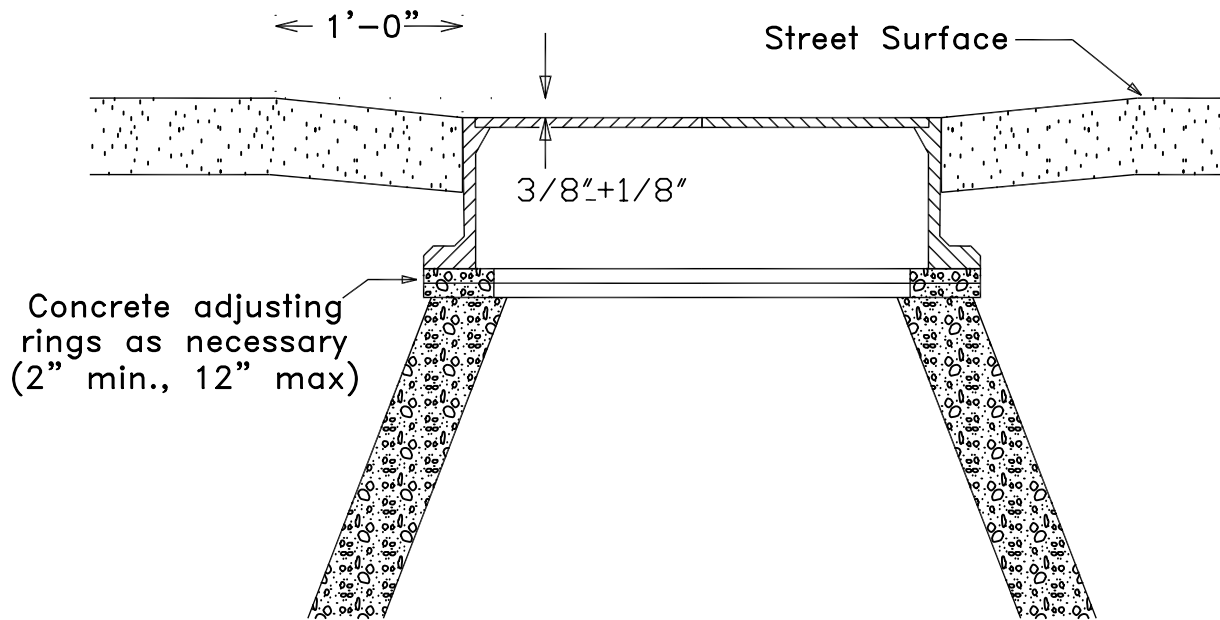

NOTES:

- 1.) Adjust manholes upward with adjusting rings under frame.
- 2.) Adjust maintenance holes downward by removing cone and barrel sections as necessary and replacing with sections of length required to match grade.
- 3.) Slope maint. hole frame as req'd to match slope of street.
- 4.) Final maint. hole adjustments shall be made before paving.

Date: April 1997

Approved By:

File: E:\eng_std\standard\san_sew

No.	Date	Revision	By	Apvd

Pavement and Intallation
Underground Maintenance Hole

Detail: SS-7



City of Port Townsend - Public Works Department

Standard Detail

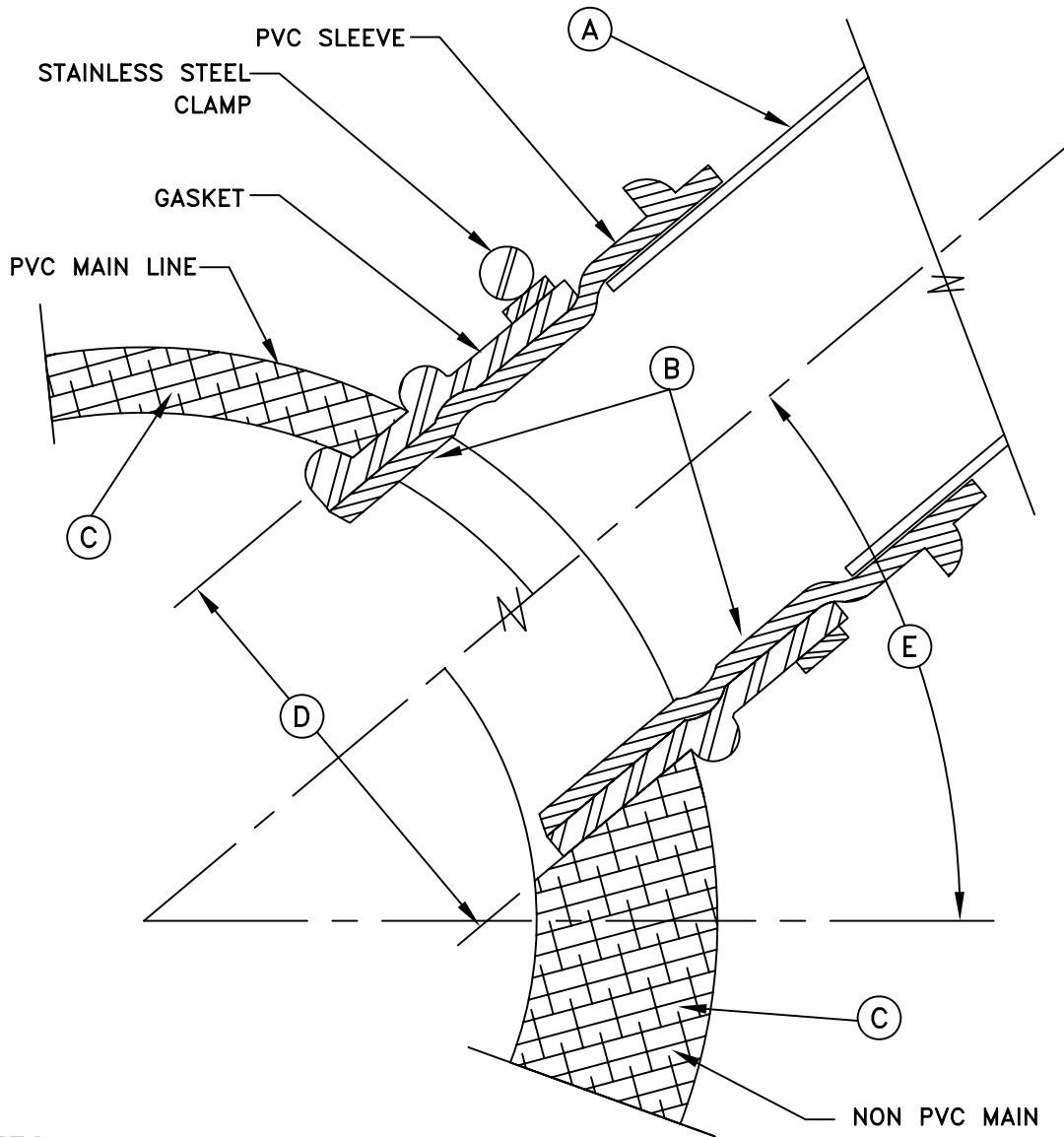

NOTES

- (A) PVC SIDE SEWER. FOR REMAINDER OF PVC SERVICE SEE DWG WW-1.
- (B) FOWLER MFG, CO. "INSERTA TEE" OR APPROVED EQUAL.
- (C) EXISTING SANITARY SEWER MAIN.
- (D) CORE DRILL EXISTING MAINLINE PIPE PER MFG'S SPECIFICATIONS.
- (E) 35° MIN, 45° MAX

Date: April 1997

Approved By:

File: E:\eng_std\standard\san_sew

No.	Date	Revision	By	Apvd

Typical Sewer Connection to
Existing Sewer Mains

Detail: SS-8

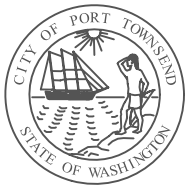

City of Port Townsend - Public Works Department

Standard Detail

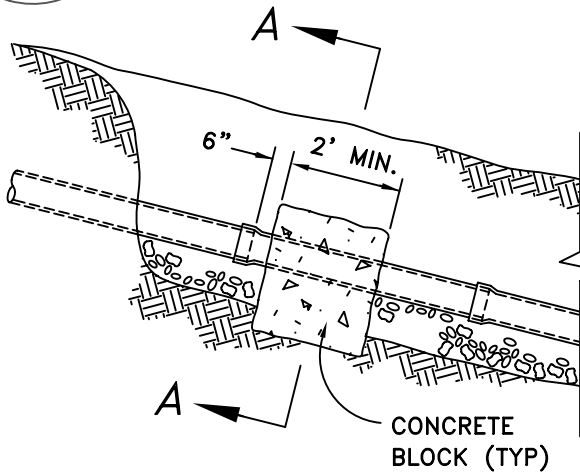

CONCRETE BLOCK ANCHOR

N.T.S.
1 ANCHOR PER JOINT OF PIPE

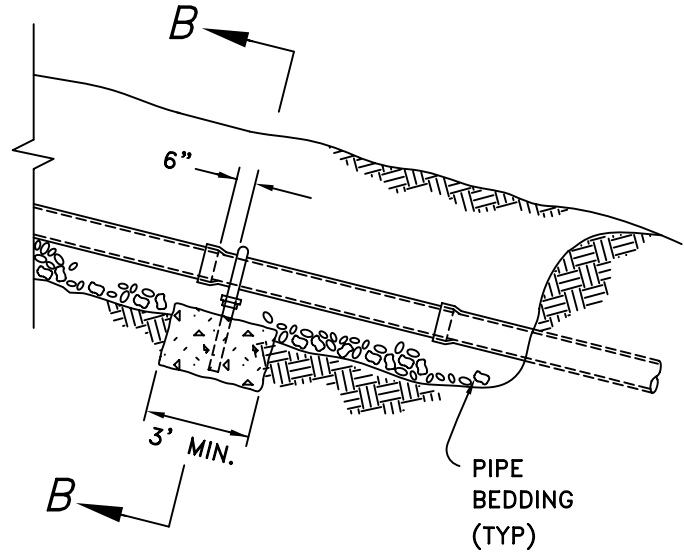

STRAP - FOOTING ANCHOR

N.T.S.
1 ANCHOR PER JOINT OF PIPE

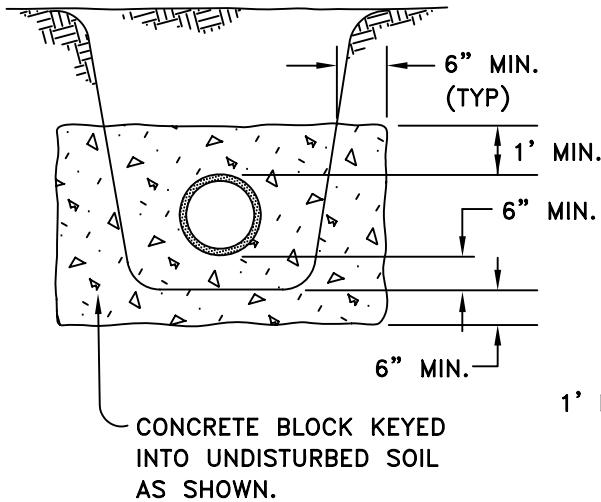

CONCRETE BLOCK KEYED INTO UNDISTURBED SOIL AS SHOWN.

SECTION A-A
N.T.S.

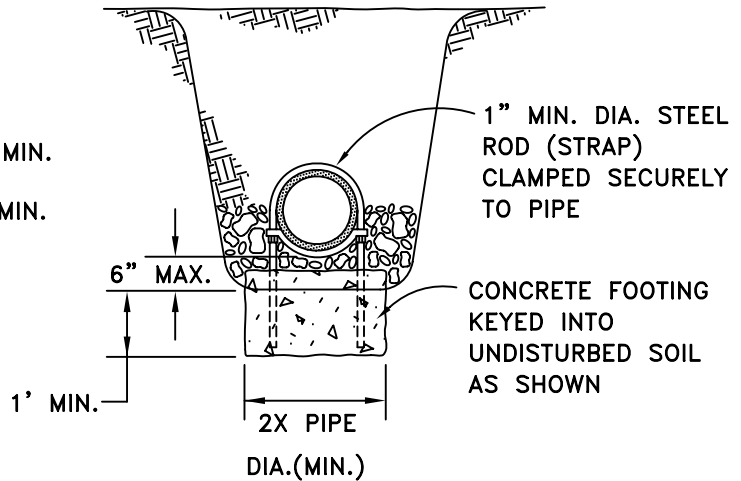

1" MIN. DIA. STEEL ROD (STRAP) CLAMPED SECURELY TO PIPE

CONCRETE FOOTING KEYED INTO UNDISTURBED SOIL AS SHOWN

SECTION B-B
N.T.S.

Date: April 1997

Approved By:

File: E:\eng_std\standard\san_sew

No.	Date	Revision	By	Apvd

Pipe Anchor Detail
For Slopes Greater Than 20%

Detail: SS-9



City of Port Townsend - Public Works Department

Standard Detail

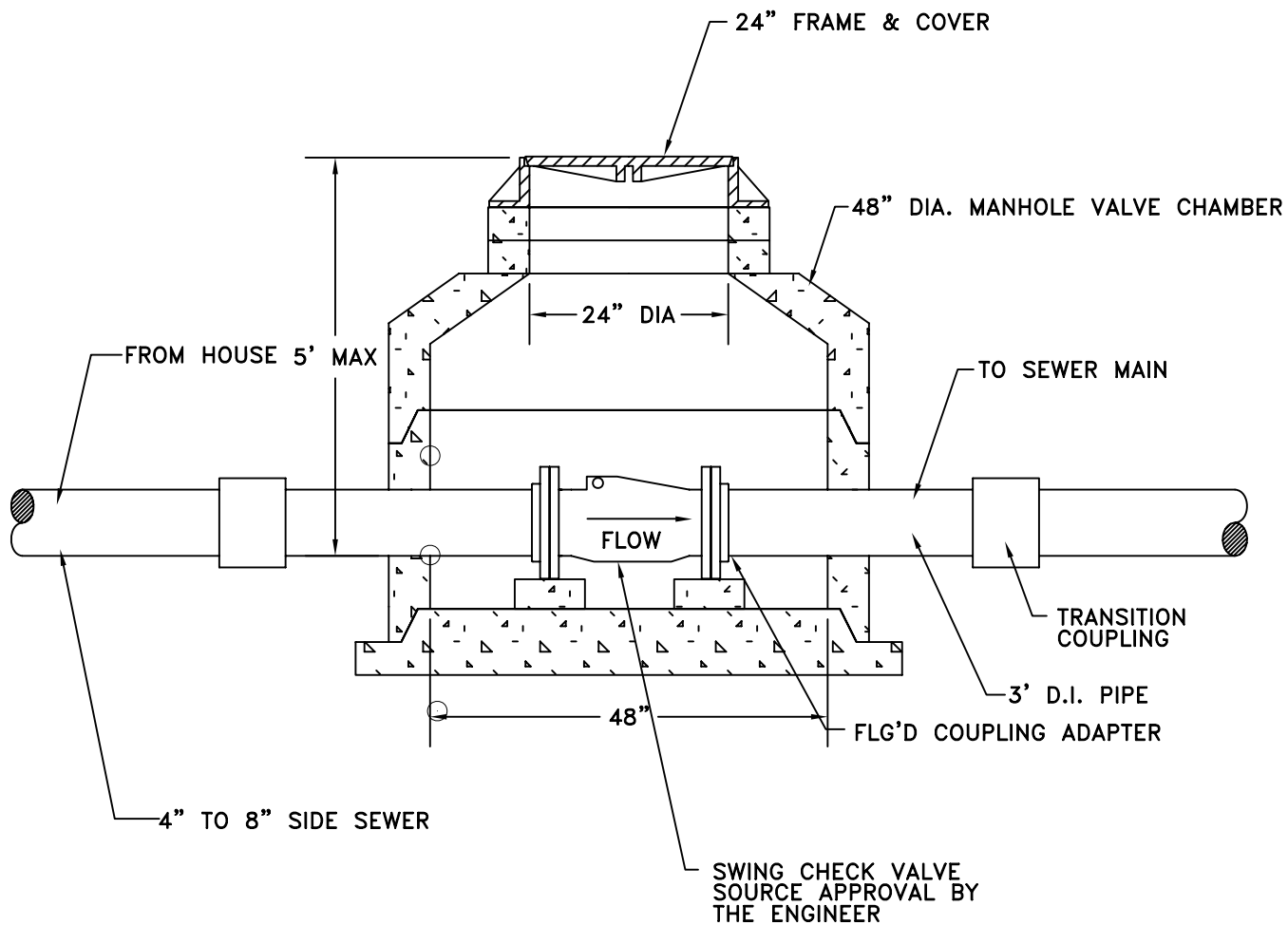

(4" to 8" Diameter)

Date: April 1997	No.	Date	Revision	By	Apvd	<h3 style="margin: 0;">Check Valve Assembly for Joint Use Side Sewer</h3> <p style="font-size: 1.2em; margin: 10px 0 0 0;">Detail: SS-10</p>
Approved By:						
File: E:\eng_std\standard\san_sew						



City of Port Townsend - Public Works Department

Standard Detail

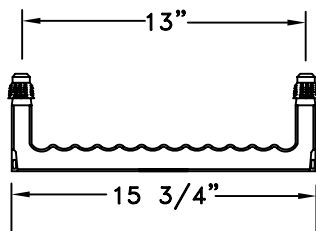

SAFETY STEP

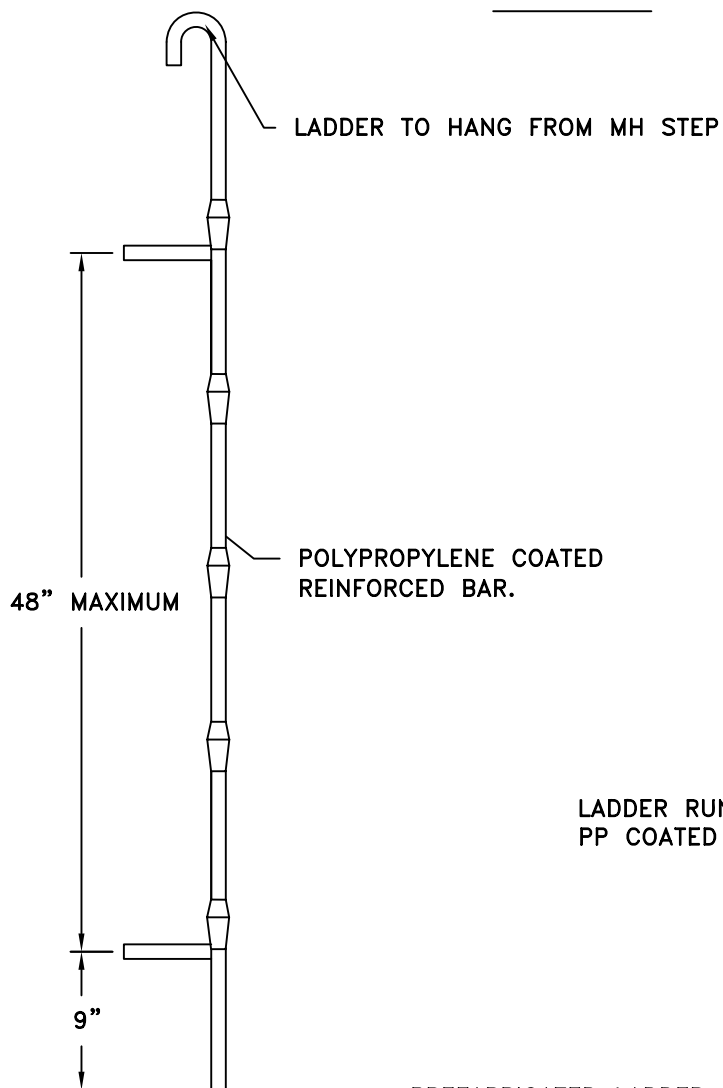

PREFABRICATED LADDER

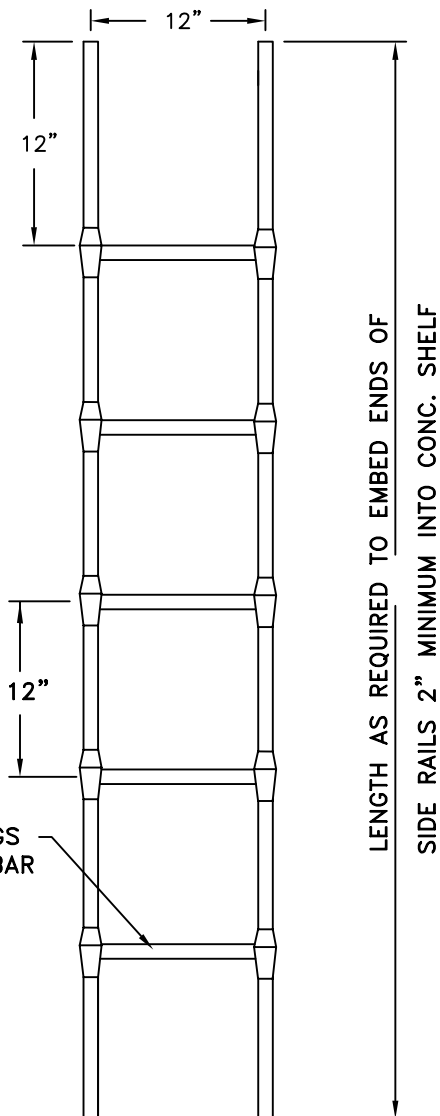

NOTES:

1. ALL STEP SHOULD MEET ASTM C-478 AND AASHTO M-199
2. POLYPROPYLENE SHALL CONFORM TO ASTM D-4101.
3. 1/2" GRADE 60 REINFORCING BAR SHALL CONFORM TO ASTM A-615.



RAIL 9/16" ROUND BAR



RUNG 1/2" GRADE 60

Date: April 1997	No.	Date	Revision	By	Apvd	<h3>Polypropylene Ladder and Maintenance Step</h3> <p style="font-size: 1.5em; margin-top: 20px;">Detail: SS-11</p>
Approved By:						
File: E:\eng_std\standard\san_sew						

7-17.3(4) CLEANING AND TESTING

7-17.3(4)A GENERAL

Sewers and appurtenances shall be cleaned and tested after backfilling by either the exfiltration or low pressure air method at the option of the Contractor, except where the ground water table is such that the Engineer may require the infiltration test.

All work involved in cleaning and testing sewer lines between manholes or rodding inlets as required herein shall be completed within 15 working days after backfilling of sewer lines and structures. Any further delay will require the written consent of the Engineer. The Contractor shall furnish all labor, materials, tools, and equipment necessary to make the test, clean the lines, and perform all work incidental thereto. The Contractor shall perform the tests under the direction and in the presence of the Engineer. Precautions shall be taken to prevent joints from drawing during tests, and any damage resulting from these tests shall be repaired by the Contractor. The manner and time of testing shall be subject to approval by the Engineer.

All wyes, tees, and stubs shall be plugged with flexible jointed caps, or acceptable alternate, securely fastened to withstand the internal test pressure. Such plugs or caps shall be readily removable, and their removal shall provide a socket suitable for making a flexible jointed lateral connection or extension.

If the Contractor elects to test large diameter pipe one joint at a time, leakage allowances shall be converted from GPM per 100 feet to GPM per joint by dividing by the number of joints occurring in 100 feet. If leakage exceeds the allowable amount, corrective measures shall be taken and the line then retested to the satisfaction of the Engineer.

Testing side sanitary sewers shall be for their entire length from the public sewer in the street to the connection with the building's plumbing. Their testing shall be as required by the local sanitary agency but in no case shall it be less thorough than that of filling the pipe with water before backfilling and visually inspecting the exterior for leakage. The decision of the Engineer as to acceptance of the side sanitary sewer shall be final.

If any sewer installation fails to meet the requirements of the test method used, the Contractor shall determine the source or sources of leakage and shall replace all defective pipe. The complete pipe installation shall meet the requirements of the test method used before being considered acceptable. Replacement of defective pipe shall not commence until the Contractor has received approval of his plan from the Engineer.

7-17.3(4)B EXFILTRATION TEST

Prior to making exfiltration leakage tests, the Contractor may fill the pipe with clear water to permit normal absorption into the pipe walls provided, however, that after so filling the pipe he shall complete the leakage test within twenty-four hours after filling. When under test, the allowable leakage shall be limited according to the provisions that follow. Specified allowances assume pre-wetted pipe.

Leakage shall be no more than 0.28 gph per inch diameter per 100 feet of sewer, with a hydrostatic head of 6 feet above the crown at the upper end of the test section, or above the natural groundwater table at the time of test, whichever is higher. The length of pipe tested shall be limited so that the pressure at the lower end of the section tested does not exceed 16 feet of head above the invert, and in no case shall be greater than 700 feet or the distance between manholes when greater than 700 feet.

Where the test head is other than 6 feet, the measured leakage shall not exceed 0.28 gph per inch diameter per 100 feet times the ratio of the square root of the test head to the square root of 6.

$$\text{Leakage maximum} = 0.28 \times \frac{\sqrt{H} - 0.114 \sqrt{H} \text{ gph/inch dia./100ft}}{\sqrt{6}}$$

When the test is to be made one joint at a time, the leakage per joint shall not exceed the computed allowable leakage per length of pipe.

7-17.3(4)C INFILTRATION TEST

Infiltration test leakage shall not exceed 0.16 gph per inch diameter per 100 feet, when the natural groundwater head over the pipe is 2 feet or less above the crown of the pipe at the upper end of the test section. The length of pipe tested shall not exceed 700 feet or the distance between manholes when greater than 700 feet.

Where the natural groundwater head is more than 2 feet, the measured leakage shall not exceed 0.16 gph per inch diameter per 100 feet times the ratio of the square root of the natural groundwater head to the square root of 2.

$$\text{Leakage maximum} = 0.16 \times \frac{\sqrt{H} - 0.114 \sqrt{H} \text{ gph/inch dia./100ft}}{\sqrt{2}}$$

When a suitable head of groundwater exists above the crown of the pipe and when the pipe is large enough to work inside, acceptance may be based on the repair of visible leakage by means satisfactory to the Engineer.

7-17.3(4)D AIR PRESSURE TEST FOR SANITARY SEWERS CONSTRUCTED OF AIR PERMEABLE MATERIALS

(a) Pipelines may be tested with low pressure air by the pressure drop method, in lieu of water infiltration or exfiltration. The pressure drop shall be from 3-1/2 to 2-1/2 psig greater than the average back pressure of groundwater above the centerline of the pipe. At the Contractor's option, pipe may be tested without pre-wetting; however, the test allowances herein assume pre-wetted pipe.

(b) The allowable rate of air loss shall be .003 cfm per square foot of internal pipe surface, but the total air loss shall be not less than 2 cfm nor more than 3.50 cfm.

(c) The test equipment to be used shall be furnished by the Contractor and shall be inspected and approved by the Engineer prior to use. The Engineer may at any time require a calibration test of gauges or other instrumentation that is incorporated in the test equipment.

(d) Safety Provisions. Plugs used to close the sewer pipe for the air test must be securely braced to prevent the unintentional release of a plug which can become a high-velocity projectile. Gauges, air piping manifolds, and valves shall be located at the top of the ground. No one shall be permitted to enter a manhole where a plugged pipe is under pressure. (Four psig air pressure develops a force against the plug in a 12 inch diameter pipe of approximately 450 pounds.) Air testing apparatus shall be equipped with a pressure release device such as a rupture disk or a pressure relief valve designed to relieve pressure in the pipe under test at 6 psi.

(e) Pipe under 36 inches in diameter may be tested from manhole to manhole or such shorter lengths determined by the Contractor. Pipe 36 inches in diameter and over shall be tested one joint at a time. Each joint must show no appreciable loss of pressure when held for 30 seconds.

7-17.3(4)E AIR PRESSURE TEST FOR SANITARY SEWERS CONSTRUCTED OF NON AIR PERMEABLE MATERIALS

7-17.3(4)E1 GENERAL

When non air-permeable pipelines are subjected to the low pressure air test, all of the provisions of Section 7-17.3(4)D shall apply except that the pressure drop shall be from 3.5 to 3.0 psig greater than the average back pressure above the center of the pipe, and the minimum time shall be twice that computed as specified under Section 7-17.3(4)D.

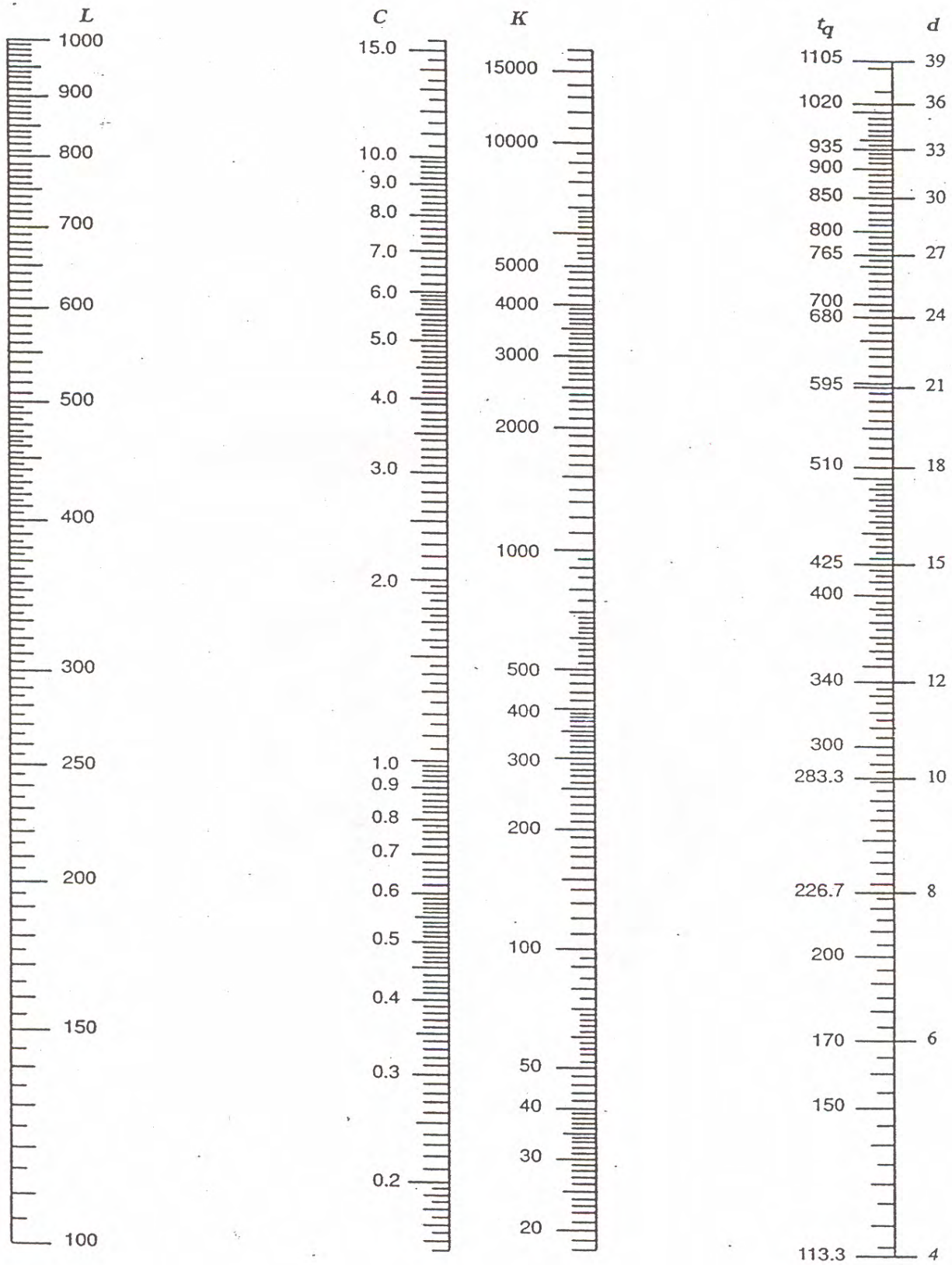

NOMOGRAPH FOR THE SOLUTION OF $K = .011d^2L$, $C = .0003882dL$, $t_q = K/C$