

Chapter 6
TRANSPORTATION

1. General Considerations

- a. The standards and guidelines established by this chapter are intended to represent minimum standards for the planning, design and construction of transportation facilities in conformance with Title 12 of the PTMC, and the goals and policies of the Port Townsend Comprehensive Plan.
- b. The overall goal for the City’s transportation system as outlined in the Transportation Element of the Port Townsend Comprehensive Plan, is “to encourage the uniform development of an integrated, fully accessible, multi-modal, cost-effective public transportation system that will facilitate present and future demand with minimal environmental impact.” Specific goals and policies defined in the Transportation Element include developing transportation standards that:
 - Promote transportation improvements compatible with adjacent land uses
 - Preserve the “small town character”
 - Create a pedestrian- and bicycle-friendly city
 - Encourage narrow streets
 - Encourage safe neighborhood streets with limited access and multiple uses
 - Build an interconnected non-motorized system
 - Promote facilities for transit users
 - Preserve options for uses of public rights-of-way
- c. In conformance with the goals and policies of the Comprehensive Plan, the term “transportation system” and the standards in this chapter apply broadly to vehicular travel, non-motorized travel including bicycle and pedestrian ways, facilities to promote and provide access to transit and other public transportation, telecommunications and private utilities in the right-of-way, and the preservation of public rights-of-way for other public uses.
- d. The standard street sections generally apply for all new streets. For existing streets, each street must be designed on a case by case basis considering the potential impacts of current and future development and the neighborhood scale and design preferences.

2. Definitions

See Chapter 1

3. General Requirements

- a. Whenever new lots are proposed to be created or whenever any type of development is proposed on a parcel or lot, the City may require that streets, alleys, pathways, easements, or rights-of-way be improved and/or constructed to these Standards as a condition to further property development. Such improvements may include pavement, curb and gutter installation, storm drainage control and treatment, design of improvements to future right-of-way grade,

walkways, bikeways, landscaping, driveways, street widening, street lighting/illumination, cul-de-sacs/hammerheads, on-street parking, utilities, signs and/or other traffic control devices, all in conformance with these Standards and the PTMC. No protest agreements for LID formation and/or maintenance agreements may also be required.

- b. For new construction on existing opened streets, improvements in the right-of-way in accordance with these Standards may be required if the street section does not meet current standards. Alternatively, the Public Work's Director may require the property owner to enter into a "no protest" agreement waiving the property owner's rights under RCW 35.43 *et seq* to protest formation of a local improvement district for future street and frontage improvements in accordance with Title 12.
- c. In some cases, the City may allow opening and installation of streets which are not fully developed to the City's street standards. In such instances, the property owner shall sign a no protest agreement to formation of an LID to bring the street up to full standards. The City approves and maintains only those streets which are fully developed to the minimum street standards.
- d. Payback Agreements. The developer of a street may be eligible for partial reimbursement of costs through a Street Latecomer Agreement as defined under Chapter 12.26 PTMC. In certain limited instances, the City may join in the financing of these improvements as described under Alternative Financing Methods Chapter 12.26 PTMC.
- e. Street and Pathway Continuity. The layout of streets and pathways shall provide for the continuation of existing collector and arterial streets and bicycle and pedestrian connections in adjoining subdivisions or of their proper projection when adjoining property is not subdivided. Local access shall be designed to discourage through vehicular traffic; however, pedestrian and bicyclist through-access shall be provided.
- f. Fire Access. Fire access shall be provided in accordance with the local street standards defined by this chapter.
- g. Waivers and Variances. Waivers or variances from these Standards shall be governed by Chapter 12.04 PTMC.
- h. Any design guidelines from the Gateway Plan and the Urban Waterfront Plan shall supersede these Standards.

4. **Permitting, Design, Construction and Approval**

- a. SEPA. A SEPA review may be required by the City for some projects. The Building and Community Development Department will provide information on the applicability of SEPA.
- b. Traffic Impact Study. A traffic impact study may be required to assess the impacts of the proposed project on the City's transportation system. The traffic impact study will assist the City in identifying measures necessary to mitigate the impacts created by the development and to assess concurrency requirements for the development. The traffic impact study is described in Appendix 6F to this

- chapter.
- c. Street Development Permit. A Street Development Permit is required for any improvements to or any work performed within the public right-of-way including clearing, grading, and land alteration.
 - i. Street Development Permit applications shall be submitted on forms provided by the City. When an application is requested, the City will assist the applicant in identifying whether other regulations such as the Environmentally Sensitive Areas (ESA) Ordinance or the State Environmental Policy Act (SEPA) apply.
 - ii. The application shall contain the following information:
 - (1) The name of the owner or agent and mailing address, the street address or name of the premises to be developed, and the legal description of the premises to be developed;
 - (2) The type of development proposed and the building lots, living units and/or the type of activity that will occur within the premises to be developed;
 - (3) A site plan showing the location of the right-of-way and the proposed transportation system improvements;
 - (4) The design drawings and specifications required under Item “g” below in sufficient detail to show that the right-of-way and proposed transportation system improvements will be constructed in conformance with the requirements of these Standards.
 - (5) Any other information deemed reasonably necessary by the director for action upon the application, or as required by SEPA (Chapter 20.04 PTMC), the Subdivision Code (Title 18 PTMC), the ESA Ordinance (Chapter 19.05 PTMC), other city ordinances, and/or subdivision, PUD or other project approval conditions.
 - iii. When the City receives the application, the application will first be checked for completeness. Once the applicant is notified that the application is complete the City will begin its review.
 - iv. Street Development Permit applications and all required submittals and designs are reviewed and approved by the Public Works Director. **The final permit must be approved by the Director prior to any work being performed within the right-of-way.**
 - d. Street Development- Minor Activities Permit. A reduced-fee Minor Activities Permit may be used as an alternative to a full Street Development Permit for the following types of improvements within the right-of-way on an existing street:
 - i. Driveways and paved residential parking areas
 - ii. Drainage improvements
 - iii. Building drain connections
 - iv. Sidewalks and pathways
 - v. Minor clearing and grading activities
 - vi. Street and trail lighting
 - e. Public Works Technical Conference. A technical conference with Public Works

staff is encouraged, and may be required, for anyone planning to open a new street, construct a new street, or make significant improvements in the right-of-way. The applicant must submit a request for the conference, along with a conceptual plan of the development proposal, 14 days in advance of the conference. The submittal shall include the general location of the right-of-way, the development proposal and the proposed transportation system improvements. The public works technical conference will function as a conceptual design review and conceptual level drawings are encouraged. After the request for the conference is received, Public Works will sponsor an internal development review of the proposal and then meet with the applicant to review the proposed site plan and to further define the City's development requirements. Whenever possible, the review by the City and the discussion at the technical conference will be combined with water, sewer, and other utility issues.

- f. Subdivisions and Type II and Type III Permits. The preapplication conference required under Chapter 20.01 PTMC for land use actions is considered to be a separate process from the Public Works technical conference; however, a representative of Public Works will attend the preapplication conference so that the applicant can be informed early on in the development process of applicable standards, regulations and policies so that the application may proceed without delay. The applicant will be notified at the preapplication conference if a subsequent Public Works technical conference will be required.
- g. Construction Drawings and Engineered Plans. All applicants for a Street Development Permit shall submit drawings and specifications as necessary to describe and illustrate the proposed improvements in the right-of-way. If base maps prepared by a licensed land surveyor are available, the design and construction plans shall be submitted on such maps.
 - i. If base maps are unavailable and the public works director determines that a survey is necessary to adequately define the limits of the right-of-way for the purposes of transportation system design and construction, the applicant shall have the right-of-way surveyed by a licensed land surveyor and the plans shall be prepared and submitted on such surveyed base maps.
 - ii. All design and construction plans involving the construction of a new street, or the paving of an existing street, must be prepared, signed and stamped by a Washington State licensed civil engineer. Where paving is required, the engineering design shall be to the next intersection, even if the developer is required to pave only a portion of the street.
 - (1) For new streets in Tier 1 for street construction of one city block (approximately 260 feet) or less, which do not require licensed plans under other authority of other sections of the Port Townsend Municipal Code, the developer has the option of the city performing the engineering for the project at a cost to the developer as set forth in Chapter 3.36 PTMC. Alternatively, the developer may pay for his or her own engineering with the full

cost to be borne by the developer. All other plans shall be prepared at the developer's sole cost.

- (2) The engineered plans shall be prepared on surveyed base maps and shall meet the requirements for plan contents described in Chapter 1.

- h. Inspections, As-Builts, Final Approval and Acceptance. Inspections, as-built submittals, and final acceptance of the improvements by the City shall be as described in Chapter 1.

5. Street Openings and Uses of Existing Public Rights-of-Way

As outlined in the Comprehensive Plan, [Chapter VI, page VI-6 and policies 9.1 to 9.8] it is the City's policy that the currently platted street rights-of-way should be used not only for motor vehicle travel, but should also be preserved and utilized for a variety of other public uses including:

- Non-motorized pathways and connections
- Greenways and open space connections
- Neighborhood stormwater retention facilities
- Preserving environmentally sensitive areas
- Wildlife corridors
- Traffic calming and diversion
- Utility lines

To that end the following items will be considered in determining the opening, use, and design for a public right-of-way:

- a. Public rights-of-way shall be opened for vehicular travel only to the extent necessary to:
 - i. provide access to lots for development
 - ii. provide for a logical street network
 - iii. minimize traffic on any one particular neighborhood street
 - iv. Meet fire access needs
- b. Local access streets should not be opened straight through for several blocks unless traffic calming is provided to slow, discourage, or divert through-traffic. Traffic on local access streets should be directed to neighborhood collector streets.
- c. Rights-of-way designated as "not-to-be-opened" on the City's Street Map due to actual or planned use for non-motorized connections, traffic calming, or other public use such as greenways, open space, wildlife corridor, or stormwater controls or other treatment, shall not be opened for vehicular travel, unless no other access exists for the lot.
- d. Unopened streets should serve in a primary role as pedestrian or bicycle pathways between parallel streets to facilitate non-motorized travel between neighborhoods and street blocks. These pathways should also connect, where possible, to an integrated network linking to other public lands, open space, trails and pathways.
- e. The number of streets opened as through-streets crossing designated primary and secondary pathways for pedestrian and bicycle use shall be minimized.

- f. Rights-of-way shall be preserved as open space when located in the “potential open space connections” overlay from the Port Townsend Comprehensive Plan Land Use Map.
- g. Unopened street ends abutting shorelines (as defined by the Shoreline Master Program) and bluffs shall be preserved for public access (i.e., shall not be vacated). Access by the public to these rights-of-way shall not be restricted, unless special restrictions are requested and approved by the City for reasons of safety.
- h. Street Vacations. Street vacations are discouraged.
 - i. Street vacations will be considered:
 - (1) When the public benefits identified above can still be met or when they are not considered to be applicable to the right-of-way in question in the future.
 - (2) When included as part of a reorientation or replatting of lots and rights-of-way that provides equivalent public benefits for these alternative uses.
 - ii. If a street vacation is approved, the City will generally require that a minimum of a 20-foot easement be preserved for utility and non-motorized uses.
- i. Private Driveways in Public Rights-of-Way
 - i. Private driveways may be allowed in a public right-of-way in certain instances when it can be demonstrated to be in the general public interest. Examples of when a driveway may be allowed, and/or encouraged, include:
 - (1) Minimizing access and intersections onto arterials and collectors
 - (2) Steep slopes that prohibit a through street.
 - (3) When developed in conjunction with a pedestrian throughway.
 - (4) Reducing the amount of impervious surface that would otherwise be created by a fully developed public street.
 - ii. Private driveways in the public right-of-way need not be developed to City street standards; however, a 20-foot minimum paved apron is required where such driveways meet paved streets.
 - iii. Private driveways may serve multiple residences.
 - iv. For private driveways in the public right-of-way:
 - (1) A street use agreement will be required when the City develops this program, and
 - (2) A pedestrian pathway connector shall be provided through the street right-of-way to the next intersection, unless it can be shown this pathway provides no public benefit, and
 - (3) A sign shall be posted indicating this is a public throughway, and
 - (4) Maintenance of the driveway is the sole responsibility of the property owner(s).
 - v. Private driveways are for access only. On-site parking requirements must still be met.

- j. Significant Vegetation.
 - i. All significant trees shall be preserved where possible in the right-of-way outside of the clear Zone needed to construct the street improvements as defined on the Standard Details, unless their removal is approved by the public works director.
 - ii. Unique vegetation, hedgerows, and vegetation providing wildlife habitat shall be preserved in the right-of-way where possible.

6. Existing Streets

- a. Any street that does not meet the current design standards is considered a substandard street.
- b. Gravel and Substandard Paved Streets. A new development on an existing substandard street will generally not be required to make pavement improvements except when necessary to mitigate the direct impacts of the proposed development and/or meet safety requirements.
- c. The level of service standard (LOS) for a gravel street is 70 vehicle trips per day.
- d. Substandard Connecting Streets.
 - i. If the street to be opened and improved to serve the proposed development connects to a substandard street(s) and such substandard street(s) is the only connection to the street network, paving or upgrading of such connecting street(s) may be required. Whether such connecting street(s) must be upgraded or paved shall be based on an individualized analysis of whether such off-site improvements are reasonably necessary to ensure public safety (including but not limited to emergency vehicle access) and/or to mitigate the direct impacts of the development.
- e. No Protest Agreement. Any developer that is not required to construct improvements to minimum (paved) standards shall be required to sign a “no protest agreement” pursuant to Chapter 12.04 PTMC.
- f. Latecomer Agreement. To the extent that the particular proposed development creates the need for upgrading or paving of substandard streets, the developer will be required to pay the full costs of upgrading or paving in order to mitigate the direct impacts of the development and/or to meet safety requirements. The developer may be eligible for a latecomer agreement.

7. New Streets in Previously Platted Rights-of-Way

- a. All unopened street rights-of-way to serve a proposed development shall be graded and paved in conformance with these standards to and through the lot frontage.
- b. The alignment of new streets shall generally be in the center of the right-of-way except as may be necessary to avoid Significant Vegetation and as provided under Section 9 Local Access Streets.
- c. New streets must be designed through to the end of the block to ensure continuity of centerline elevations and drainage.
- d. Construction phasing may be allowed through an approved improvement method

report.

8. Subdivisions and PUDs - General Layout of the Street and Pathway System

For all new subdivisions under Title 18 PTMC (including short plats, long plats and binding site plans), the applicant must consider both motorized and non-motorized travel as an integrated transportation network both within the subdivision and in its connections to the City system. The applicant is encouraged to seek City review of a conceptual site plan early on in the development of a project.

The preliminary plat must consider and include the following:

- a. The street and trail design should reflect the natural character of the area and relate to adjacent sections of the City. Special features of a site shall be preserved where possible.
- b. Street Network. The street network shall:
 - i. Be based on a grid or modified grid pattern [ref Comprehensive Plan Chapter VI, policy 4.8]. A modified grid system is generally intended to provide bicycle and pedestrian access to the same extent as a grid system but limit vehicle through traffic.
 - ii. If cul-de-sacs are used, through access (easement or right-of-way) shall be provided at the end of each cul-de-sac to connect the cul-de-sacs and adjoining open space with a pedestrian and bicycle pathway.
- c. Pedestrians and Bicycle (Non-motorized) Network. A system of sidewalks, trails, walkways, and bicycle paths shall be provided which accomplish the following:
 - i. Promote non-motorized travel as an alternative to motorized travel by providing direct links to neighborhoods, mixed use and commercial districts, and transit pullouts.
 - ii. Maximize the use of off-road trails and pathways.
 - iii. Provide direct through-access with minimal crossings of streets.
 - iv. Cross streets at safe locations and provide signage for the crossings.
 - v. Provide direct connections to the City-wide pedestrian and bicycle network.
 - vi. Build on and enhance the safe-route-to school network.
 - vii. Provide connections to the City's trail and open space system.
 - viii. Preserve existing trails to the maximum extent possible.
- d. Adequate buffering (landscaping and/or setbacks) along arterials and major collectors shall be provided to screen residences from dust, noise and other traffic impacts.

9. Local Access (Neighborhood) Streets

It is the vision of the Port Townsend Comprehensive Plan that neighborhood streets shall be shared for motorized, non-motorized, and neighborhood scale use and that they be designed to be safe for pedestrians. Practices and designs to control speeds and assure safe streets are encouraged. Some examples of traffic calming and neighborhood streetscapes are included in Appendix 6B.

- a. The following shall be considered in the layout and design of neighborhood

streets:

- i. Maintain neighborhood scale
- ii. Preserve vegetation
- iii. Use narrow streets to reduce stormwater runoff and reduce costs
- iv. Discourage through traffic
- v. Provide separate pedestrian access through and between blocks
- b. Neighborhood street design shall focus not only on the needs of the automobile, but also on the needs of children, pedestrians, residents, and bicyclists.
- c. Neighborhood streets shall provide vehicle access for residents on the street, and allow traffic movement but should discourage through access for motor vehicles. Traffic calming and other methods to slow traffic speeds and enhance pedestrian and bicycle safety should be considered and include:
 - i. Traffic circles at intersections
 - ii. Not opening streets all the way through to the next intersection
 - iii. Circuitous routes for through-traffic, for example a broken street grid
 - iv. Closing existing street ends
 - v. Textured pavement
 - vi. Medians at intersections
 - vii. Speed tables
 - viii. Chicanes
 - ix. Curved streets
 - x. Bulb-outs, pinch points, pavement narrowing, and pocket parking
- d. Innovative street designs and access control methods to meet the goals for neighborhood streets are encouraged by the City.

10. Multi-family (RIII or RIV), Mixed Use, Commercial Development

- a. A separated, internal pedestrian circulation system shall be provided in all new developments in all RIII, RIV, M and C zones (Policy 5.3b)
- b. Through access or connectors to the non-motorized network shall be provided.
- c. Driveways and entrances onto collectors and arterials should be minimized and shared where possible.

11. Level of Service Standards

- a. Any new development proposal may be required to perform a traffic impact analysis and assess the impact on traffic for the existing streets.
- b. Where a project is served by a street system of arterials and collectors that is below level of service D or will fall below LOS D as a result of the development, the GMA concurrency requirements must be met.

12. General Design Standards

- a. Street pavement design must provide for the maximum vehicle weight loading conditions anticipated.
- b. The design of streets and other improvements shall depend upon their type and usage. The design shall conform in functionality and overall design concept

to the standard sections of the various classifications of streets as shown on Standard Details T-3 to T-12 and as described in Table 6-1. The standard roadway sections establish the general construction requirements. The actual design of each street must consider the intensity of adjacent development, localized drainage and soil characteristics, slope, existing vegetation, safety, traffic calming, and other conditions. Innovative street design is encouraged.

- c. Alignment. Alignment of arterials and collectors shall conform as nearly as possible with that shown in the Arterial Street Plan as amended by the Comprehensive Plan.
- d. Grade. Street grade shall conform to the natural contour of the land as closely as possible. In some cases a different grade may be required by the Public Works Director. The minimum allowable grade shall be 0.5 percent and the maximum allowable grade shall vary, depending upon the street classification, surrounding soils, pavement type, and fire access.
- e. Cross slope. The crown of the street shall slope at a minimum of 2% grade to the street edge.
- f. Width. The pavement and right-of-way width depend upon the street classification. Table 6-1 and the Standard Details define the minimum widths allowed. Street widths shall be measured from face of curb to face of curb on streets with cement concrete curb and gutter or asphalt curbs, or from the inside edge of the shoulder. Streets constructed less than 26 feet wide may be required to be posted with no parking if access for emergency vehicles becomes restricted. Street widths may be reduced by providing pocket parking, bulb-outs, pinch points and other traffic calming features.

13. Functional Classification

- a. City streets are designated as Principal Arterials, Minor Arterials, Major Collectors, Minor (Neighborhood) Collectors, Boulevards, Scenic Collectors, or Local Access Streets. The classification of existing and proposed streets is shown on Figure 6-1, and is listed below. These classifications are based on existing use patterns and may be reviewed periodically and adjusted. Future use patterns may change these designations. New streets shall be classified by, and existing Streets may be reclassified by, the Public Works Department.
 - i. Principal Arterials:
 - (1) “Forest Corridor” - Sims: City Limits to Howard Street
 - (2) “Upper Commercial District” - Sims: Howard Street to Sheridan
 - (3) “S - Curve Corridor” - Sims: Sheridan to 10th
 - (4) “The ‘Flats’ Commercial District” - Sims: 10th to Kearney
 - (5) “Bluff Corridor” - Water Street: Kearney to Ferry Terminal
 - ii. Minor Arterials
 - (1) Hastings: City Limits to Discovery Road
 - (2) Sheridan: Sims to Hastings
 - (3) F: San Juan to Tyler
 - (4) Tyler: F St. to Lawrence

- (5) 19th: Sheridan to Kearney
- (6) San Juan: 19th to Admiralty
- (7) Kearney: Sims to Blaine
- (8) Lawrence: Kearney to Monroe
- (9) Water: Ferry Terminal to Monroe
- (10) Monroe: Lawrence to Water
- (11) Discovery Road: Hastings to F St.
- (12) New Street: Howard St general alignment: Sims Way to Hastings Ave.
- iii. Major Collectors:
 - (1) McPherson: Sims to Discovery Bay
 - (2) 12th: Sheridan to Sims
 - (3) 14th: Discovery Bay Rd. to Sheridan
 - (4) Landes: 12th to 19th
 - (5) 9th: McPherson to Sheridan
 - (6) Redwood: Cherry to Admiralty
 - (7) Cherry: Redwood to Walker
 - (8) Walker: Cherry to Washington
 - (9) Monroe: Roosevelt to Lawrence
 - (10) Washington: Sims to Monroe
 - (11) Quincy: Water to Jefferson
 - (12) Jefferson: Quincy to Tyler
 - (13) Tyler: Jefferson to Lawrence
 - (14) Fir: F to Benton
 - (15) Harrison: Washington to F
 - (16) Benton: Washington to Blaine
 - (17) Discovery Road: 19th to Hastings
- iv. Minor (or Neighborhood) Collector
 - (1) Cherry: Redwood to W
 - (2) Fir: F to U
 - (3) U: Cherry to Fir
 - (4) Grant: South of Sims Way
 - (5) Silver: Hastings to Umatilla
 - (6) Sheridan: Hastings to Silver
 - (7) Center: San Juan to Cherry
 - (8) Jackman: 43rd to 49th
 - (9) Hendricks Street: North of 49th
- v. Boulevards - none designated to date
- vi. Scenic Collectors
 - (1) Cook Avenue: City Limits to 49th
 - (2) 49th: Hendricks to San Juan
 - (3) San Juan: 49th to Admiralty
 - (4) Admiralty: San Juan to W
 - (5) W: Admiralty to Walnut
 - (6) Walnut: W St to Q

- (7) Q: Walnut to Jackson
- (8) Jackson: Q to Roosevelt
- (9) Discovery Road: City Limits to Sheridan
- vii. Local Access Streets - all other streets not identified above

14. Naming and Addresses

Street numbers are provided by the City and are assigned with the building permit. Street names for existing platted rights-of-way shall be as shown on the plat maps. Names for new streets shall be submitted for approval with the preliminary plat.

15. Signage

- a. Street Name Signs. Street signs shall be provided by the developer at all intersections. The design shall be per the U.S. Department of Transportation Manual on Uniform Traffic Control Devices (MUTCD).
- b. Construction Traffic Control. The developer is responsible for providing all construction traffic control signs, devices and flagging. Traffic control signing and devices shall comply with the provisions as established by the WSDOT Standard Plans.

16. Right-of-Way Width and Dedications

- a. As further set forth in Chapter 12.04 PTMC, right-of-way widths deeded to the city for streets and other improvements shall be as required for each functional clarification of streets to accommodate motorized and non-motorized transportation, landscaping, drainage, utility and buffer requirements. Right-of-way width is generally determined by the functional classification of the street. The typical right-of-way for each classification is shown on the Standard Details and in Table 6-1.
- b. Right-of-way requirements may be increased if additional travel lanes, turn lanes, transit lanes, bus loading zones, operational speed, bike lanes, utilities, drainage, schools, or other factors require greater width as determined by the Public Works Director. A reduction in the minimum right-of-way requirement may be granted by the Public Works Director where it can be demonstrated that sufficient area has been provided for current and future functions within the right-of-way and/or alternate locations.
- c. Easements for other public systems shall be provided as required. Particular design features of a road may necessitate slope, retaining wall, or drainage easements. Examples of other cases where easements may be required by the Public Works Director include temporary construction, right of entry, walkway, pedestrian, street lighting, traffic control devices, and to implement the city's Non-Motorized Plan.
- d. All development may be required to deed additional right-of-way, as a condition of approval of the development if the development abuts an existing substandard public street and the additional right-of-way is necessary to incorporate future street improvements necessary for public safety. All right-of-way shall be

conveyed to the City on a recorded plat or by right-of-way dedication deed.

17. Private Streets or Access Easements

- a. Private streets may be allowed under the following conditions:
 - i. Permanently established by plat or easement providing legal access to serve dwelling units or businesses on separate parcels, or dwelling units or businesses situated on one parcel sufficient to accommodate required improvements, to include provisions for future use by adjacent property owners when applicable, and;
 - ii. Meet city minimum design standards except for right-of-way requirements and approved waivers, and;
 - iii. Accessible at all times for emergency and public service vehicle use, and;
 - iv. An agreement is signed indicating that the city will not be responsible for roadway maintenance costs associated with use of the road by emergency vehicles and service vehicles, and;
 - v. Will not result in land locking of present or future parcels nor obstruct public street circulation, and;
 - vi. Covenants have been approved, recorded, and verified which provide for maintenance of the private street by the owner or homeowners association or other legal entity and allows the use of the street by service vehicles at no cost for maintenance to the city.
- b. Acceptance as Public Streets. Acceptance of private streets as public streets will be considered only if the street(s) meet all applicable public street standards, including right-of-way.

18. Street Frontage Improvements

- a. All new development shall install street frontage improvements required by these Standards as a condition of development. Such improvements may include pavement, curb and gutter; walkways; bikeways; storm drainage; lighting; traffic control devices and signal; utility relocation and/or undergrounding; and street widening all per Chapter 12 PTMC and these Standards.
- b. All frontage improvements shall be made across the full frontage of the property and shall match the adjacent street improvements and meet the required minimum street section.
- c. Disturbances in the right-of-way shall be limited to those necessary to construct the improvements described in the approved street development permit. Any street or street frontage damaged as a result of the development shall be returned to its original condition or better. Vegetation and existing contours shall be preserved to the extent possible. Revegetation and slope stabilization methods shall be employed to prevent safety and drainage and erosion problems during and after completion of construction.
- d. Waiver: Frontage improvements may be waived per the criteria under Title 12. If frontage requirements are waived, the applicant may be required to sign a no-protest agreement to the formation of a future Local Improvement District (LID)

to install the improvements.

19. Street Ends

- a. Fire apparatus turnarounds shall be required for every building hereafter constructed when any portion of an exterior wall of the first story is located more than 260 (one city block) feet from fire department vehicle access. In such case, cul-de-sacs or other fire apparatus turnaround complying with these standards shall be provided at all public and private dead-end streets, including street ends in subdivisions.
- b. Motor vehicle turn-arounds in conformance with these standards shall be provided when more than three houses are located on a dead-end street or where topography or other constraints merit the need for a turn-around that does not require a fire apparatus turnaround.
- c. Cul-de-sacs. A minimum easement of 20 feet shall be provided at a street end or Cul-de-sac for through-passage of non-motorized pathways and for utilities.

20. Intersections

- a. Traffic control will be as specified in the Manual of Uniform Traffic Control Devices (MUTCD) or as modified by the Public Works Director as a result of appropriate traffic engineering studies.
- b. Angle of Intersection: 75 to 105
- c. Minimum Centerline Radius: See Table 6-1.
- d. Typical Curb or Curve Radius: See Table 6-1. Radius depends on design vehicle.
- e. Reverse curves: Separated by tangents of at least 100 feet may be reduced in business districts where bulb-type intersections are desired length.
- f. Minimum Street Centerline Separation of Intersections:
 - i. Local access,
 - (1) When new right-of-way is being dedicated: 150 feet
 - (2) At all other times 150 feet is the goal; street opening will be reviewed to achieve this.
 - ii. Local access or Collectors intersecting arterials: 300 feet
 - iii. Local access or Collectors on Sims Way in the Gateway Corridor: Shall be in conformance with the Gateway Plan.
- g. Sloping approaches: Landings are not to exceed two feet difference in elevation for a distance of 30 feet approaching an arterial or 20 feet approaching a neighborhood collector or local access street, measured from the back of a walkway or the edge of the pavement if no walkway exists.
- h. Street Grades
 - i. All changes in street grades shall be connected by vertical curves of a minimum length of 200 feet, unless otherwise specified by the Public Works Director.
 - ii. The surface of all streets in the city, when graded, shall have a slope or incline from the crown in the center to the sides of the street of two

percent.

21. Street Sections

- a. For typical sections for minor arterials, collectors and local access streets, see Standard Details T-3 to T-12. For Sims Way see Gateway Plan.
- b. The requirements for facilities within the street rights-of-way and required street cross-sections for each functional classification are also described in Table 6-1. Facility requirements include travel lane widths, shoulders, surfacing requirements, bikeways, and walkways.
- c. Travel Lane Width:
 - i. Travel lane widths depend on the street classification. Minimum travel lane widths shall be as shown on the Standard Details.
- d. Surfacing Requirements:
 - i. All new streets shall be paved, except as provided under Chapter 12.04 PTMC.
 - ii. The following are minimum requirements for travel lane surfacing for the various roadway classifications.
 - (1) Principal Arterials: as per Standard Specifications of WSDOT for SR 20
 - (2) Minor Arterials and Collectors: See Standard Detail T-2.
 - (3) Local Access Streets: Standard Detail T-2.
 - iii. All minimum surfacing and base material requirements assume an acceptable, well drained, stable, compacted subgrade. Additional requirements may be required by the Public Works Director if suitable subgrade conditions are not met.
- e. Drainage. The streets section and street edge shall be designed to adequately handle stormwater runoff from the street, adjacent properties, and upstream flow coming onto the street.
 - i. Street edge and curb design must consider local drainage, soils conditions, drainage quantities coming from offsite, slope, and other local factors
 - ii. Street edge types include curb and gutter, asphalt wedge curb, and shoulder with swale or ditch.

22. On-Street Parking

- a. Arterials and Collectors: Parking shall generally not be provided or allowed on arterials and collectors except in mixed use zones or other areas where the street cross section has been designed to allow for it with travel and bike lanes free for vehicular travel. Special parking lane requirements and widths shall be as shown on the Standard Details and Table 6-1.
- b. Local Access Streets: Parking needs must be met off the paved surface as needed by the development.

23. Pedestrian Walkways (including Sidewalks) and Multi-Use Pathways

- a. Walkways and pathways shall be provided for the following locations and types

of development:

- i. Along both sides of all arterials and major collectors
 - ii. Along one side of minor collectors and scenic arterials and collectors
 - iii. Along designated current and future safe-routes-to-school
 - iv. Frontage for all Multifamily (RIII, RIV), Mixed Use, Commercial and Manufacturing developments
 - v. For all new subdivisions and PUDs per Section 8.
 - vi. For unopened streets per Section 5
 - vii. To fill gaps in the existing sidewalk network
 - viii. Where designated by the Non-Motorized Plan.
- b. A waiver to the walkway requirement may be granted by the Public Works Director
- i. When an equivalent pathway or other safe route is available for pedestrians and bicycles,
 - ii. Where the area is built out to densities such that installation of a single sidewalk section will serve little public benefit, or
 - iii. As otherwise provided in the waivers under Title 12.
- c. Accessibility. All walkways in the public right-of-way shall be constructed to comply with the Washington State Barrier-free Design (WAC 51.30). In accordance with State law (WAC 51.30), if walkways are required to be installed, wheelchair access ramps shall be provided at all pedestrian crossings with curb sections. Form and subgrade inspection by the City is required before a concrete sidewalk is poured.
- d. Width and Surface Material
- i. See Standard Details (Appendix 6A) and Appendix 6-C for general layout and construction details of pathways and sidewalks.
 - ii. All sidewalks on Water Street from Jackson to Walker Street, on Washington Street from Jackson to Taylor, on Tyler Street, Adams Street, Quincy Street, Madison Street and Monroe Street at all points between Water Street and Jefferson Street hereafter constructed, or reconstructed on either side of the streets named shall be designed in conformance with the Port Townsend Streetscape Design Workbook, dated December 16, 1987, which is adopted herein by reference.
 - iii. Principal Arterials (SR20): provide walkways in accordance with the Gateway Plan and Standard Details T-1A through T-1F.
 - iv. Minor Arterial and Collector Streets: Minimum widths are shown on the Standard Details. Concrete sidewalks (Standard Detail T-15) are required in multi-family, commercial, and other non-residential zones. Asphalt or alternative surfacing materials may be considered in residential zones.
 - v. Multi-Use Pathways: Multi-use pathways as defined in the Non-motorized Plan and where required in new subdivisions, shall be asphalt paved unless otherwise approved by the Public Works Director.
 - vi. Local Access Streets: concrete sidewalks are required along the street frontage where necessary to fill gaps in existing sidewalk network, on

designated school walk routes and where shown in the Non-Motorized Plan. Otherwise, local access shall be designed for pedestrian and bicycle safety per Section 9.

- vii. Other Pathways: The minimum construction standard for new unpaved walkways and pathways is four (4) inches in depth of compacted 1/4 minus crushed rock.

24. Transit and School Bus Connections

- a. Transit serviceable site plans and transit supportive features are required for all new developments, when appropriate and feasible.
- b. New developments may be required to construct transit pullouts and/or shelters when necessary to mitigate the impacts of the development and provide for transportation demand management.
- c. Pedestrian connections shall be provided through developments to transit shelters and transit pullouts.
- d. The Jefferson Transit Comprehensive Plan, when complete, shall serve as the basis for establishing transit routes and required facilities.
- e. Public transit passenger shelters adjacent to bus zones may be placed within the curbside obstruction-free zones established by the Port Townsend Streetscape Design Workbook, dated December 16, 1987, which is adopted herein by reference.
- f. Transit pullouts and shelters, where appropriate, shall be provided on all new arterials and major collectors and on existing arterials and major collectors when these streets are upgraded. Crosswalks shall be included in the design
- g. School Bus needs shall be considered in concert with public transit in site plans and street design. The City and Port Townsend School District will use the following criteria in placement and design of school bus stops:
 - i. A school bus stop shall be required for each new residential subdivision or apartment complex where school children are to be boarding or deboarding unless it is determined by the School District that a new bus stop is not required because adjacent facilities already exist for the site.
 - ii. Placement shall be determined by the School District and the City.
 - iii. Location of school bus stops shall be designed with safety as a paramount concern.
 - iv. School bus stops shall be designed to compliment the residential environment and provide convenient location and access for neighborhood children including sidewalk access.
 - v. Every effort shall be made to make school bus stops and sidewalk access to school bus stops a safe and friendly pedestrian environment.

25. Bikeways

- a. Bikeway: Any trail, path, part of a highway or shoulder, sidewalk, or any other travel way s designated, signed, marked or used for bicycles. Bikeways are categorized as follows:

- i. Class I Bikeway (Bike Path): A separate trail for the principal use of bicycles that may be shared with pedestrians.
 - ii. Class II Bikeway (Bike Lanes): A portion of a street designated by signs and/or pavement markings for preferential bicycle use
 - iii. Class III Bikeway (Bike Route): A street designated with signs as a bicycle route and is shared with other transportation modes
 - iv. Class IV Bikeway (Shared Roadway with no Designation): A publicly maintained street that is not designated with signs and/or pavement markings as a bikeway but is accessible to bicyclists.
- b. Requirements for Class II bikeways on arterials and collector streets are as shown on Table 6-1 and on the Standard Details. Other classes of bikeways may be required based on the Non-Motorized Plan.

26. Driveways

- a. Driveway access onto arterials and collectors shall be avoided wherever possible. Driveway access shall not be allowed where other lot access methods exist and/or where access onto the street is considered to be unsafe.
- b. All driveways on lots which abut any arterial or collector street within the city shall either loop within the lot and provide separate points of access and egress to the street, or shall have an adequate turnaround within the lot so that vehicular traffic onto the street from such lot may enter the street by forward rather than backward movement. Joint use at property lines is encouraged.
- c. Width
 - i. The maximum driveway width shall be 20 feet for residential uses and 30 feet for commercial uses. A wider commercial driveway width may be approved by the Public Works Director, where a substantial percentage of oversized vehicle traffic exists. In this case, the driveway should be sized to accommodate the largest vehicles. Where intersection openings are approved, the width shall be as determined by the Public Works Director.
 - ii. Maximum one-way driveway width shall be 12 feet for residential and 22 feet for commercial driveways. Parking lot circulation needs shall be met on site. The public right-of-way shall not be utilized as part of a one way parking lot flow.
- d. Surface - All driveways shall be paved within the right-of-way except when fronting on an existing gravel street, in which case paving of driveways shall be included in the no-protest agreement to a LID. Semi-pervious pavement surfaces may be considered as an alternative to paving.
- e. Conditions of Approval
 - i. All abandoned driveway areas on the street frontage to be improved shall be removed and necessary drainage and walkway shall be installed.
 - ii. Left turns from and to a driveway may be restricted as a development condition or in the future if such maneuvers are found to be unduly hazardous.
 - iii. Driveways shall be aligned wherever possible with existing driveways on

- iv. Design of access points along SR 20 within the Gateway Corridor shall be consistent with the “Detailed Access Management Plan” in the **Gateway Development Plan** (Dated August 2, 1992).
 - v. All driveways shall be angled ninety-degrees to the street, unless designated as right turn only with the approval of the Public Works Director.
 - vi. In commercial areas driveways should be consolidated at the property line for adjoining businesses.
 - f. Location and Number of Driveways
 - i. Location of driveways shall be in the safest location available and shall be generally as shown on the Standard Details.
 - ii. When measuring distances to or between driveways, the nearside edge of the driveways line shall be used as a reference.
 - iii. Back edge of driveway shall be at the same elevation as the back of the walkway or shoulder adjacent to the driveway approach.
 - iv. No object (including fire hydrants, light or power poles, street trees) shall be placed within five (5) feet of the driveway edge.
 - v. On sloping approaches, a landing shall be provided per Section Intersections.
 - vi. Approach grades and configuration shall accommodate future street improvements to prevent major driveway reconstruction.

27. Sight Obstruction Requirements

- a. An unobstructed view shall be maintained at all driveways, building or garage entrances.
- b. Sight lines to traffic control devices (signs, signals, etc.) should not be obscured by landscaping, street furniture, marquees, awnings or other obstructions. Refer to Manual of Uniform Traffic Control Devices and WSDOT Design Manual for required sight lines.
- c. Clear vision area: The clear vision area is a clear view triangle formed at the intersection of two streets as shown on the Standard Details. The clear vision area shall be subject to the following restrictions to maintain a clear view at intersection approaches:
 - i. The vertical clearance within the clear vision area shall be free from obstructions to a motor vehicle operator’s or bicyclist’s view between a height of 3 feet and 8 feet above the surface of the street.
 - ii. Exclusions. Sight obstructions that may be excluded from these requirements include: conforming fences, utility poles, regulatory signs, trees trimmed from the base to a height of 8 feet, places where the contour of the ground prevents cross visibility, saplings or plant species of open growth habits and not in the form of a hedge which are so planted and trimmed as to leave at all seasons a clear and unobstructed cross view, buildings constructed in conformance with the provisions of the zoning

regulations, and preexisting buildings.

- d. Any trees within 10 feet of the edge of the roadway or parking must have a visual and physical vertical clearance of 13 feet 6 inches over traveled roadway.

28. Surveying and Monumentation

- a. All street grades, curb and gutter, sidewalks and other improvements shall be staked by a surveyor or engineer prior to construction.
- b. Surveying of land corners shall be required to establish right-of-way lines for all new streets, unless waived by the Public Works Director. Such waiver may be given when right-of-way can be clearly determined without a survey.
- c. Street monumentation: See Chapter 1.
- d. Monumentation details are shown on the Standard Details.
- e. Whenever surveying or monumentation is required it shall be performed in accordance with Chapter 1, Section 1.18 of these Standards.

29. Delivery Boxes (Mail and Newspaper)

- a. Delivery boxes shall be clustered together when practical and when reasonably convenient to the houses served.
- b. When delivery boxes are located in the walkway, individually or in clusters, the walkway shall be widened or offset to provide the full design width around the mail boxes.
- c. In the case of new road construction, or reconstruction requiring mail boxes to be moved back or rearranged, the designer and builder shall coordinate the location with the U.S. Postal Service.
- d. Mail boxes, in the general case, shall be set:
 - i. Bottom or base of box 44 inches above road surface.
 - ii. In relation to curb or sidewalk: front of mailbox one foot back of vertical curb face or outside edge of shoulder.
 - iii. Delivery boxes shall be located so that destruction of the roadside or shoulder shall not occur as a result of delivery of newspapers or mail. If damage occurs, the mailbox shall be relocated or a paved shoulder or pocket pull-out provided.

30. Street and Trail Illumination

- a. The City's overall policy is to minimize street lighting except as needed for safety.
- b. If a resident or group of residents or property owners, desire the installation of a new street light, they must apply to the Public Works Director with a Street Development Minor Activities Permit. The Director may contact impacted neighbors or businesses to determine the general public desire for the light. The Public Works Director will review the application in view of the City's overall lighting policy and must balance safety with O&M costs and will consider neighborhood support or opposition. All street lighting shall be reviewed and approved by the Public Works Director prior to installation. All lighting design

- and installation costs shall be paid for by the applicant(s).
- c. Street illumination shall typically be provided on all new arterials and collectors to address safety and pedestrian concerns. Typical distance is 260 feet apart and/or at intersections.
- d. For new developments, provide street lights commensurate with the neighborhood characteristics and density considering:
 - i. The City’s policy to minimize lighting
 - ii. Aesthetics
 - iii. Pedestrian and vehicular safety
 - iv. Existing and projected traffic volumes
 - v. Location of schools and transit stops
 - vi. High density or intensity land uses
 - vii. Proximity to the intersection
 - viii. Relevant state, federal, local or utility design requirements
- e. General Considerations
 - i. All public street light designs shall be prepared and approved by the power company with jurisdiction in the area or by a licensed engineer experienced in lighting design. The design calculations should indicate luminaire spacing, illumination levels, line losses and the electrical and physical layout of the system, including its connection to the existing system.
 - ii. All street lights are to be equipped with high pressure sodium vapor lighting and lighting shields to control “light pollution.”
 - iii. All street light installations including wiring, conduit, and power connections shall be located underground. Exception: existing residential areas with existing above ground utilities, in which case street lighting may be installed on the existing power poles.
 - iv. On-site lighting shall be hooded and shielded so that it is directed on the project site and does not impact adjacent property.
- f. Trails. Lighting of trails may be required where necessary for safety.

31. Temporary Street Patching

- a. Temporary restoration of trenches shall be accomplished by using 2” Class B Asphalt Concrete Pavement when available, 2” medium-curing (MC-250) Liquid Asphalt (cold mix), 2” Asphalt Treated Base (ATB), or steel plates.
- b. ATB used for temporary restoration may be dumped directly into the trench, bladed, and rolled. After rolling, the trench must be filled flush with asphalt concrete pavement to provide a smooth riding surface.
- c. All temporary patches shall be maintained by the contractor until such time as the permanent pavement patch is in place.

32. Trench Backfill and Restoration

Trench restoration shall be either by a patch or patch plus overlay as required by the City. Restoration shall be as described below unless the existing condition of the street does

not justify full restoration per these standards.

- a. All trench and pavement cuts shall be made by spade bladed jackhammer or sawcuts. The cuts shall be a minimum of one (1) foot outside the trench width.
- b. All trenching shall be backfilled with crushed surfacing materials conforming to Section 4-04 of the WSDOT/APWA Standard Specifications. The trench shall be compacted to 95 percent maximum density, as described in Section 2-03 of the WSDOT/APWA Standard Specifications.
 - i. If the existing material is determined by the City to be suitable for backfill, the contractor may use the native material except that the top of the trench shall meet the pavement section requirements of Standard Detail T-2. All trench backfill materials shall be compacted to 95% density.
 - ii. Backfill compaction shall be performed in six (6) inch lifts.
 - iii. Controlled density backfill (CDF) may be used or required by the City as an alternative for trench backfill.
- c. Replacement of the asphalt concrete or Portland concrete cement shall be of existing depth plus one (1) inch or three (3) inches, whichever is greater.
- d. Tack shall be applied to the existing pavement and edge of cut and shall be emulsified asphalt grade CSS-1 as specified in Section 9-02.1(6) of the WSDOT/APWA Standard Specifications. Tack coat shall be applied as specified in Section 5-04 of the WSDOT/APWA Standard Specifications.
- e. For pavement cuts less than 8 feet wide, asphalt concrete Class B shall be laid by hand and compacted using an asphalt roller. For pavement cuts greater than 8 feet wide the asphalt shall be placed on the prepared surface by an approved paving machine in accordance with the applicable requirements of Section 5-04 of the WSDOT/APWA Standard Specifications. Longitudinal joints between successive layers of asphalt concrete shall be displaced laterally a minimum of twelve (12) inches unless otherwise approved by the City Engineer. Fine and coarse aggregate shall be in accordance with Section 9-03.8 of the WSDOT/APWA Standard Specifications. Asphalt concrete over two (2) inches thick shall be placed in equal lifts not to exceed two (2) inches each.
 - i. All street surfaces, walks, or driveways within the street trenching areas affected by the trenching shall be feathered and shimmed to an extent that provides a smooth-riding connection and expeditious drainage flow for the newly paved surface. Shimming and feathering as required by the City Engineer shall be accomplished by raking out the oversized aggregates from the Class B mix as appropriate.
 - ii. Surface smoothness shall be per Section 5-04.3(13) of the WSDOT/APWA Standard Specifications. The paving shall be corrected by removal and repaving of the trench only.
- f. All joints shall be sealed using paving asphalt AR4000W.
- g. When trenching within the roadway shoulder(s), the shoulder shall be restored to its original or better condition.
- h. The final patch shall be completed as soon as possible and shall be completed

within thirty (30) days after first opening the trench. This time frame may be adjusted if delays are due to inclement paving weather or other adverse conditions that may exist. However, delaying of final patch of overlay work is allowable only subject to the City Engineer's approval.

- i. For any new asphalt streets, no cuts will be allowed for five (5) years. Direction drilling or boring will be required in these situations.

33. Traffic Control

- a. Traffic control is required whenever work occurs that may obstruct traffic flow in the right-of-way.
- b. Signing: The developer shall install all traffic control signs in accordance with MUTCD standards which shall include but not be limited to street name, parking, stop, dead end, and pedestrian signing.
- c. Traffic Signal Modification: Traffic signal modification designs shall be prepared by a licensed engineer experienced in traffic signal design.
- d. For new arterials and collectors, pavement markings, including buttons, paint, thermoplastics and delineators are required for roadway safety. Bicycle safety must be considered in material selection.
- e. Such markings shall be provided and installed by the developer/applicant.
- f. All markings shall be approved by the Public Works Director prior to installation.
- g. All materials shall conform to the WSDOT/APWA Standard Specifications.
- h. All markings shall conform to the current MUTCD as adopted by the WSDOT.

34. Street Trees

- a. Existing native vegetation in the public right-of-way shall be preserved to the extent possible.
- b. The establishment of planting strips and planting of street trees is encouraged by the City, provided proximity to the street, ultimate size of the tree, utility lines, and other public safety and infrastructure protection issues are considered.
- c. Only trees listed in the City of Port Townsend Street Tree List (Exhibit 2, Appendix D) may be planted within City right-of-way, unless otherwise approved by the Public Works Department.
- d. At intersections and at vehicular access points, no plant material with a mature height greater than 30 inches shall be planted within the clear vision area, except where engineering standards indicate otherwise.
- e. No tree planting is permitted where the planting area between a curb and a detached sidewalk is less than four feet. In addition, a minimum planting area defined by two curbs, curb and fence, or sidewalk and fence must be four feet wide if street trees are to be planted.
- f. When the distance between the curb and detached sidewalk is less than eight feet, trees should be centered in the planting strip.
- g. Where the sidewalk is attached to the curb as a contiguous element, street trees should be planted between three and seven feet back from the walk.
- h. No tree is to be planted closer to the street than 30 inches back from the face of

the curb. The face of the curb is the street side of the curb, or as shown on the standard street sections.

- i. Larger maturing trees should generally be spaced 35 feet apart and smaller maturing trees 20 feet apart. The Public Works Director may require wider spacing if it is necessary for development of the tree or for safe use of the street or sidewalk. When space is limited or to achieve certain design effect, closer spacing may be considered.
- j. No tree shall be planted closer than five feet from any driveway or alley nor shall a tree or shrub be planted in such a manner that its eventual growth cannot be reasonably controlled so as to avert interference with or obstruction to any improvements installed for public benefit.
- k. Tree plantings made in a sidewalk must have a minimum of 10 square feet cutout area. The tree must be set back from the street a minimum of 30 inches from the face of the curb.
- l. No vegetation other than low-growing species that do not exceed a mature height of 20 feet may be planted under or within 10 feet of any overhead utility line.

35. Signalization

- a. All new traffic signals shall be provided with walk lights and bicycle activated signal detection.
- b. Signal controls shall meet ADA requirements.

36. Appurtenances

- a. An appurtenance is any fixed object located adjacent to the roadway and deemed to be a possible safety hazard.
- b. All appurtenances shall be located a minimum of three feet behind the face of the curb to the face of the object. Where no curb exists the distance from the edge of the travel way to the face of the object shall be at least six feet.
- c. All breakaway objects shall be located a minimum of two feet behind the face of curb to the face of the object. All objects having properties up to that of a four inch by four inch wooden post shall be considered breakaway.
- d. Appurtenances shall be located outside of the walkway area except when the walkway is widened around the appurtenance to the satisfaction of the Public Works Director.

37. Franchise Utilities

- a. All franchise utilities including power, cable T.V., and telephone shall be installed underground on all new streets. Overhead utilities will be allowed only when overhead service already exists along the frontage of the existing street.
- b. Utilities shall be placed underground at the expense of the utility with the franchise whenever improvements to arterials and collectors are made or whenever lines are being replaced or upgraded on any existing street with overhead service.
- c. Franchise utilities shall relocate existing facilities at their own expense when a

- conflict results between their facilities and public street improvements. The improvement work must be required by the city or be a component of a public works project in order for the relocation work to be the financial responsibility of the utility, otherwise all costs shall be the responsibility of the developer.
- d. When private utility lines are installed in the public right-of-way, the utility shall comply with the following:
 - i. A Street Development Permit must be submitted and approved prior to the start of any new installations.
 - ii. The location, depth and marking of utility lines shall be as shown on the Standard Details, or as otherwise approved by the City Engineer.
 - iii. The street frontage (including drainage, vegetation, driveways, and street surface) shall be returned to as good and safe condition as it was before the commencement of the work.
 - iv. Temporary erosion control practices described in Chapter 5 shall be followed. All disturbed areas shall be revegetated following installation and the utility is responsible for the establishment of the vegetation.
 - v. A franchisee shall leave all streets, avenues, highways or public places in as good and safe condition in all respects as they were before the commencement of such work by a franchisee and in accordance with all city regulations and street standards. The public works director shall have final approval of the condition of such streets and public places after completion of construction. A franchisee's responsibility under this section shall extend for 12 months after completion of construction, installation, maintenance or repair of such facilities for inadequate restoration of streets that was not apparent at the time of any such final approval.
 - e. When telecommunications and fiber optics lines are installed, the City may require that a spare conduit be installed for use by the City to connect public facilities at no expense to the City and as a condition of City approval for installation of the service lines, provided this is allowed under the franchise agreement.

38. Warranty/Guarantee

- a. All work done under a Street Development Permit shall be guaranteed for one year as to materials and workmanship.

**TABLE 6-1
MINIMUM STREET STANDARD SUMMARY**

Transportation Facility Type	Minimum Right-of-Way (3)	Pavement Width	Radius of Curvature of Centerline	Maximum Allowable Grade	Curb Radius (2)	Curb and Gutter (1)	Parking	Walkway(s)	Bikeway(s)	Standard Detail
Principal Arterial (SR20) - see Gateway Plan	80-100 feet	36-60 feet	300 feet	8%	35 feet	Required	none	Required both sides except for the Bluff Corridor	required both sides (except in Bluff Corridor bikeway shared with ferry holding lane)	
Minor Arterial	80 feet	34 feet	200 feet	8%	28 feet	Required	No on street parking except, required in multi-use zones	Required both sides:	Required both sides	T-3 through T-5A
Collector - Major	60 to 80 feet	32 feet	150 feet	10%	25 feet	Required	on street parking except multi-use zones	both sides	Required both sides	
Collector - Neighborhood or Minor	60 feet	32 feet	150 feet	10%	15 feet	Asphalt rolled curb or concrete	none	Required one side min.	Required both sides	T-7
Scenic Collector/Arterial	60 feet	22 feet	150 feet	12%	25 feet	Asphalt wedge curb	none	Required one side and separated from the roadway	not required	T-6
Local Access- High Density	50 feet	26 feet (4)		12%	15 feet	Required	on-street	Required on both sides		T-8
Local Access- Minimum Standard	50	16 feet		12%	10 feet	concrete rolled curb	none on paved surface	none	none	T-9

(1) Alternative pavement edge may be considered depending on topography, local drainage, adjacent land uses, and width of right-of-way.

(2) For an intersection with the next lowest street hierarchy. May be modified depending on bus and truck traffic in the route.

(3) For guidance. Right-of-way width depends on project traffic volume, turn lanes, intersection needs, stormwater control methods, topography, and other features that dictate the needed street-section width.

(4) Pinch points, bulbs, pocket parking, etc., may be used to reduce pavement width.

**TABLE 6-2
LOCAL ACCESS (NEIGHBORHOOD) STREET STANDARD SUMMARY**

Local Access Street Type	General Location	Housing density (units/acre)	Lot Frontage - At average Buildout	Typical Paved Width	Curb Radius	Curb and Gutter - Typical (1)	Parking	Walkways		Standard Detail
High Intensity	New subdivisions developed at greater than 6 units per acre	6+ per acre	less than 75 feet	26 feet (2)		Concrete		?		
Medium Intensity	Typical buildout of existing platted lots	3 to 5 per acre	70 feet to 130 feet	20 feet		asphalt				
Low intensity	- Houses/lots on one side of road. - One to two houses per block	1 to 2 per acre	130 to 200 feet	18 feet		crushed gravel shoulder allowed, depending on slope and drainage				
Side street, connectors, rural lanes	Access roads, side streets	- no direct frontage - no current houses		16 feet		shoulder with drainage swale or ditch				

(1) Edge requirement and ditch/swale designs depends on topography, soils, and other site conditions.

(2) Pinch points, bulbs, pocket parking, etc., may be used to reduce pavement width.

CHAPTER 6 - APPENDIX A

Exhibit #	Standard Detail #	Title
1	T - 1	Typical Utility Location
2	T - 2	Pavement Sections
3	T - 3	Arterial and Collector Mixed Use Zones
4	T - 4	Arterial Collector Multi-Family and Commercial
Areas		
5	T - 5A	Arterial and Major Collector RI & RII Zones
6	T - 5B	Major Collector RI & RII Zones
7	T - 6	Scenic Collector
8	T - 7	Minor (Neighborhood) Collector
9	T - 8	Local Access Street High Intensity/Density
10	T - 9	Local Access Street Minimum Standard
11	T - 11	Sight Obstruction
12	T - 12	Street Tree Spacing and Location Requirements
13	T - 13	Cement Concrete Curb and Gutter, Type A-1"
14	T - 14	Rolled Curb Detail
15	T - 15	Sidewalk Installation
16	T - 16	Curb Ramps
17	T - 17	Driveway Installation
18	T - 19	Residential Driveway Approach with Culvert
19	T - 20	Driveway Location
20	T - 21	Bicycle Lane Striping General Guide
21	T - 22	Survey Monument
22	T - 23	Survey Control Monument
23	T - 24	Survey Control Monument 3" Brass Disc
24	T - 25	Joint Utility Trench Section for Secondary/Service
Lines		
25	T - 26	Traffic Sign Installation
26	T - 27	Traffic Control Plan



City of Port Townsend - Public Works Department

Standard Detail

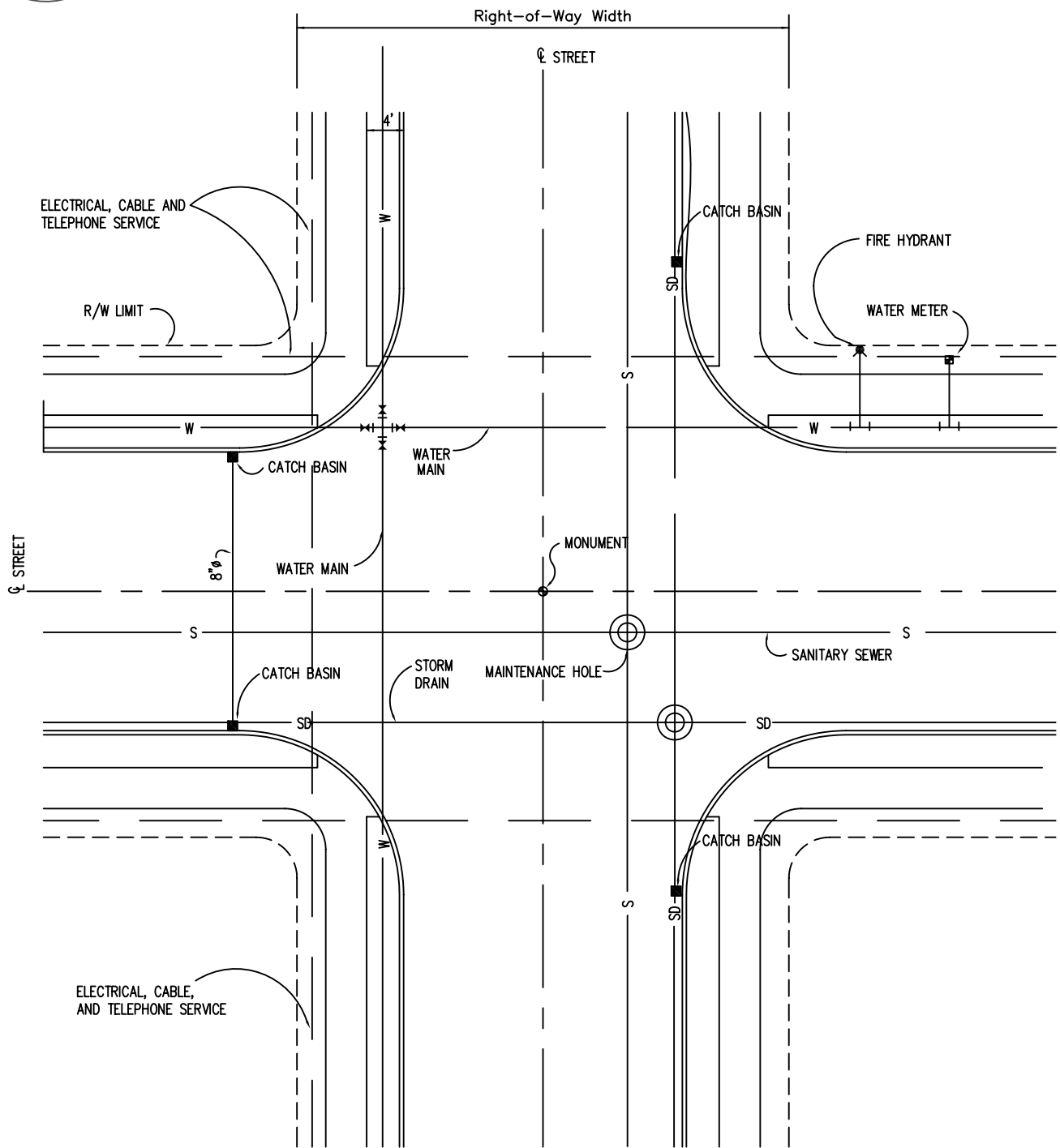

NOTE:

THIS DRAWING IS INTENDED ONLY TO ILLUSTRATE GENERAL LOCATION OF UTILITIES WITHIN THE RIGHT OF WAY.

Date: April 1997

Approved By:

File: E:\eng_std\standard\transpo

No.	Date	Revision	By	Apvd

Typical Utility
Location

Detail: T-1



City of Port Townsend - Public Works Department

Standard Detail

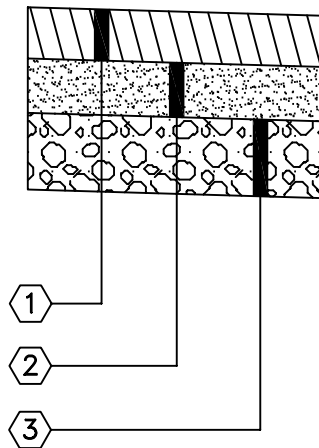

	MINOR ARTERIAL	COLLECTOR	LOCAL ACCESS
① ASPHALT CLASS B	4.0"	3.0"	2.0"
② CRUSHED SURFACING TOP COURSE	4.0"	2.0"	2.0"
③ GRAVEL BASE (1)	10.0"	10.0"	8.0"

NOTES:

(1) BASE MAY NEED TO BE INCREASED DEPENDING ON SUITABILITY OF NATIVE MATERIAL.

Date: April 1997	No.	Date	Revision	By	Apvd	Pavement Sections
Approved By:						
File: E:\eng_std\standard\transpo						Detail: T-2



City of Port Townsend - Public Works Department

Standard Detail

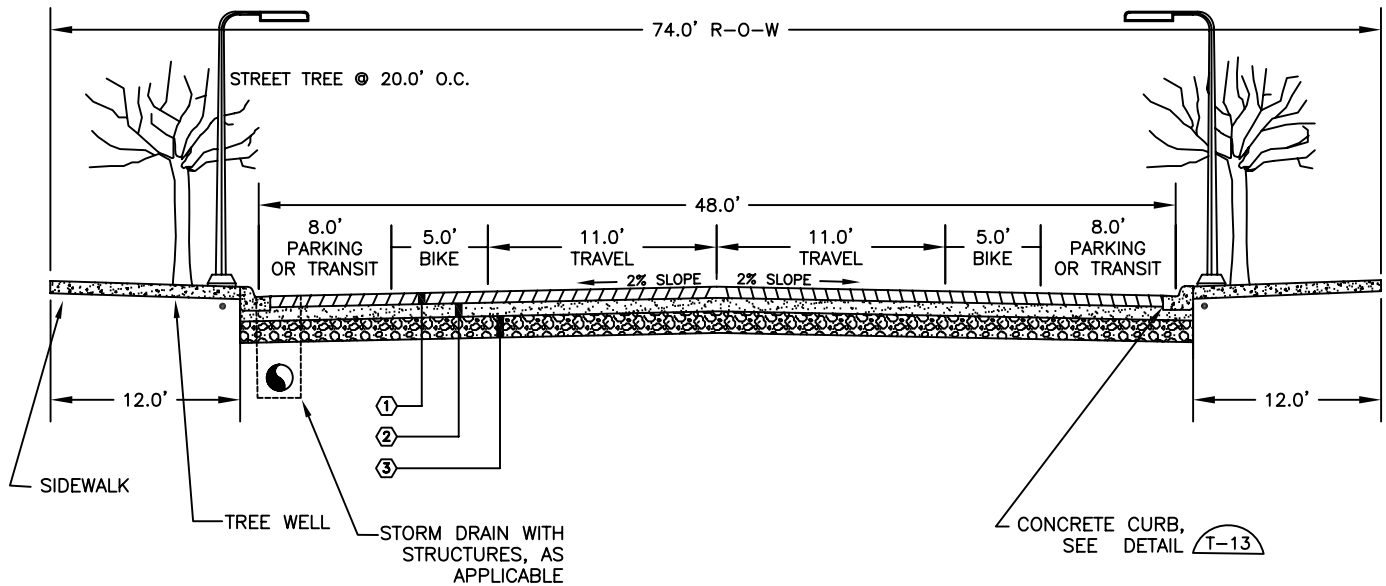

ROADWAY SECTION

MIXED USE ZONES (C-I/MU, C-II/MU)

OR OTHER AREAS WHERE ON-STREET PARKING IS ALLOWED OR REQUIRED.

Date: April 1997	No.	Date	Revision	By	Apvd	<h3 style="margin: 0;">Arterial and Collector</h3> <p style="margin: 0;">Mixed Use Zones</p> <h2 style="margin: 0;">Detail: T-3</h2>
Approved By:						
File: E:\eng_std\standard\transpo						



City of Port Townsend - Public Works Department

Standard Detail

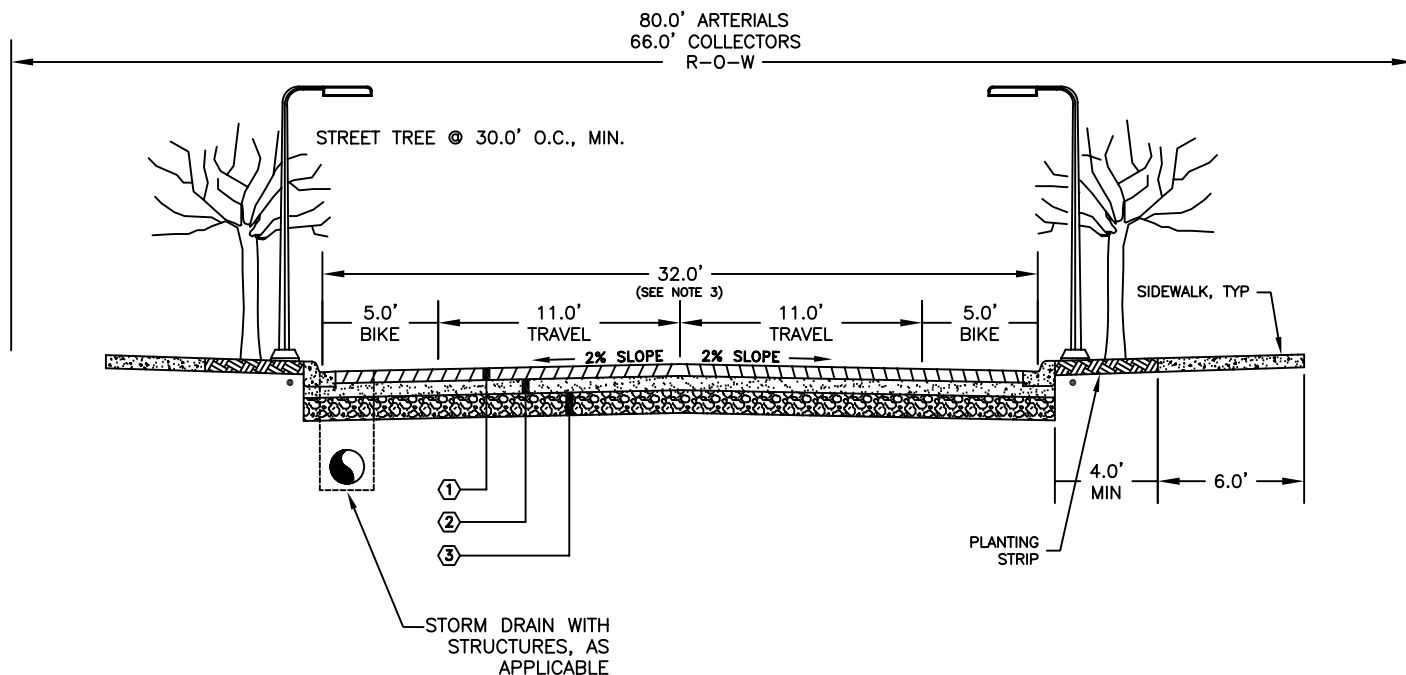

ROADWAY SECTION

RIII, RIV, COMMERCIAL AND MARINE/MANUFACTURING AREAS

NOTE:

- (1) POWER AND UTILITIES SHALL BE UNDERGROUND.
- (2) PROVIDE STREET LIGHTS IN ACCORDANCE WITH SPECIFICATIONS.
- (3) TURN LANES, TRANSIT PULLOUTS, AND OTHER IMPROVEMENTS MAY BE REQUIRED DEPENDING ON THE ADJACENT DEVELOPMENT, TRAFFIC VOLUME, AND INTERSECTION NEEDS.
- (4) USE DETAIL T-3 WHERE ON-STREET PARKING IS TO BE PROVIDED.

Date: April 1997	No.	Date	Revision	By	Apvd	<h3 style="margin: 0;">Arterial and Collector</h3> <p style="margin: 0;">Multi-Family and Commercial Areas</p> <h2 style="margin: 0;">Detail: T-4</h2>
Approved By:						
File: E:\eng_std\standard\transpo						



City of Port Townsend - Public Works Department

Standard Detail

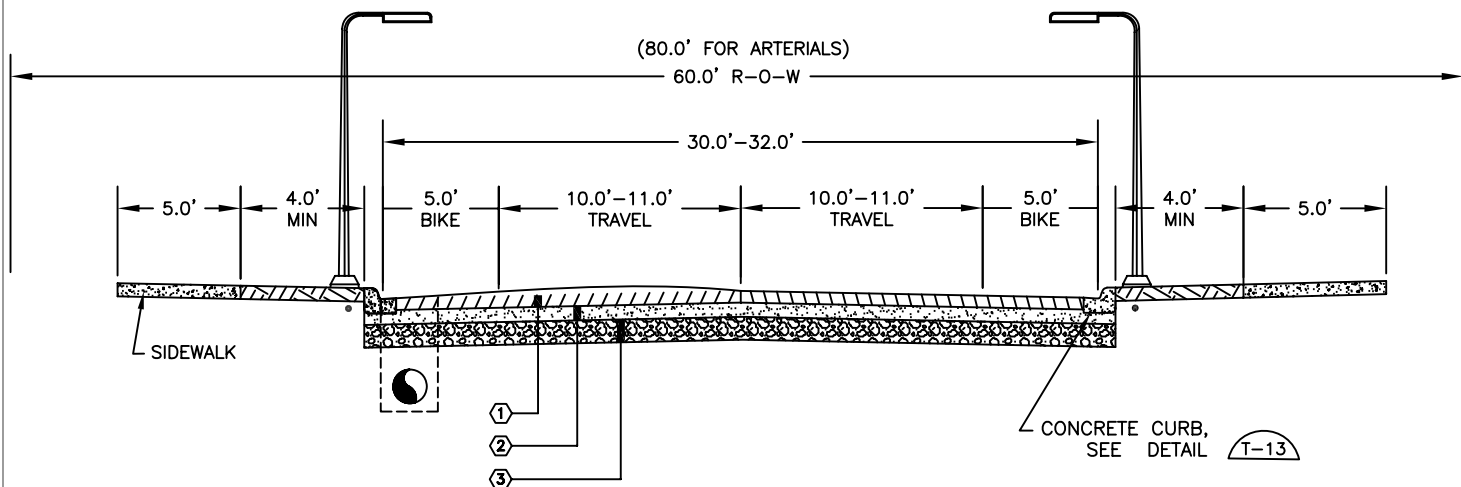

ALTERNATIVE A

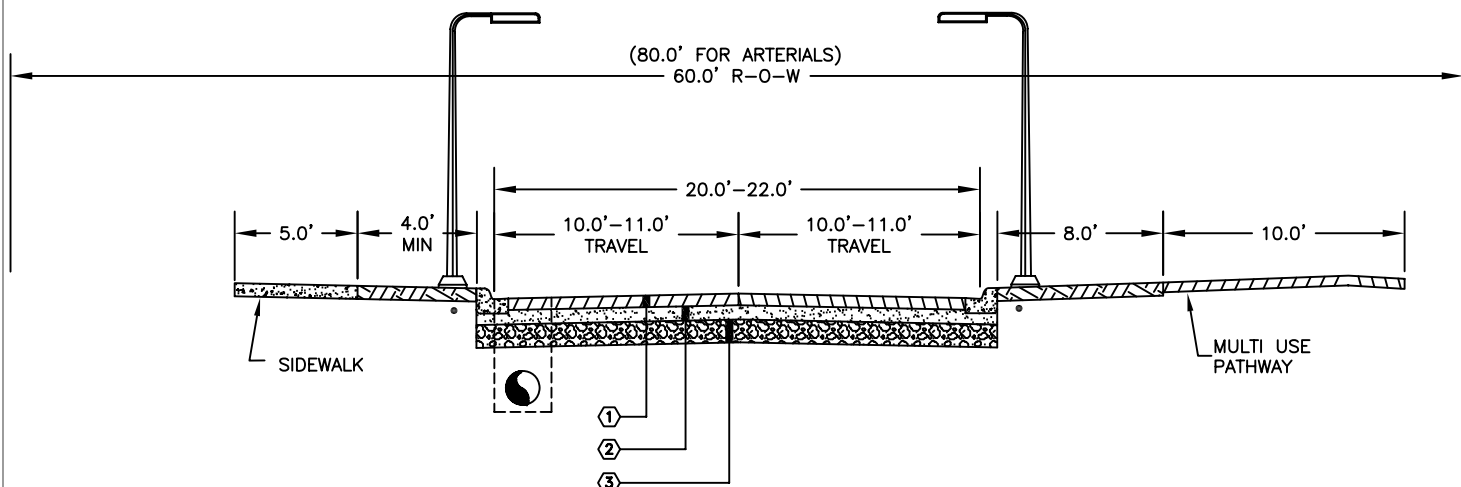

ALTERNATIVE B

TRAVEL LANES:

ARTERIALS 11.0' TRAVEL LANE
 COLLECTORS 10.0' TRAVEL LANE

NOTE:

- 1) POWER AND UTILITIES SHALL BE UNDERGROUND.
- 2) STREET LIGHTS PER SPECIFICATION.
- 3) ASPHALT WEDGE CURB OR SHOULDER WITH DRAINAGE MAY BE USED DEPENDING ON RIGHT-OF-WAY WIDTH, STORM DRAINAGE DESIGN, OR OTHER FACTORS AS APPROVED BY THE P.W.D.

Date: April 1997	No.	Date	Revision	By	Apvd	Arterial and Major Collector RI & RII Zones Detail: T-5A
Approved By:						
File: E:\eng_std\standard\transpo						



City of Port Townsend - Public Works Department

Standard Detail

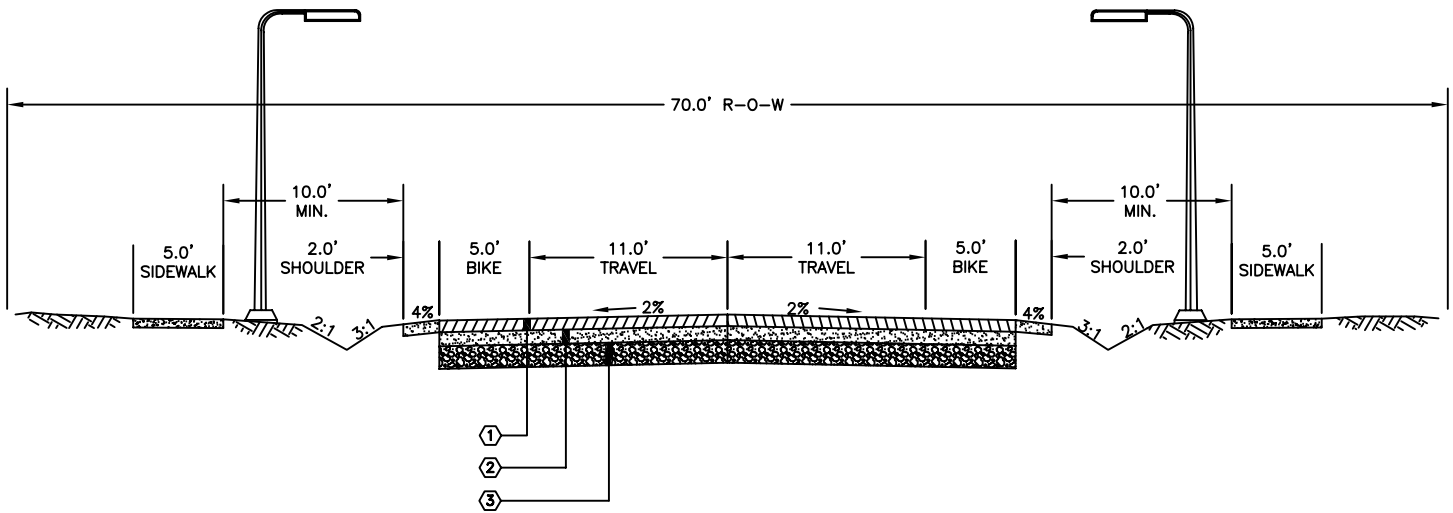

ALTERNATIVE C

3.) LOCATE SIDEWALK TO PRESERVE EXISTING VEGETATION.

Date: April 1997	No.	Date	Revision	By	Apvd	<p style="font-size: 1.2em; margin: 0;">Major Collector</p> <p style="margin: 0;">RI & RII Zones</p> <hr/> <p style="font-size: 1.2em; margin: 0;">Detail: T-5B</p>
Approved By:						
File: E:\eng_std\standard\transpo						



City of Port Townsend - Public Works Department

Standard Detail

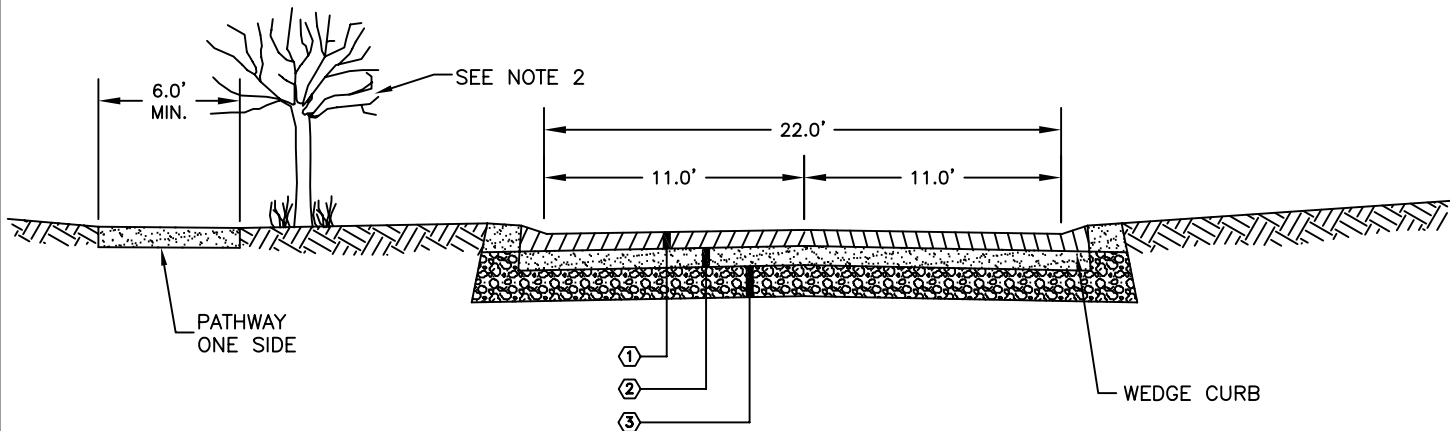

ALTERNATIVE A

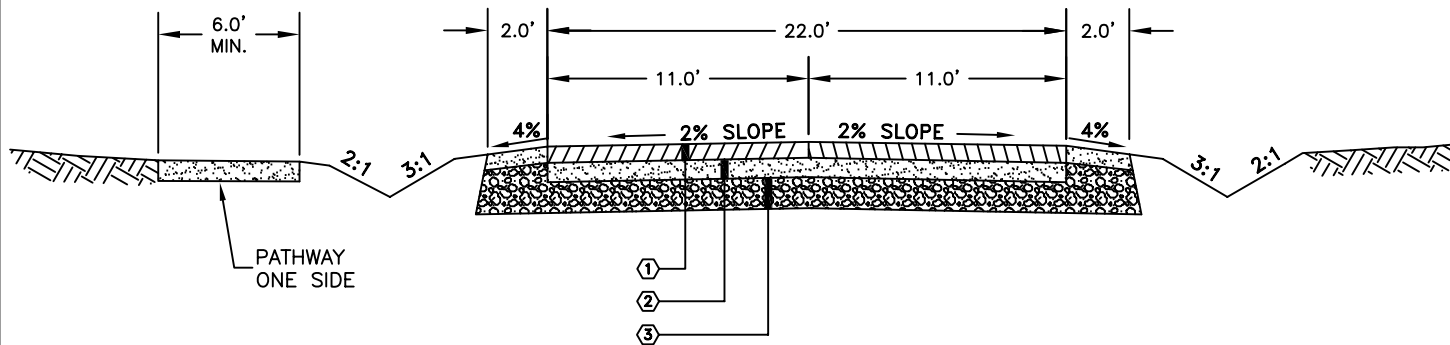

ALTERNATIVE B

NOTE:

- 1) ROAD EDGE: DITCH OR ASPHALT CURB, DEPENDING ON DRAINAGE REQUIREMENTS, TOPOGRAPHY, VEGETATION, ETC.
- 2) PRESERVE EXISTING ROADSIDE VEGETATION AND TREE CANOPY TO MAXIMUM EXTENT POSSIBLE.
- 3) LOCATE PATHWAY AS TO PRESERVE VEGETATION.

Date: April 1997	No.	Date	Revision	By	Apvd	Scenic Collector Detail: T-6
Approved By:						
File: E:\eng_std\standard\transpo						



City of Port Townsend - Public Works Department

Standard Detail

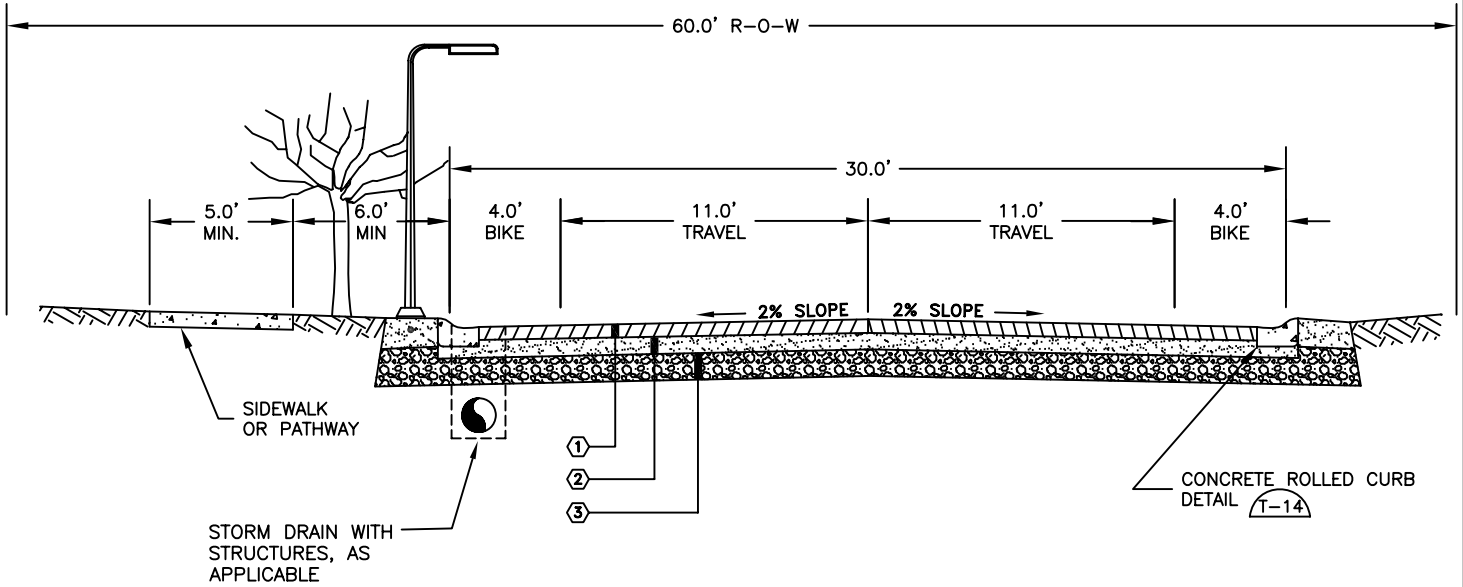

ALTERNATIVE A

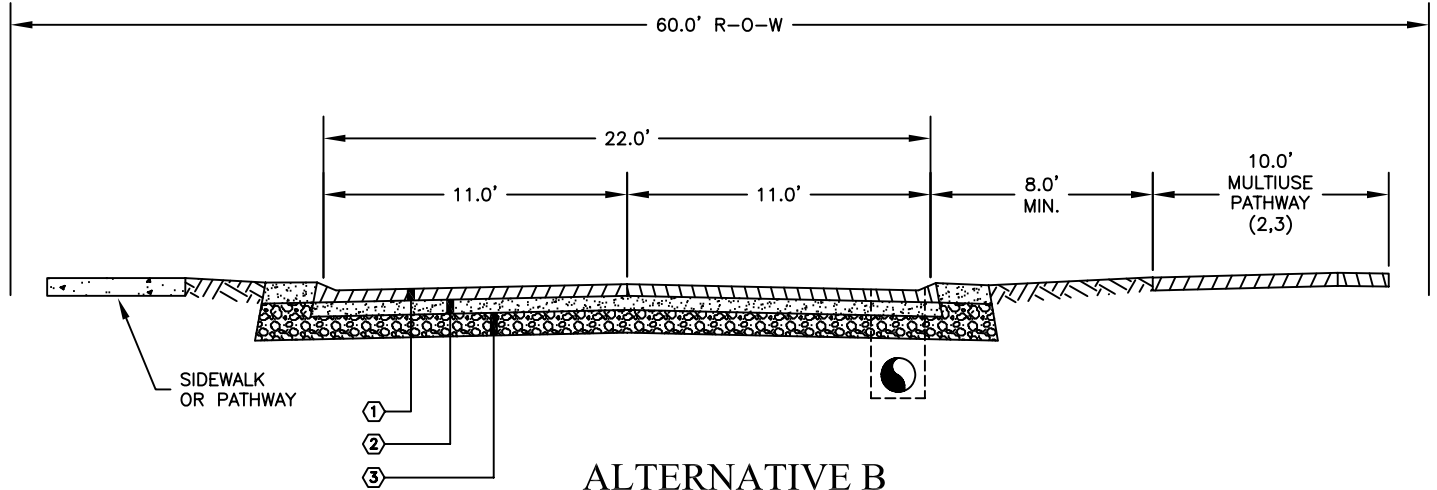

ALTERNATIVE B

NOTES:

- (1) BIKE LANES MAY BE ELIMINATED WHEN A MULTI-USE PATHWAY IS NEARBY AND PERFORMS A SIMILAR FUNCTION.
- (2) PATHWAY MAY NOT BE NECESSARILY ADJACENT TO THE ROADWAY, LOCATE PATHWAY TO PRESERVE VEGETATION.

Date: April 1997

Approved By:

File: E:\eng_std\standard\transpo

No.	Date	Revision	By	Apvd

Minor (Neighborhood) Collector

Detail: T-7



City of Port Townsend - Public Works Department

Standard Detail

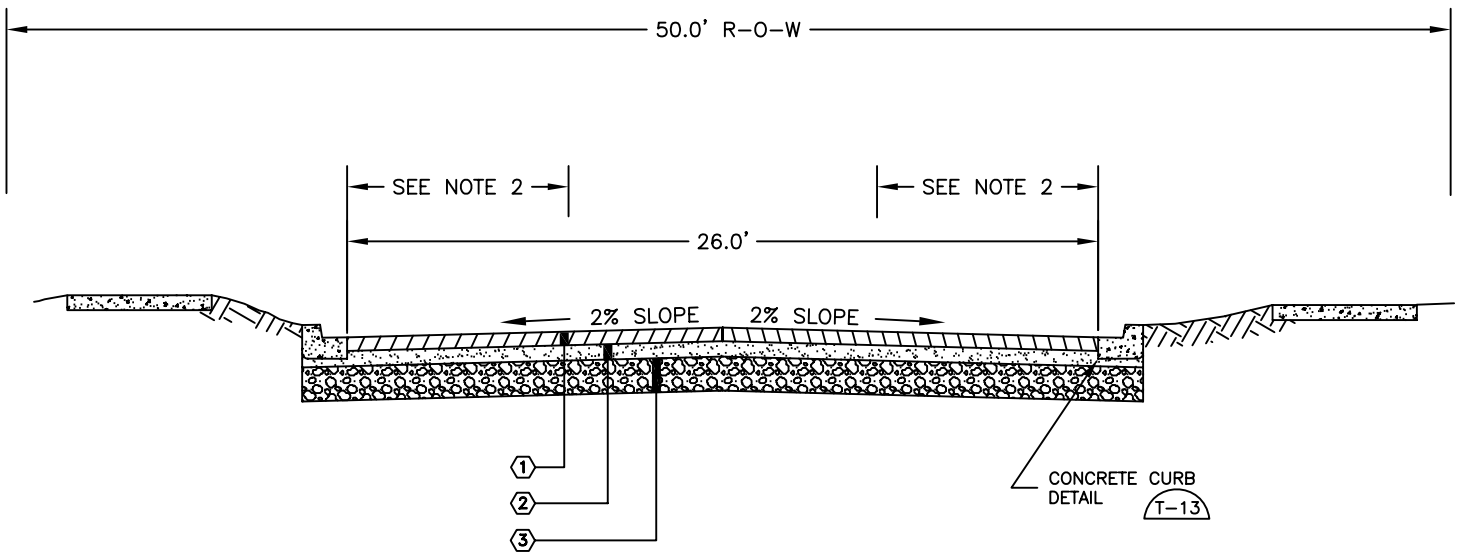

NOTE:

- (1) MAY BE REQUIRED OR SUBMITTED FOR CONSIDERATION FOR ONE OR MORE OF THE FOLLOWING SITUATIONS
 - NON-GRID STREET PATTERN OF > 20 HOMES SERVED.
 - STREETS WITH NO DRIVEWAYS OR ON-SITE PARKING.
 - DEVELOPED LOT FRONTAGE LESS THAN 60 FEET
- (2) PROVIDE TRAFFIC CALMING SUCH AS, PINCH POINTS, BULBS, POCKET PARKING OR TRAFFIC CIRCLES AT INTERSECTIONS.
 - SEE EXAMPLES IN APPENDIX 6E

Date: April 1997	No.	Date	Revision	By	Apvd	<h3 style="margin: 0;">Local Access Street</h3> <h3 style="margin: 0;">High Intensity / Density</h3>
Approved By:						Detail: T-8
File: E:\eng_std\standard\transpo						



City of Port Townsend - Public Works Department

Standard Detail

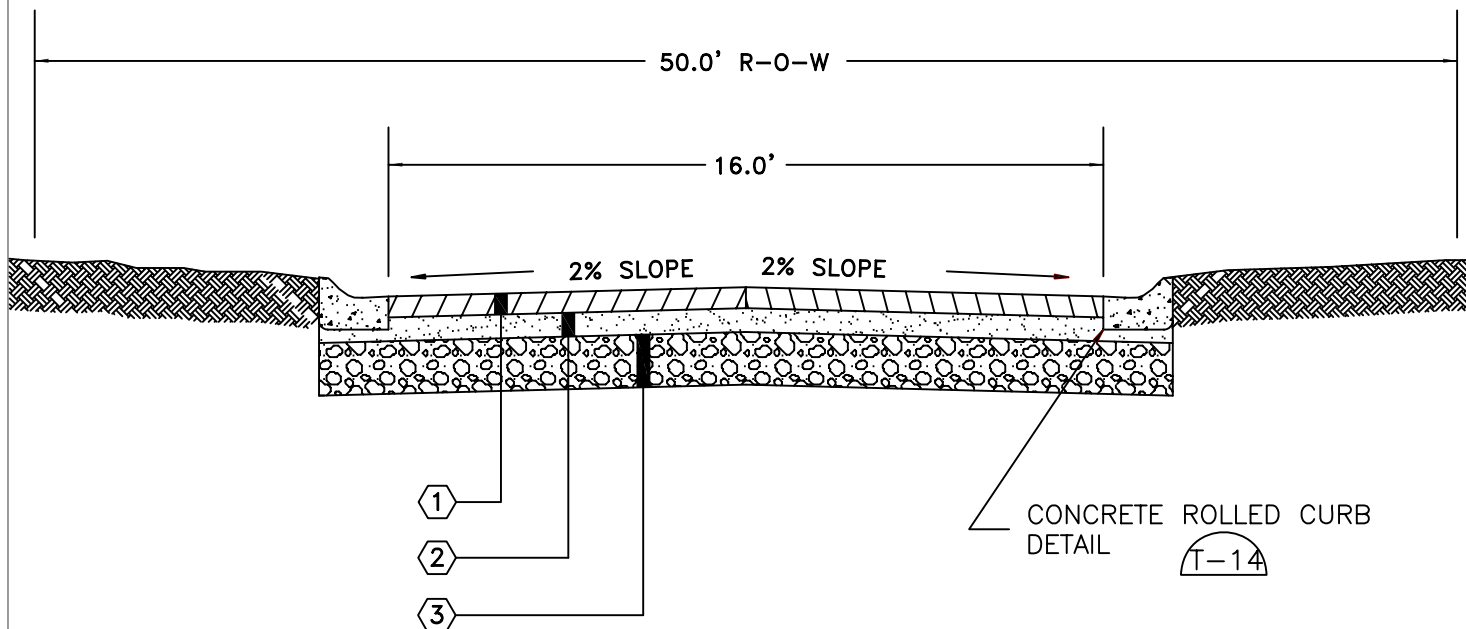

Notes:

(1) Use for:

- *Grid or modified grid street patterns
- *Where driveways and on-site parking are provided

(2) Traffic circles and diverters are encouraged to breakup the grid.

(3) Alternative curb options and drainage design may be considered depending on specific site conditions.

(4) Design may need to be modified for steep slopes.

Date: 7/18/95

City of Port Townsend
181 Quincy Street, Suite 301
Port Townsend, WA 98368

No.	Date	Revision	By	Apvd.

Local Access Street
Minimum Standard

Detail: T-9



City of Port Townsend - Public Works Department

Standard Detail

STOP OR YIELD CONTROLLED INTERSECTIONS

EXAMPLE: MAJOR STREET SPEED LIMIT = 25 M.P.H

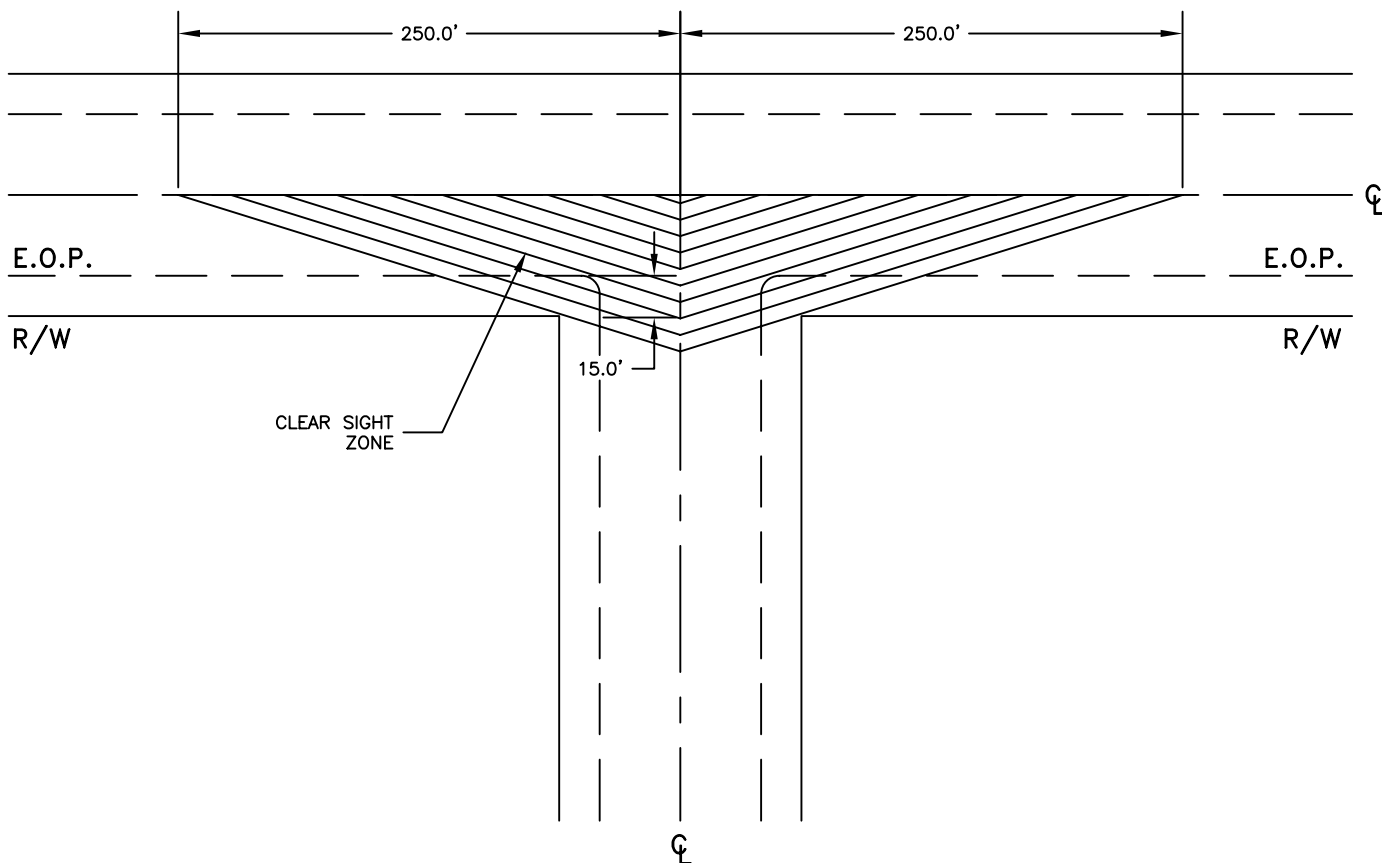

Date: April 1997

No.	Date	Revision	By	Apvd

Sight Obstruction

Approved By:

File: E:\eng_std\standard\transpo

Detail: T-11



City of Port Townsend - Public Works Department

Standard Detail

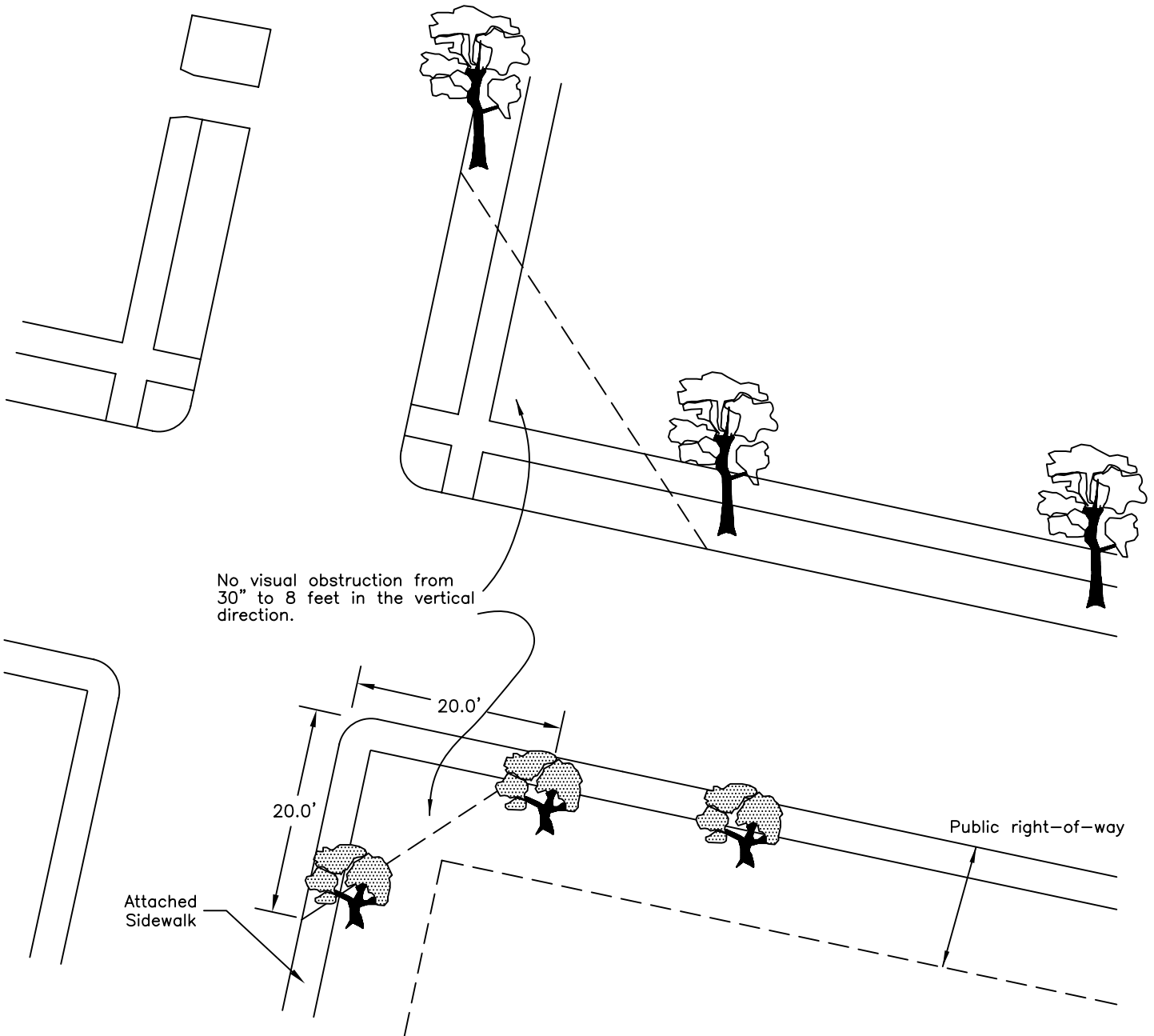

Date: April 1997

Approved By:

File: E:\eng_std\standard\transpo

No.	Date	Revision	By	Apvd

Street Tree Spacing
and Location Requirements

Detail:

T-12



City of Port Townsend - Public Works Department

Standard Detail

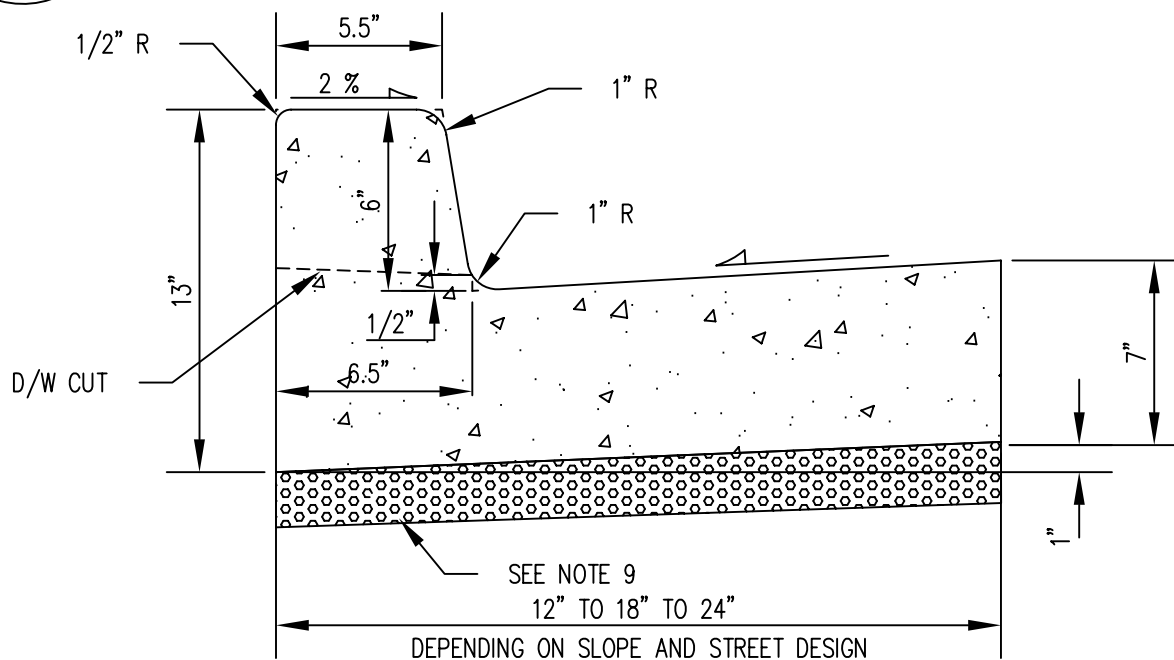

TYPICAL SECTION

NOTES

- 1 FORMS SHALL BE TRUE TO LINE AND GRADE AND SECURELY STAKED.
- 2 DUMMY JOINTS SHALL BE PLACED ON 15 FOOT CENTERS. DUMMY JOINTS SHALL BE 1/2" x 1-1/2".
- 3 THRU JOINTS SHALL BE PLACED ADJACENT TO CATCH BASINS, INLETS AND AT POINTS OF TANGENCY ON STREETS, ALLEY AND DRIVEWAY RETURNS. MAXIMUM SPACING SHALL BE 30 FT. PRE-MOLDED JOINT FILLER SHALL BE 1/2" WIDE AND CONFORM TO AASHTO DESIGN M213.
- 4 ALL JOINTS SHALL BE CLEAN AND EDGED.
- 5 CONCRETE SHALL BE CEMENT CONCRETE, CLASS 3000.
- 6 STEEL FORMS ONLY SHALL BE USED ON TANGENT SECTIONS. WOOD FORMS MAY BE USED ON CURVED SECTIONS.
- 7 FINISH SHALL BE LIGHT BROOM FINISH.
- 8 THE FINISHED CURB SHALL BE SPRAYED WITH A TRANSPARENT CURING COMPOUND AND COVERED BY WATERPROOF PAPER OR PLASTIC MEMBRANE IN THE EVENT OF RAIN OR OTHER UNSUITABLE WEATHER. CURING TIME SHALL BE A MINIMUM OF 72 HOURS.
- 9 ALL CURB AND GUTTER SHALL BE PLACED ON A MINIMUM OF 2" OF CRUSHED SURFACING TOP COURSE.
- 10 DUMMY JOINT 1/2" x 1-1/2" BETWEEN A-1 CURB AND GUTTER AND THE SIDEWALK.

Date: April 1996	No.	Date	Revision	By	Apvd	Cement Concrete Curb and Gutter, Type "A-1" Detail: T-13
Approved By:						
File: E:\eng_std\standard\transpo						



City of Port Townsend - Public Works Department

Standard Detail

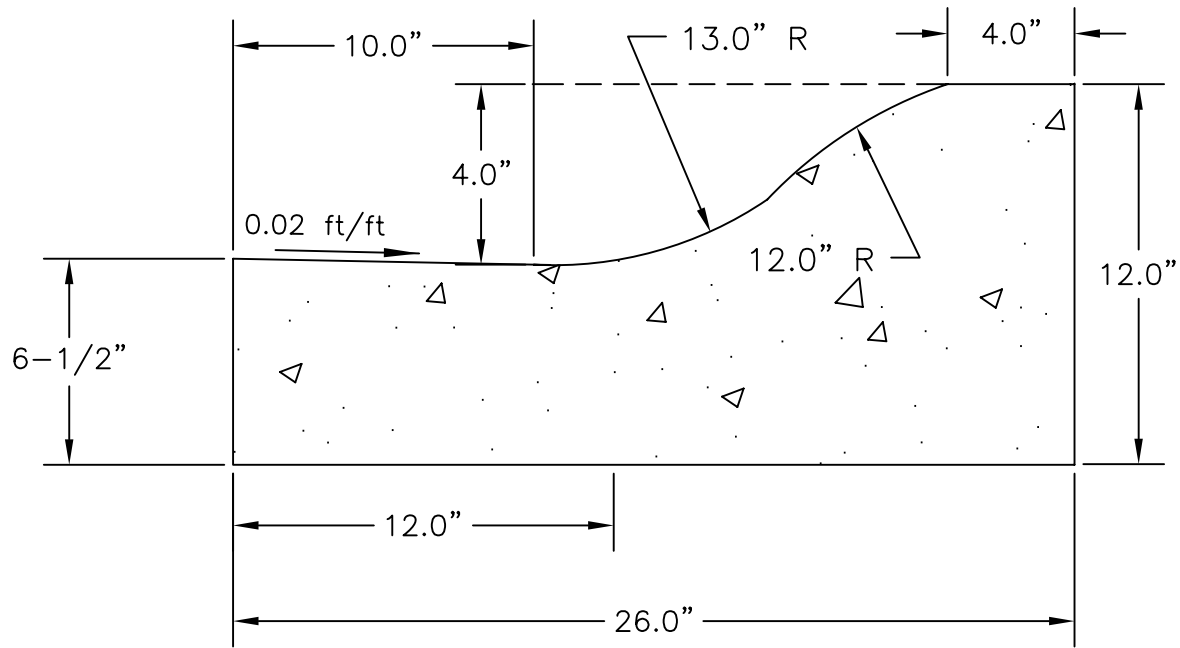

ROLLED CURB AND GUTTER

NOTES:

- 1) CONCRETE SHALL BE WSDOT CLASS 3000.

Date: April 1997	No.	Date	Revision	By	Apvd	Rolloed Curb Detail
Approved By:						
File: E:\eng_std\standard\transpo						Detail: T-14



City of Port Townsend - Public Works Department

Standard Detail

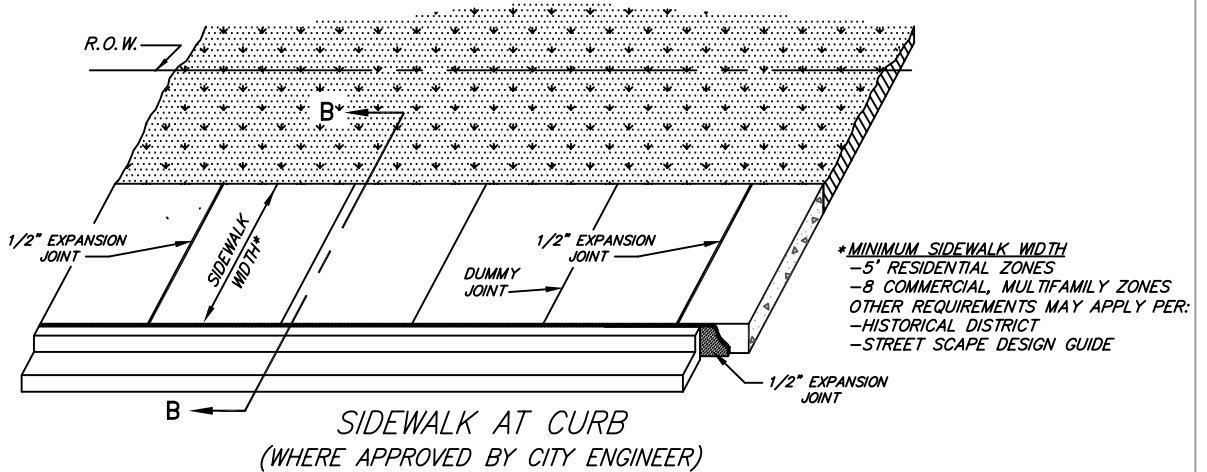
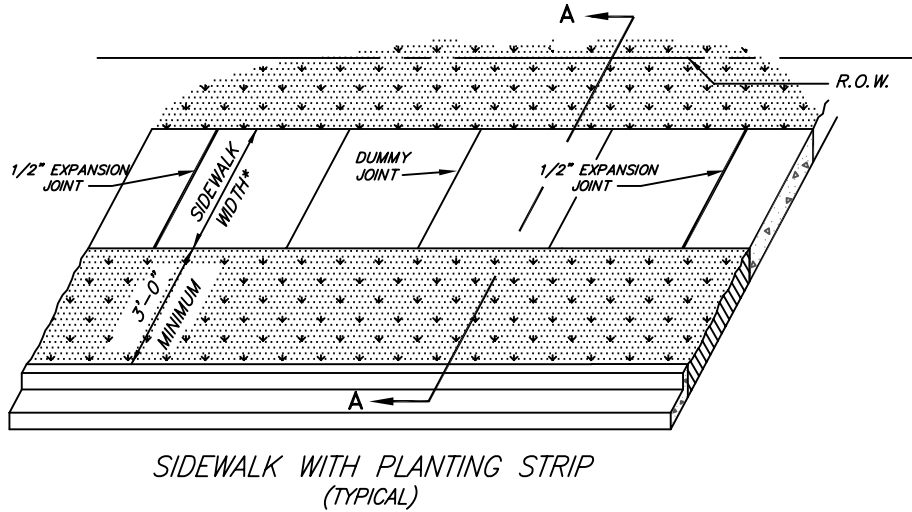

***MINIMUM SIDEWALK WIDTH**
 -5' RESIDENTIAL ZONES
 -8' COMMERCIAL, MULTIFAMILY ZONES
 OTHER REQUIREMENTS MAY APPLY PER:
 -HISTORICAL DISTRICT
 -STREET SCAPE DESIGN GUIDE

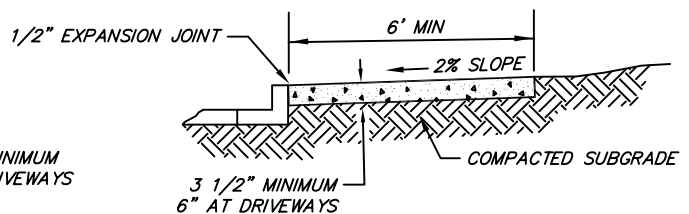
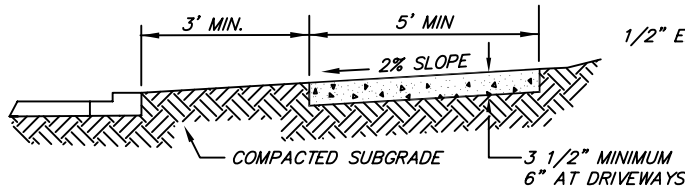

NOTES:

1. EXPANSION JOINTS SHALL BE ASPHALT IMPREGNATED JOINT MATERIAL.
2. EXPANSION JOINTS SHALL BE 1/2" THICK AND AT 20'-0" INTERVALS.
3. DUMMY JOINTS SHALL BE AT 5'-0" INTERVALS.
4. ALL UTILITY POLES, METER BOXES, ETC. IN SIDEWALK AREA SHALL HAVE 1/2" JOINT MATERIAL (FULL DEPTH) PLACED AROUND THEM BEFORE PLACING CONCRETE.
5. ALL JOINTS SHALL BE CLEAN AND EDGED.
6. NO EXPOSED AGGREGATE WORK SHALL BE DONE.
7. DRIVEWAY AND SIDEWALK SHALL BE SEPARATED FROM OTHER CONCRETE WORK USING EXPANSION MATERIAL.
8. CURB AND GUTTER SHALL NOT BE POURED INTEGRAL WITH DRIVEWAY.
9. CONCRETE SHALL BE CLASS 3000.

CALL FOR FORM INSPECTION BY CITY PRIOR TO POURING CONCRETE.

ALL WORK AND MATERIALS TO BE IN ACCORDANCE WITH CURRENT STANDARD SPECIFICATIONS FOR ROAD, BRIDGE AND MUNICIPAL CONSTRUCTION, WASHINGTON STATE DEPARTMENT OF TRANSPORTATION, AMERICAN PUBLIC WORKS ASSOCIATION.

Date: April 1997	No.	Date	Revision	By	Apvd	<h3>Sidewalk Installation</h3>
Approved By:						
File: E:\eng_std\standard\transpo						



City of Port Townsend - Public Works Department

Standard Detail

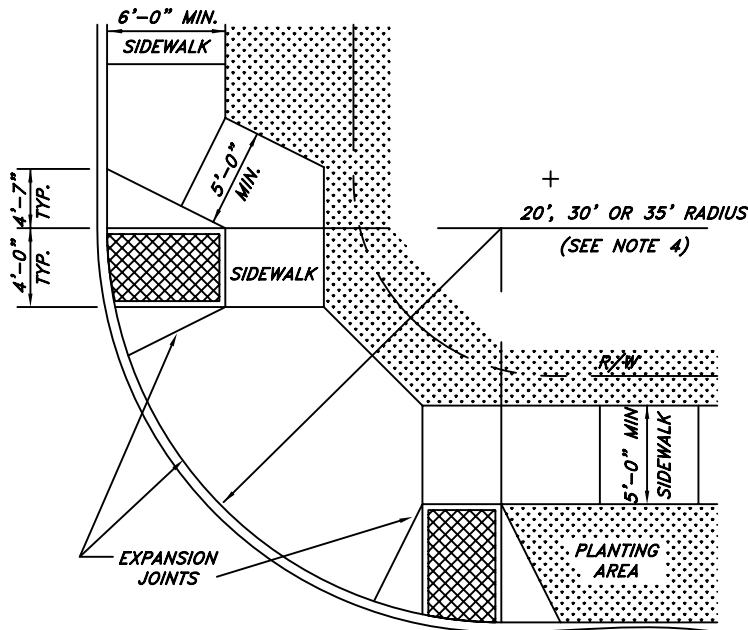

CORNER CURB RAMPS

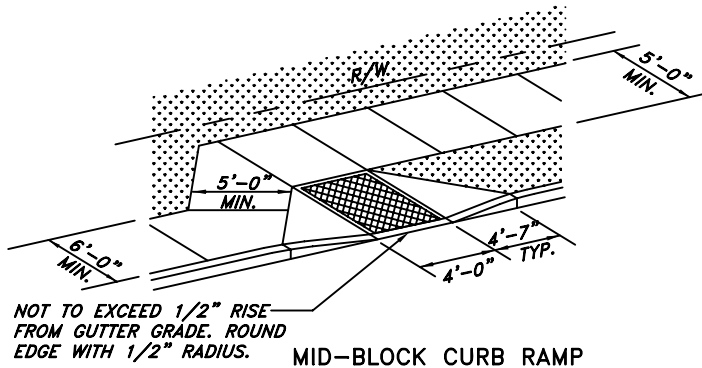

MID-BLOCK CURB RAMP

NOTES:

1. TEXTURING OF CENTER RAMP REQUIRED USING METAL GRID PLACED IN WET CONCRETE AND THEN REMOVED TO LEAVE RIDGED SURFACE PATTERN. PATTERN NOT TO EXCEED 1/2" GRID.
2. CURB RAMP CEMENT CONCRETE SHALL BE CLASS 3000, 3-1/2" THICK MINIMUM.
3. EXPANSION JOINTS SHALL BE 1/4" THICK, FULL DEPTH, ASPHALT IMPREGNATED JOINT MATERIAL.
4. STEEP STREET GRADES AND/OR CURVE RETURN RADII OF LESS THAN 20 FEET OR GREATER THAN 35 FEET, REQUIRE SPECIAL DESIGN CURB RAMPS TO BE APPROVED BY CITY ENGINEER.
5. SIDEWALK CROSS SLOPES NOT TO EXCEED 2%. CURB RAMP SLOPE TO BE 1:12 OR FLATTER.
6. SIDEWALK WIDTHS SHOWN ARE FOR RESIDENTIAL AREAS.

ALL WORK AND MATERIALS TO BE IN ACCORDANCE WITH CURRENT STANDARD SPECIFICATIONS FOR ROAD, BRIDGE AND MUNICIPAL CONSTRUCTION, WASHINGTON STATE DEPARTMENT OF TRANSPORTATION, AMERICAN PUBLIC WORKS ASSOCIATION.

CALL FOR FORM INSPECTION BY CITY PRIOR TO POURING CONCRETE.

Date: April 1997	No.	Date	Revision	By	Apvd	Curb Ramps
Approved By:						
File: E:\eng_std\standard\transpo						



City of Port Townsend - Public Works Department

Standard Detail

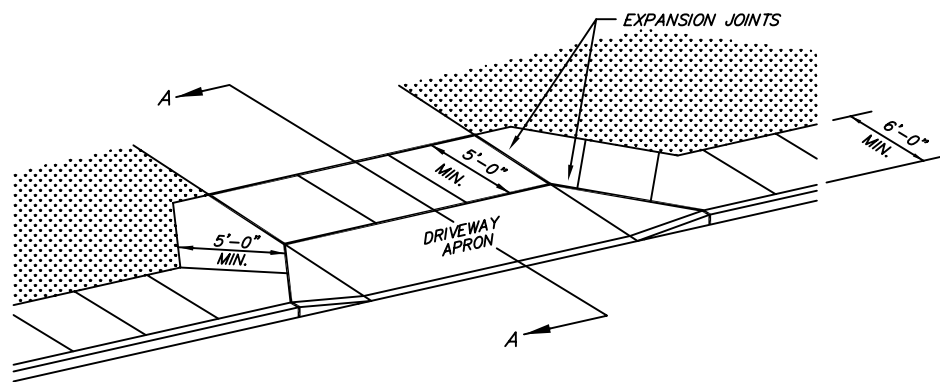
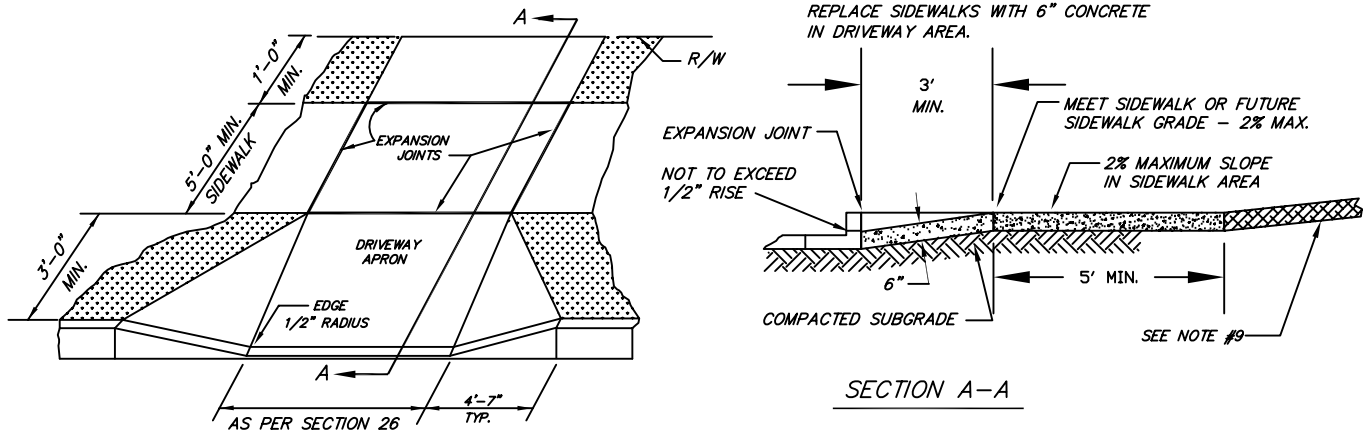

DRIVEWAY BYPASS REQUIRED WHEN
SIDEWALK IS AT CURB

NOTES:

1. DRIVEWAY LOCATION TO BE APPROVED BY CITY ENGINEER.
2. WHEN SIDEWALK IS NOT PRESENT, DRIVEWAY APPROACH SHALL BE CONSTRUCTED TO MEET FUTURE SIDEWALK GRADE.
3. SIDEWALK CROSS SLOPE SHALL NOT EXCEED 2% IN DRIVEWAY AND BYPASS AREAS.
4. DRIVEWAY APRON AND SIDEWALK SHALL BE CONCRETE AND SEPARATED FROM OTHER CONCRETE WORK USING EXPANSION JOINTS.
5. SIDEWALKS, CURB AND GUTTER PER CITY STANDARD PLANS.
6. EXPOSED AGGREGATE WORK OR SPECIAL SURFACE TREATMENT NOT ALLOWED IN RIGHT-OF-WAY WITHOUT APPROVAL.
7. LONGITUDINAL DUMMY JOINTS, 1/8" THICK AND 1" DEEP, SHALL BE AT INTERVALS NOT TO EXCEED 15 FEET AND BE EQUALLY SPACED IN DRIVEWAY APRONS.
8. CONCRETE SHALL BE CLASS 3000.
9. DRIVEWAY PAVING MATERIALS, OTHER THAN CONCRETE, MAY BE USED BETWEEN THE SIDEWALK AND THE R/W WITH CITY ENGINEER APPROVAL.
10. EXPANSION JOINTS SHALL BE 1/4" THICK, FULL DEPTH, ASPHALT IMPREGNATED JOINT MATERIAL.
11. SIDEWALK WIDTHS SHOWN ARE FOR RESIDENTIAL AREAS.

ALL WORK AND MATERIALS TO BE IN ACCORDANCE WITH CURRENT STANDARD SPECIFICATIONS FOR ROAD, BRIDGE AND MUNICIPAL CONSTRUCTION, WASHINGTON STATE DEPARTMENT OF TRANSPORTATION, AMERICAN PUBLIC WORKS ASSOCIATION.

CALL FOR FORM INSPECTION BY CITY PRIOR TO POURING CONCRETE.

Date: April 1997	No.	Date	Revision	By	Apvd	Driveway Installation
Approved By:						
File: E:\eng_std\standard\transpo						



City of Port Townsend - Public Works Department

Standard Detail

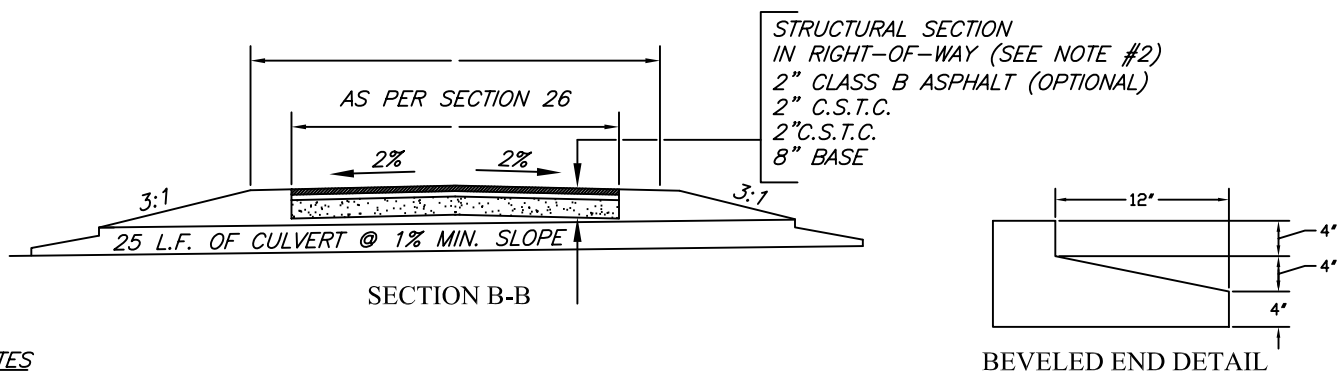
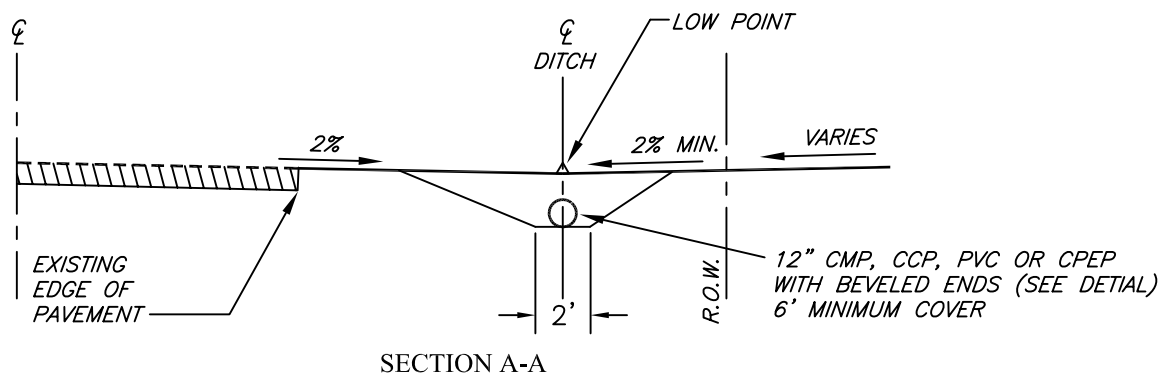
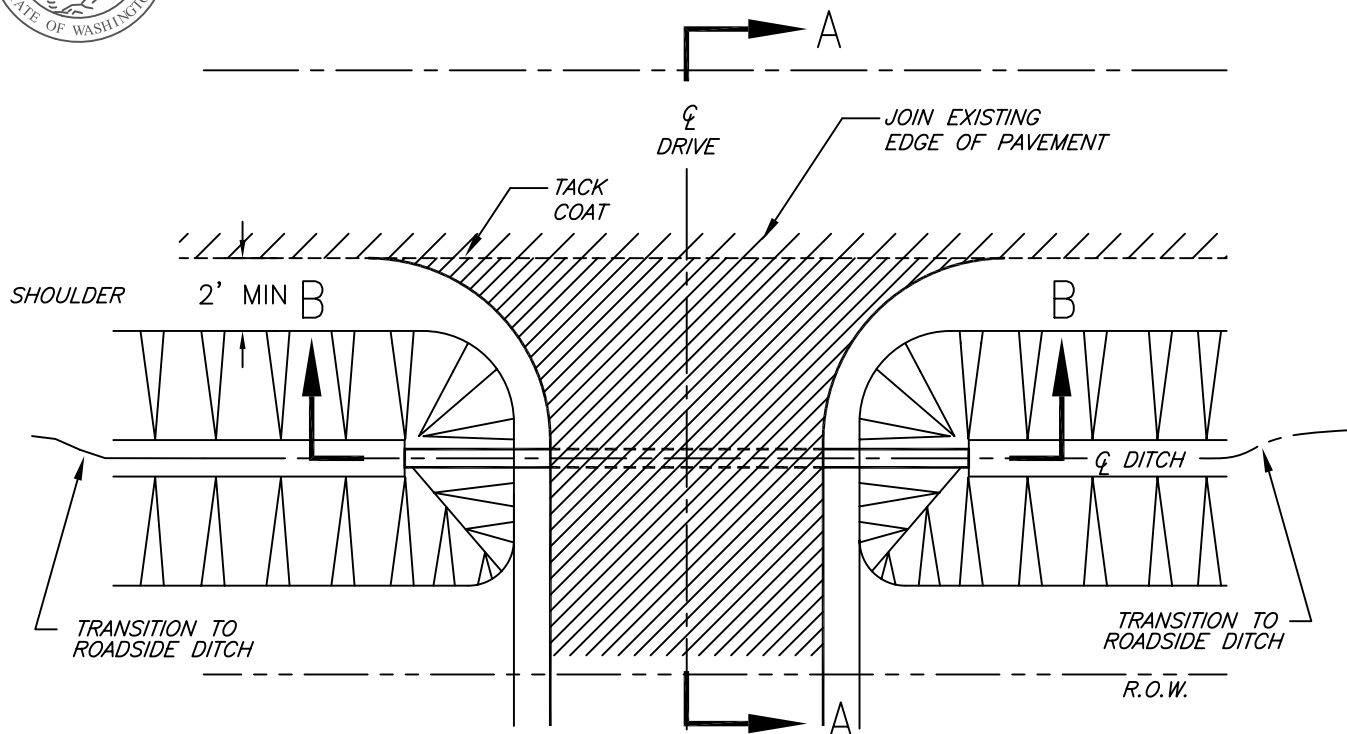

BEVELED END DETAIL

NOTES

1. STREET DEVELOPMENT PERMIT REQUIRED.
2. 6" CONCRETE (PLAIN FINISH) MAY BE SUBSTITUTED.

Date: April 1997	No.	Date	Revision	By	Apvd	<h3 style="margin: 0;">Residential Driveway Approach with Culvert</h3> <p style="margin: 0;">Detail: T-19</p>
Approved By:						
File: E:\eng_std\standard\transpo						



City of Port Townsend - Public Works Department

Standard Detail

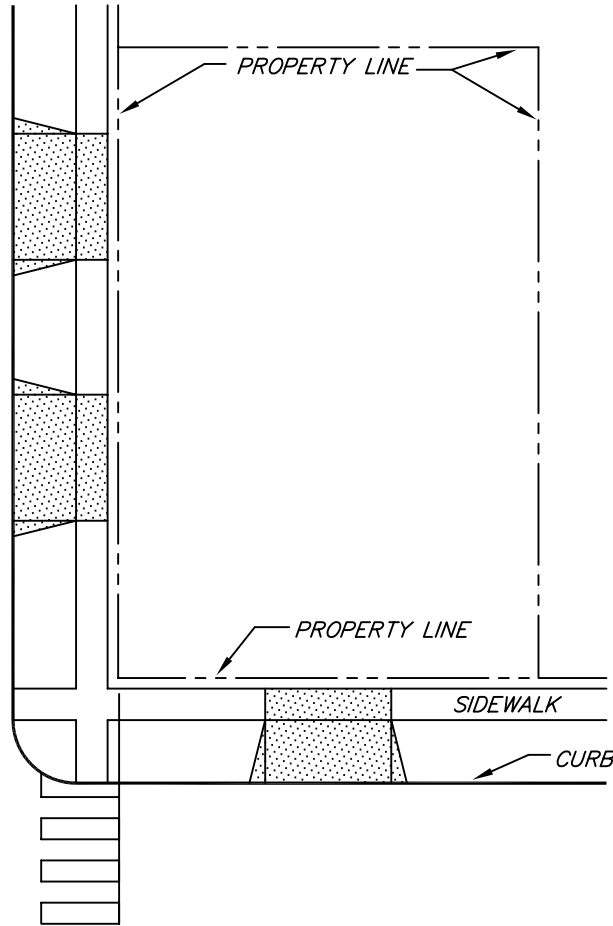

NOTES:

- ① ALLEY OR NON-ARTERIAL ACCESS IS ENCOURAGED WHERE POSSIBLE.
- ② DRIVEWAY SHALL BE LOCATED TO AVOID CONFLICT WITH POWER POLES, STREET LIGHTS, FIRE HYDRANTS OR SITUATIONS WHICH RESULT IN UNSAFE CONDITIONS.
- ③ DRIVEWAY WIDTHS AS SPECIFIED IN SECTION 26.
- ⑤ WHERE TWO OR MORE ADJOINING DRIVEWAYS ARE APPROVED FOR THE SAME PROPERTY, A FULL CURB HEIGHT SEPARATION BETWEEN EACH DRIVEWAY, OF NOT LESS THAN 15 FEET AT THE CURB, MUST BE PROVIDED.
- ⑥ DRIVEWAY APRONS SHALL NOT EXTEND INTO THE STREET FURTHER THAN THE FACE OF THE CURB.
- ⑦ DRIVEWAY SHALL BE LOCATED AWAY FROM INTERSECTION WHERE POSSIBLE AND IN ACCORDANCE WITH SECTION 26.
- ⑧ COMMERCIAL AND INDUSTRIAL DRIVEWAY LOCATIONS REQUIRE CITY ENGINEER APPROVAL AND SHALL BE SHOWN ON SITE PLAN WITH REQUIRED PARKING LAYOUT.
- ⑨ DRIVEWAYS THAT ARE ABANDONED OR RELOCATED SHALL BE REMOVED AND CURBING REPLACED TO FULL HEIGHT.

CALL FOR FORM INSPECTION BY CITY PRIOR TO POURING CONCRETE.

ALL WORK AND MATERIALS TO BE IN ACCORDANCE WITH CURRENT STANDARD SPECIFICATIONS FOR ROAD, BRIDGE AND MUNICIPAL CONSTRUCTION, WASHINGTON STATE DEPARTMENT OF TRANSPORTATION, AMERICAN PUBLIC WORKS ASSOCIATION.

Date: April 1997	No.	Date	Revision	By	Apvd	Driveway Location
Approved By:						
File: E:\eng_std\standard\transpo						Detail: T-20



City of Port Townsend - Public Works Department

Standard Detail

TYPICAL INTERSECTION STRIPING DIMENSIONS
FOR STREETS AND ON-STREET PARKING

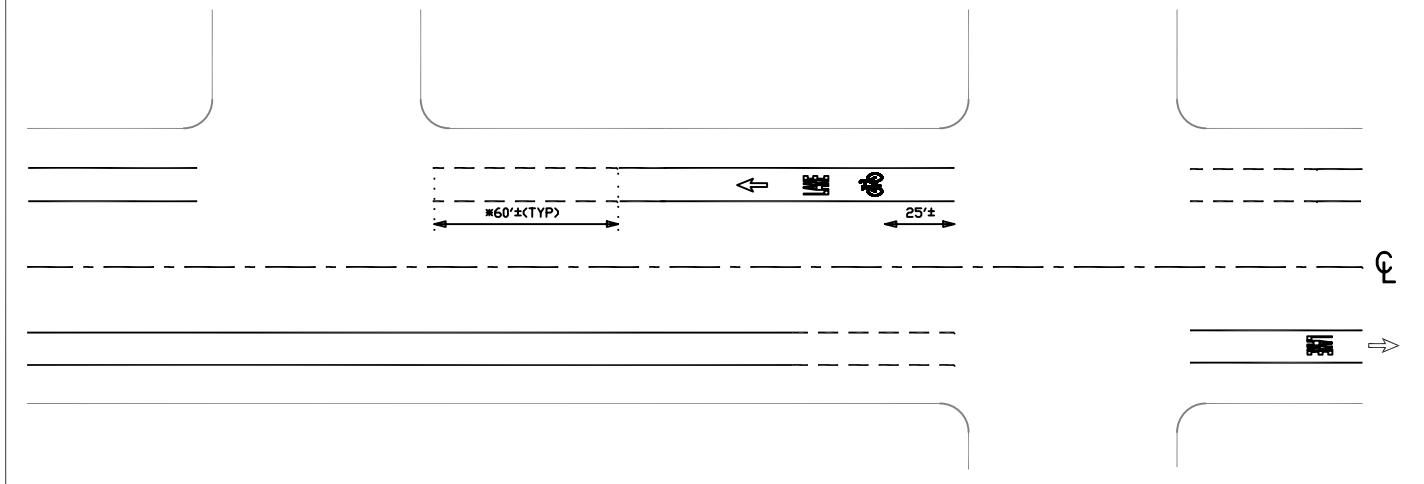

NOTES:

ALL STRIPING 4" WHITE

** VARIES, DEPENDING ON VOLUME OF TURNING TRAFFIC

STRIPING DETAILS FOR DASHED LINES

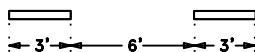

PREFERRED BIKE LANE SYMBOL,
AS PERMITTED BY 1993 WASHDOT MUTCD

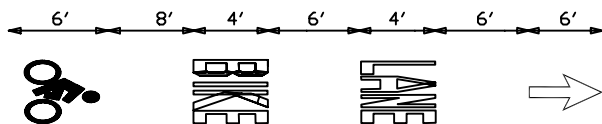

NOTES:

STRIPING IS SHOWN FOR A GENERAL GUIDANCE ONLY
FOR STREET AND INTERSECTION STRIPING FOR BIKE LANES

Date: April 1997

Approved By:

File: E:\eng_std\standard\transpo

No.	Date	Revision	By	Apvd

Bicycle Lane Striping
General Guide

Detail: T-21



City of Port Townsend - Public Works Department

Standard Detail

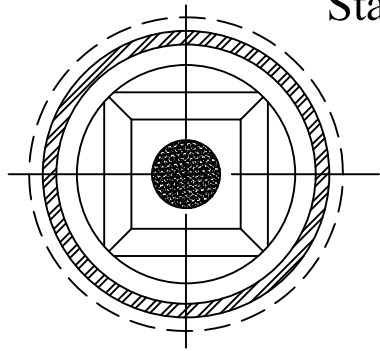

PLAN
COVER REMOVED

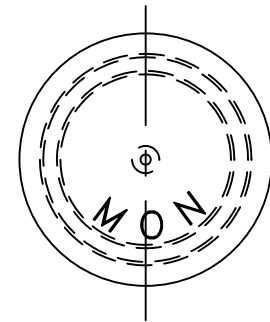

COVER PLAN

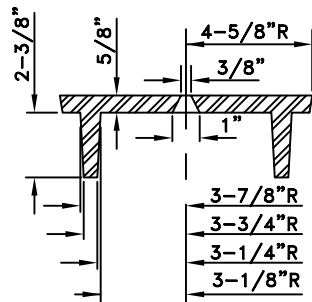

COVER SECTION

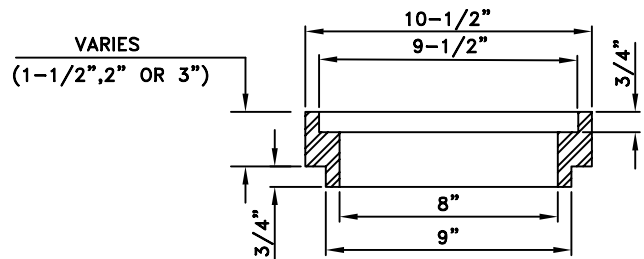

EXTENSION SECTION

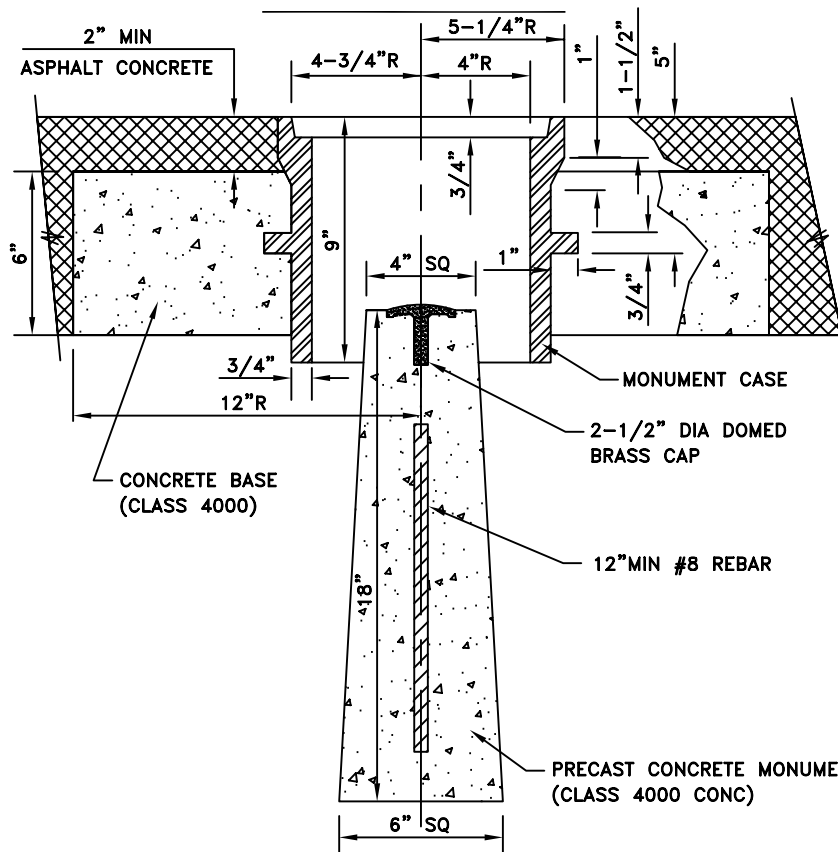

SECTION

NOTES

1. MONUMENTS IN NON PAVED AREAS SHALL BE 3" ABOVE GRADE.
2. ALL MONUMENTS SHALL BE PRECAST CONC WITH REBAR AND 2-1/2" DIA BRASS CAP.
3. MONUMENT CASE AND RISER SECTION SHALL BE CAST IRON PER ASTM-A48, CLASS 30, WITH BITUMINOUS COATING.
4. COVER SHALL BE DUCTILE IRON PER ASTM-A536, GRADE 80-55-06. WITH BITUMINOUS COATING.
5. LEGEND ON COVER SHALL BE 1/8" RAISED INTEGRALLY CAST LETTERS 1" HIGH WITH A MIN FACE WIDTH OF 3/16".

Date: April 1997

Approved By:

File: E:\eng_std\standard\transpo

No.	Date	Revision	By	Apvd

Survey Monument

Detail:

T-22



City of Port Townsend - Public Works Department

Standard Detail

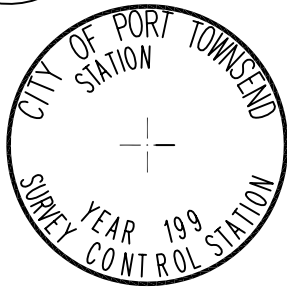

NOTES

THIS MONUMENT SHALL BE USED ONLY FOR CONTROL MONUMENTATION SURVEYS AT LOCATIONS AS APPROVED BY THE CITY SURVEYOR.

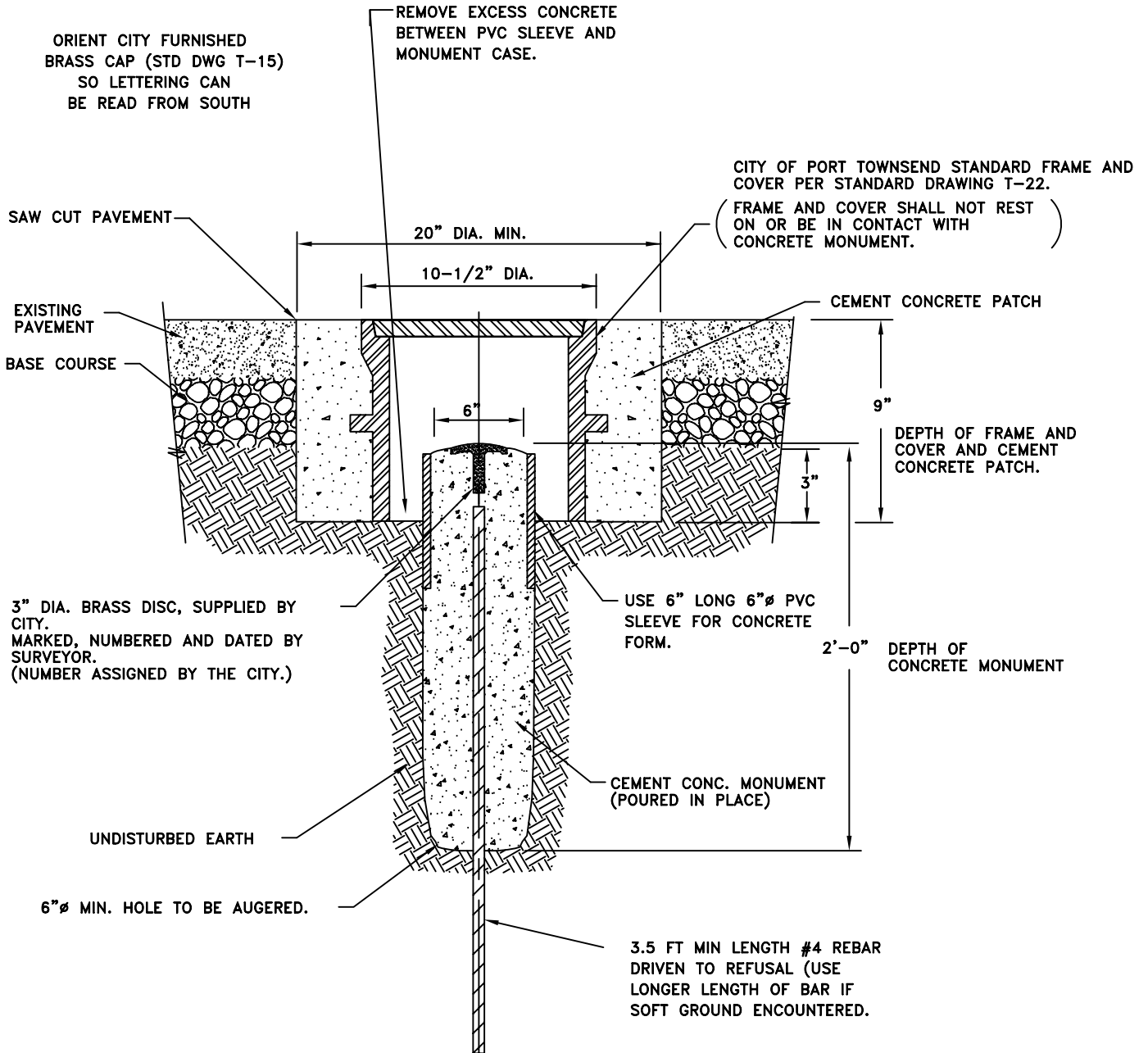

Date: April 1997

No.	Date	Revision	By	Apvd

Survey Control Monument

Approved By:

File: E:\eng_std\standard\transpo

Detail:

T-23



City of Port Townsend - Public Works Department

Standard Detail

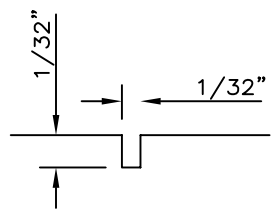
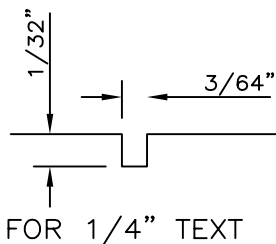

GROOVE DETAIL

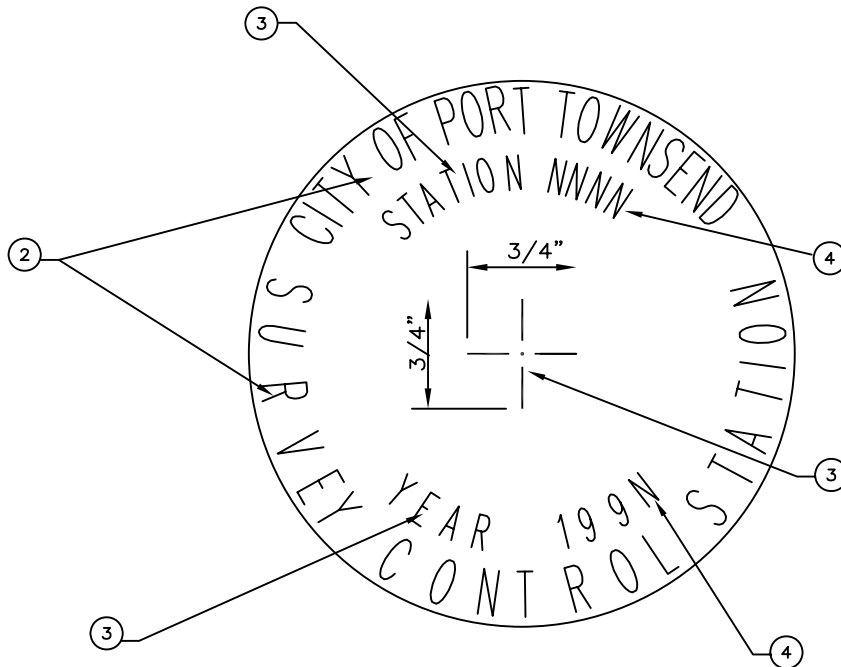

PLAN

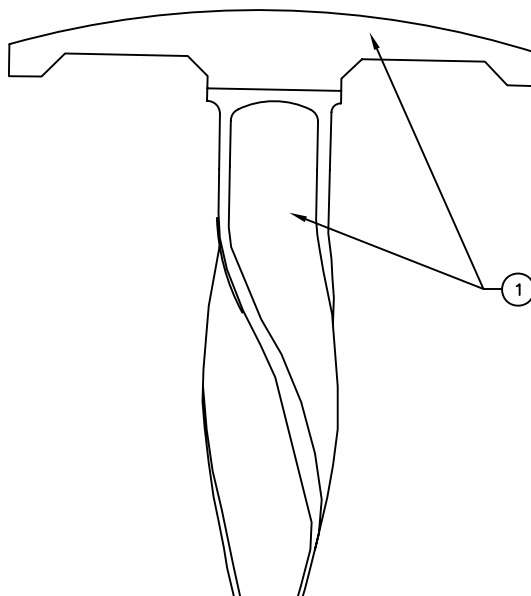

ELEVATION

NOTES:

- ① DIMENSIONS OF CASTING BASE & CAP PER WSDOT/APWA STANDARD PLAN H-6.
- ② GROOVE FOR 1/4" HIGH CAST LETTERING ON CAP SHALL BE 1/32 IN DEEP BY 3/64 IN WIDE.
- ③ GROOVE FOR 3/16" HIGH CAST LETTERING AND LINES ON CAP SHALL BE 1/32 IN DEEP BY 1/32 IN WIDE.
- ④ FIELD STAMPED LETTERS AND NUMBERS SHALL BE OF SUFFICIENT DEPTH AND WIDTH SO AS TO BE CLEARLY READABLE AND SHALL BE A MIN. OF 3/16 IN. HIGH.
- ⑤ THIS BRASS DISC SHALL ONLY BE USED FOR CONTROL MONUMENTATION PER STD DWG T-14 AND AS DIRECTED BY THE CITY SURVEYOR. BRASS DISC AND STATION NO SHALL BE SUPPLIED BY CITY SURVEYER.

Date: April 1997	No.	Date	Revision	By	Apvd	Survey Control Monument 3" Brass Disc Detail: T-24
Approved By:						
File: E:\eng_std\standard\transpo						



City of Port Townsend - Public Works Department

Standard Detail

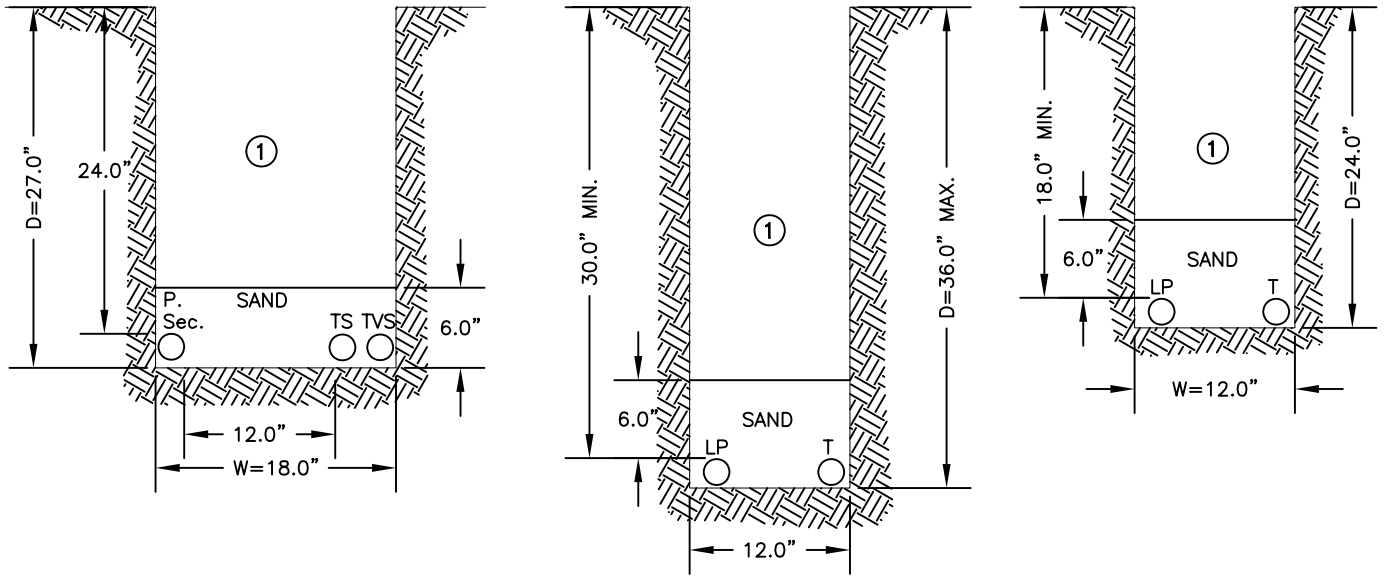

DIRECT BURIED CONDUIT

① =SELECTED OR IMPORTED BACKFILL PER APWA SECTION 61-6

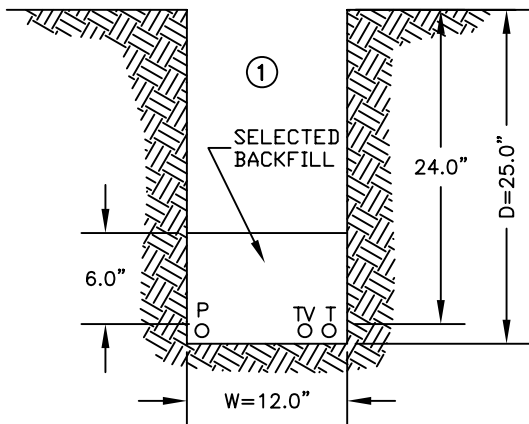

DIRECT BURIED CABLES

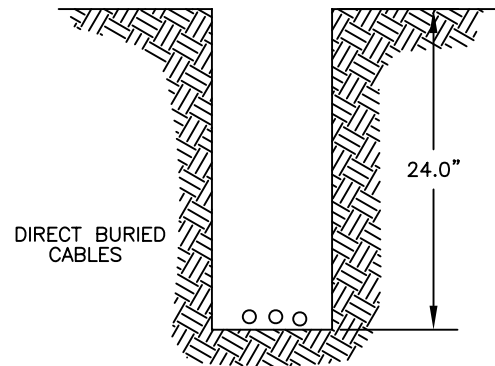

PLOWED INSTALLATION

Date: April 1997

Approved By:

File: E:\eng_std\standard\transpo

No.	Date	Revision	By	Apvd

Joint Utility Trench Sec.
for Secondary/Service Lines

Detail: T-25



City of Port Townsend - Public Works Department

Standard Detail

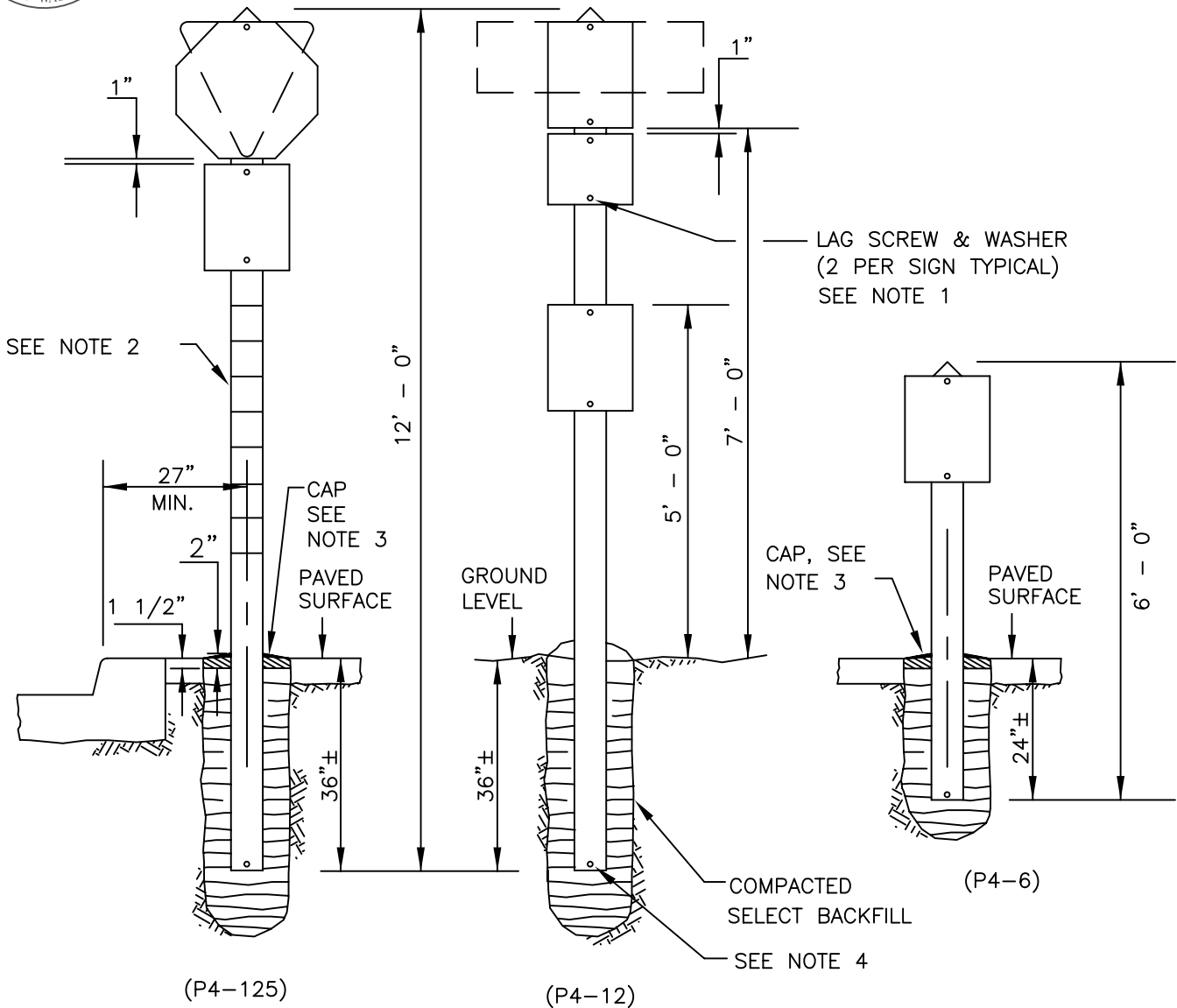

NOTES:

1. 3 1/4 X 5/16" GALVANIZED OR PLATED LOG SCREW & 3/18" I.D. X 1" O.D. NYLON WASHER.
2. CAP SHALL BE THE SAME MATERIAL AS THE SURROUNDING SURFACE.
3. INSTALL 300 GALV. COMMON SPIKE ON THE FACE SIDE OF POST EXCEPT WHEN CONCRETE PAVING EXISTS. SPIKE SHALL BE 8" ABOVE BOTTOM OF POST AND SHALL PROTRUDE 2" FROM POST.

Date: April 1997	No.	Date	Revision	By	Apvd	<h3 style="margin: 0;">Traffic Sign Installation</h3> <p style="font-size: 1.5em; margin: 10px 0 0 0;">Detail: T-26</p>
Approved By:						
File: E:\eng_std\standard\transpo						



City of Port Townsend - Public Works Department

Standard Detail

FOR LOCAL AGENCY USE

TRAFFIC CONTROL PLAN

TRANSPORTATION BUREAU DEPARTMENT OF TRANSPORTATION
STATE OF WASHINGTON



APR 3 1997, 08:23

STANDARD PLAN K-2

Legend
 □ □ □ channelizing devices
 ■ flagger

Typical application of traffic control devices on a two-lane highway where one lane is closed and flagging is provided.

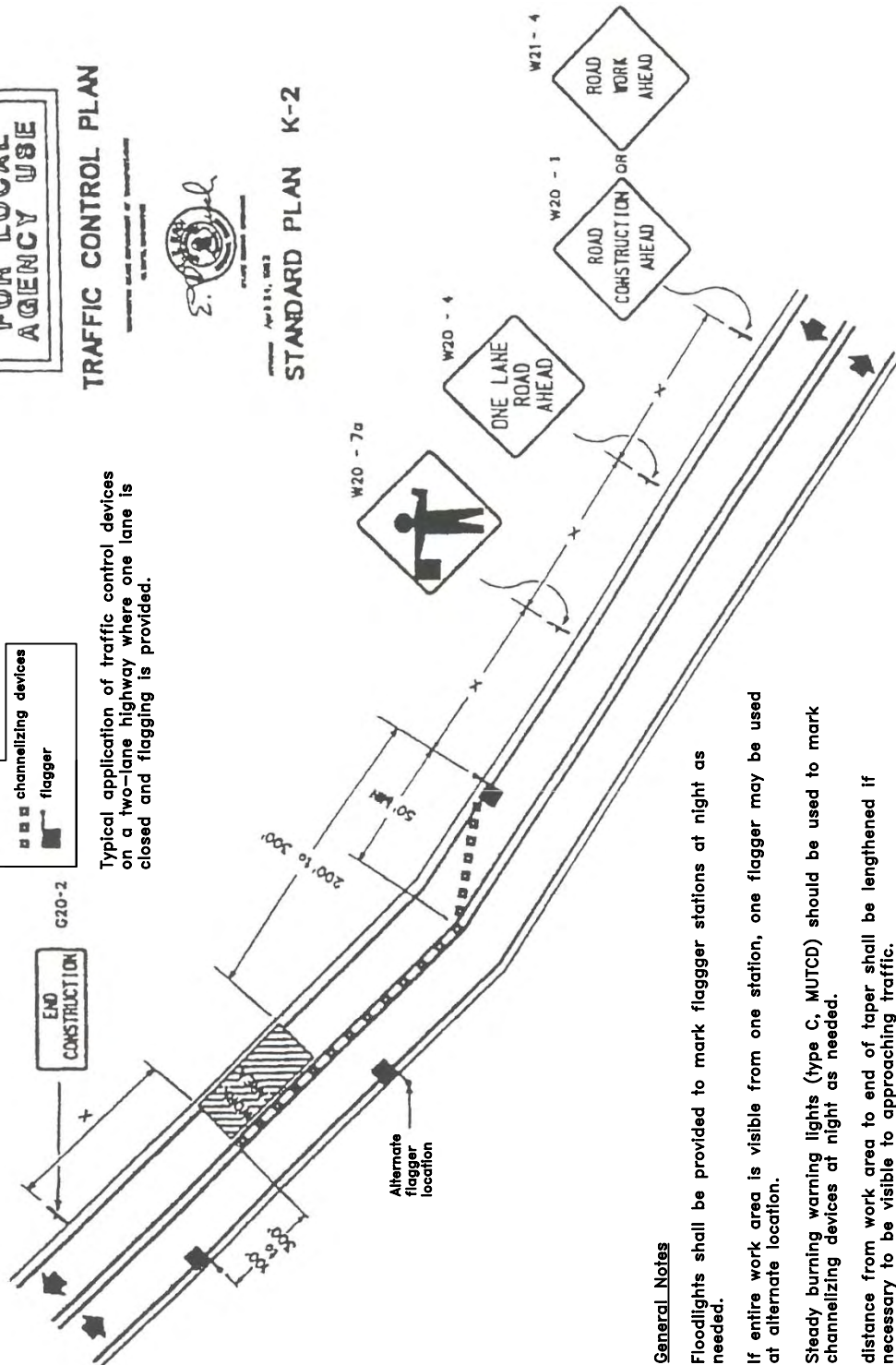

General Notes

- Floodlights shall be provided to mark flagger stations at night as needed.
- If entire work area is visible from one station, one flagger may be used at alternate location.
- Steady burning warning lights (type C, MUTCD) should be used to mark distance from work area to end of taper shall be lengthened if necessary to be visible to approaching traffic.
- Sign sequence is the same for both directions of travel.

Sign Spacing - X (feet)	
Rural Roads	500
Urban Arterials	40/55 mph
Urban Streets Residential and Business Districts	25/35 mph
	250

Date	Revision	By
8-31-90	Revised sign spacing table, flagger dimension, added W21-4, and realigned	ABN
10-18-91	Deleted End Construction signs, added "For Local Agency Use"	ABN
4-24-92	Replaced End Construction sign, added distance from flagger to work area and alternate flagger location, revised notes	ABN

Date: April 1997

Approved By:

File: E:\eng_std\standard\transpo

No.	Date	Revision	By	Apvd

Traffic Control Plan

Detail: T-27

**CHAPTER 6 - APPENDIX B
MAPS**

Map 1	Safe Route to School
Map 2	Functional Classification

City of Port Townsend

Safest Routes to School

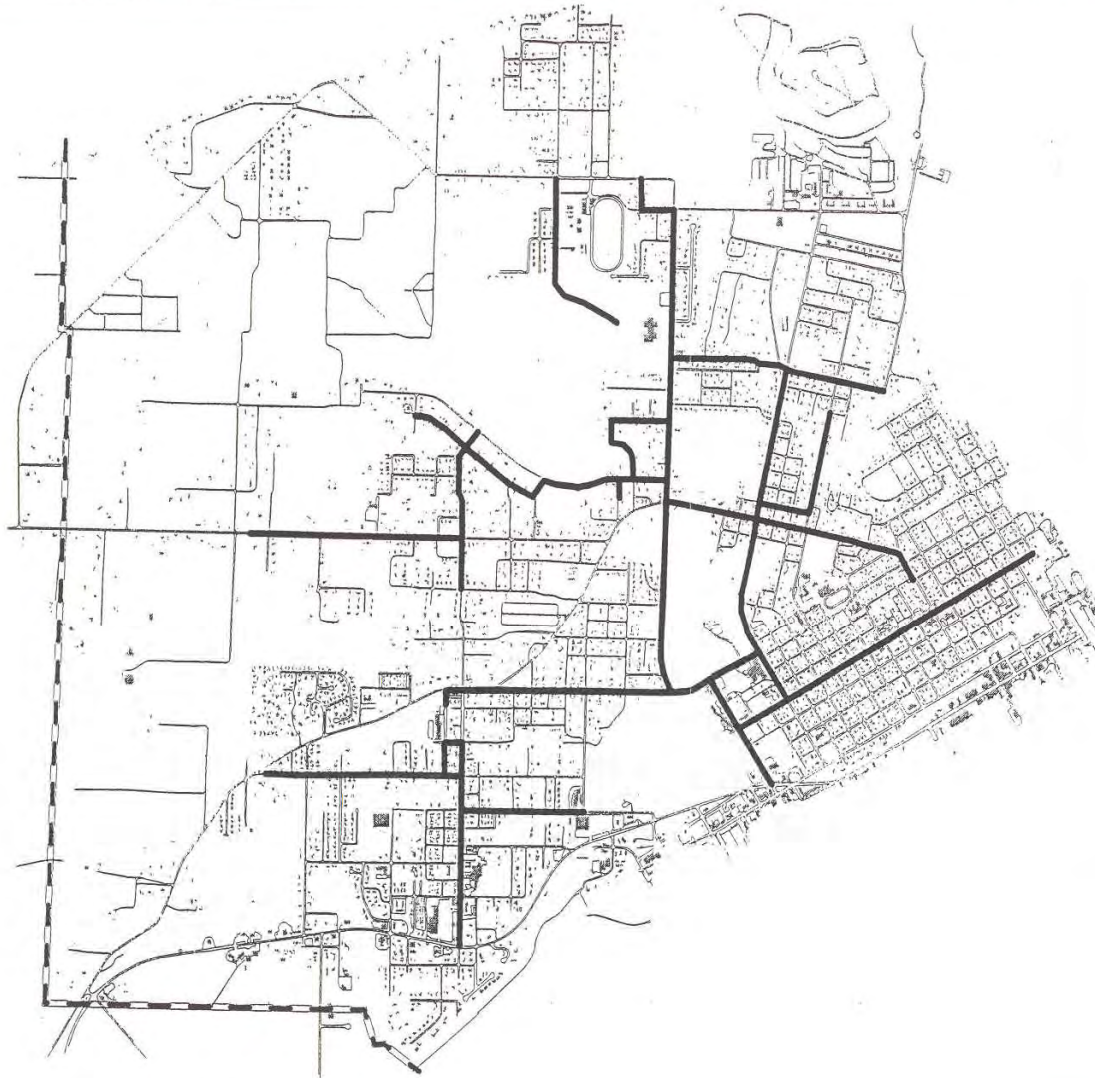

Date Printed: 02/1997

File: P:\activ\street_n\project\school\feroid\project\comp811.apr

Field verification of the accuracy of any information contained in this map is the sole responsibility of the user. Parcel information was obtained from the Jefferson County Assessor's office. Parcel lines are based on available public records and existing map sources, not from field surveys. Parcel lines have been adjusted to better fit planimetric data. This map may contain inaccuracies and should not be relied upon for site-specific analysis, property acquisition, determination of actual rights of way, property dimensions or land area. No representation of warranty regarding the positional accuracy of any map feature is either expressed or implied by publication of this map. By accepting this map, the user releases the City of Port Townsend from any and all direct or indirect liability for actions or decisions made based on information contained in this map.

City of Port Townsend

540 Water Street
Port Townsend, WA, 98368
(360) 385-3000







Safest Routes
to School

1 Inch = 0.5 Miles

City of Port Townsend

Proposed Functional Classification



-  Potential Future Collector or Arterial
-  Principal Arterial
-  Minor Arterial
-  Major Collector
-  Minor Collector
-  Scenic Collector
-  City Limits
Roads

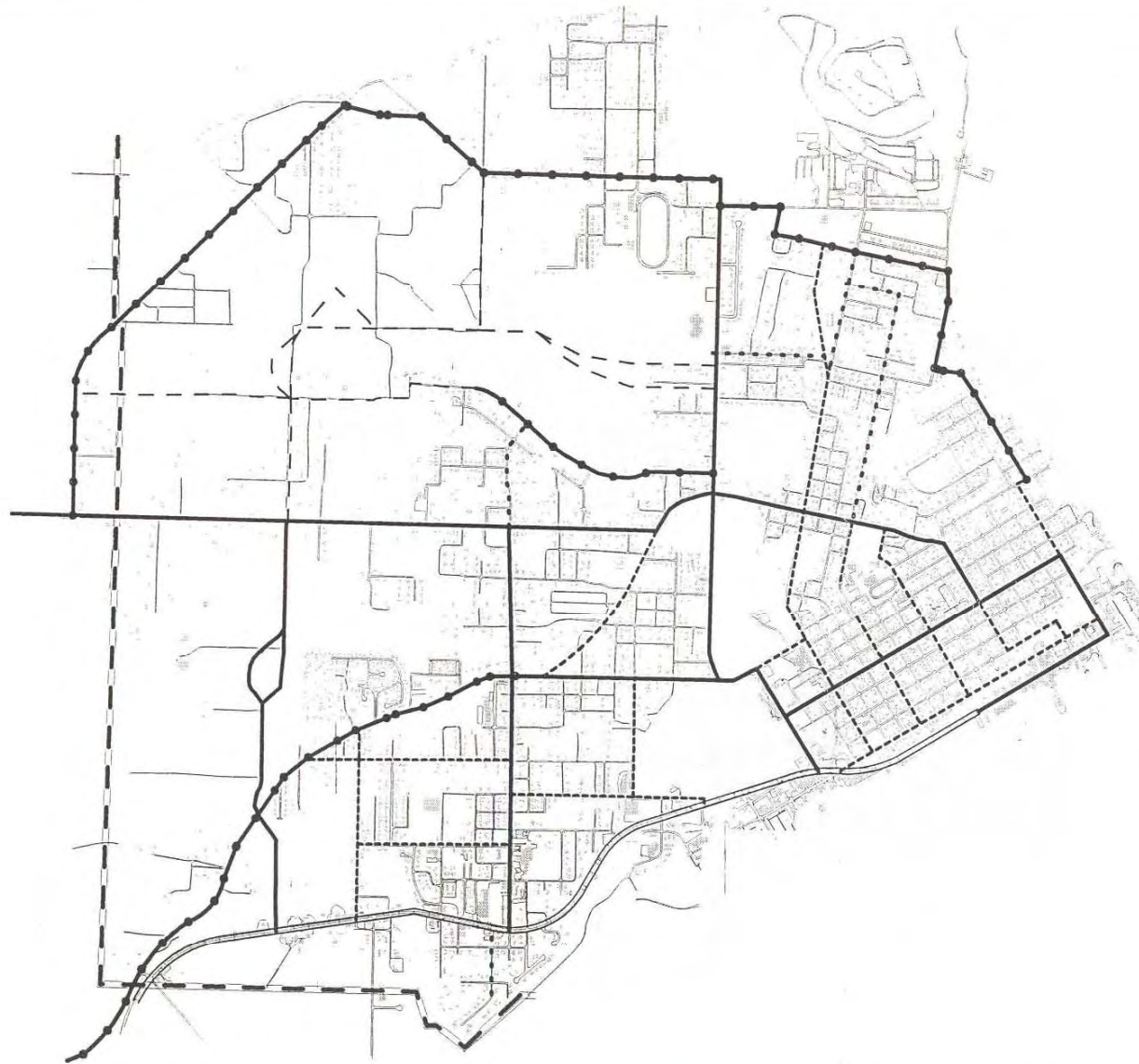

Date Plotted: 3/18/97

File F:\city\street\art_plar\project\cls.apr

Field verification of the accuracy of any information contained in this map is the sole responsibility of the user. Parcel information was obtained from the Jefferson County Assessor's office. Parcel lines are based on available public records and existing map sources, not from field surveys. Parcel lines have been adjusted to better fit planimetric data. This map may contain inaccuracies and should not be relied upon for site-specific analysis, property acquisition, determination of actual rights of way, property dimensions or legal uses. No representation of warranty regarding the positional accuracy of any map feature is either expressed or implied by publication of this map. By accepting this map, the user releases the City of Port Townsend from any and all direct or indirect liability for actions or decisions made based on information contained in this map.

City of Port Townsend

540 Water Street
Port Townsend, WA, 98368
(360) 385-3000

**Proposed Functional
Classification**

1 Inch = 0.5 Miles

**CHAPTER 6 - APPENDIX C
GATEWAY PLAN DRAWINGS**

- Figure 1. Section at the Forest Corridor
- Figure 2. Section at Upper Commercial
- Figure 3. Section at Upper Commercial (Hancock to Grant only)
- Figure 6. Section at S-Curve
- Figure 7. Section at Flats
- Figure 10. Section at Bluff
- Figure 11. Typical Right-of-Way Configuration (three-lane)
- Figure 12. Typical Right-of-Way Configuration (four-lane)

Figure 1:

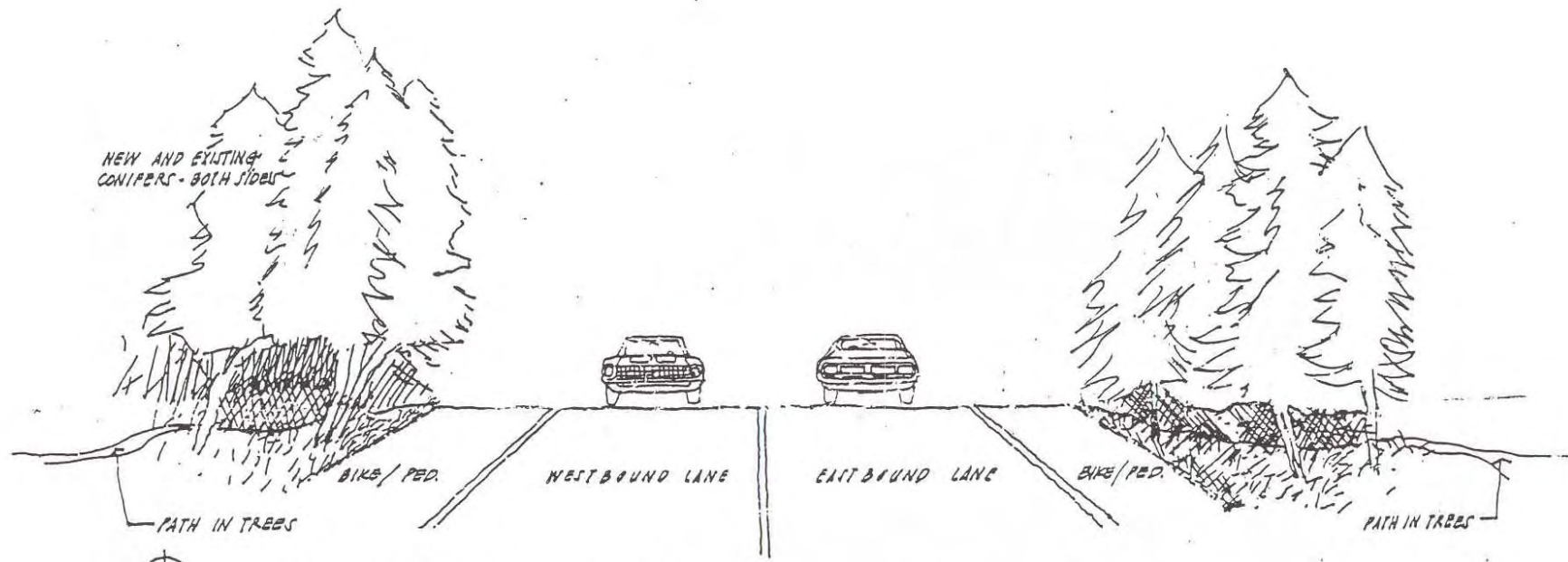

SECTION AT THE FOREST CORRIDOR

Illustrates configuration of existing east and westbound lanes, development of existing shoulders into bike lane, and new pedestrian path through trees. Landscaping includes infill of conifers along both sides.

Figure 2:

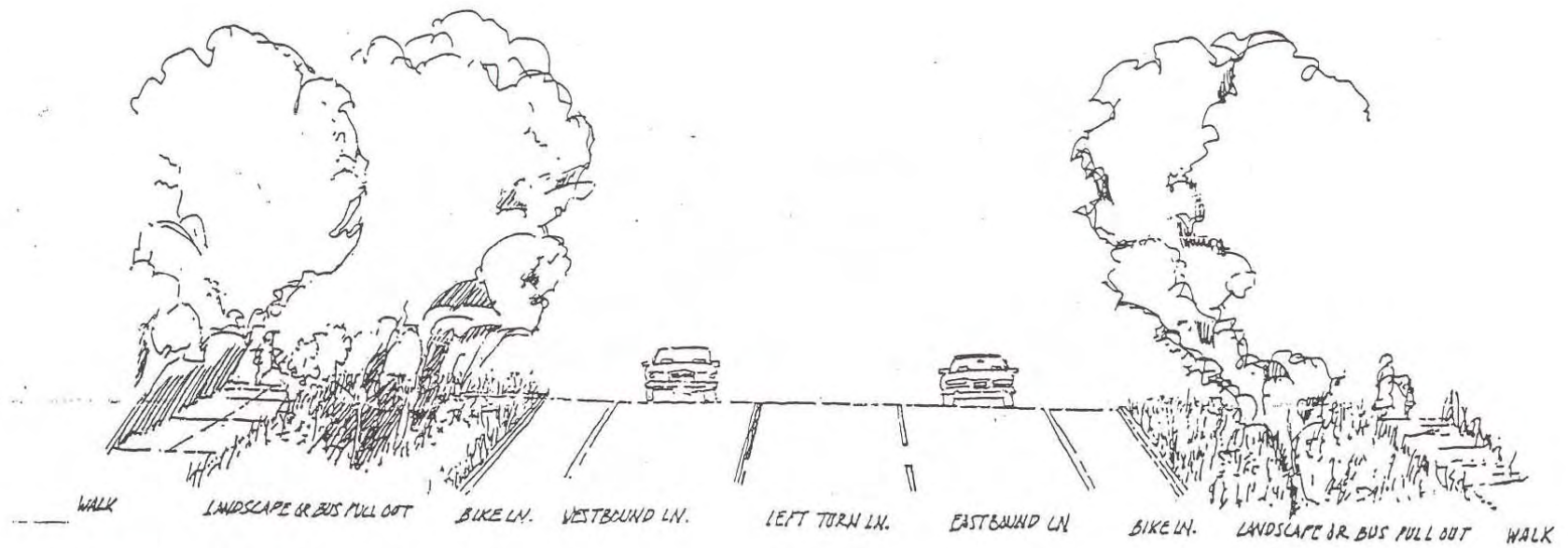

SECTION AT UPPER COMMERCIAL

Illustrates configuration of existing eastbound and westbound lanes, with a new left turn lane. Bicycle lanes and sidewalks are created along both sides of Sims; new trees and shrubs or ground cover are proposed along the sidewalk.

Figure 3:

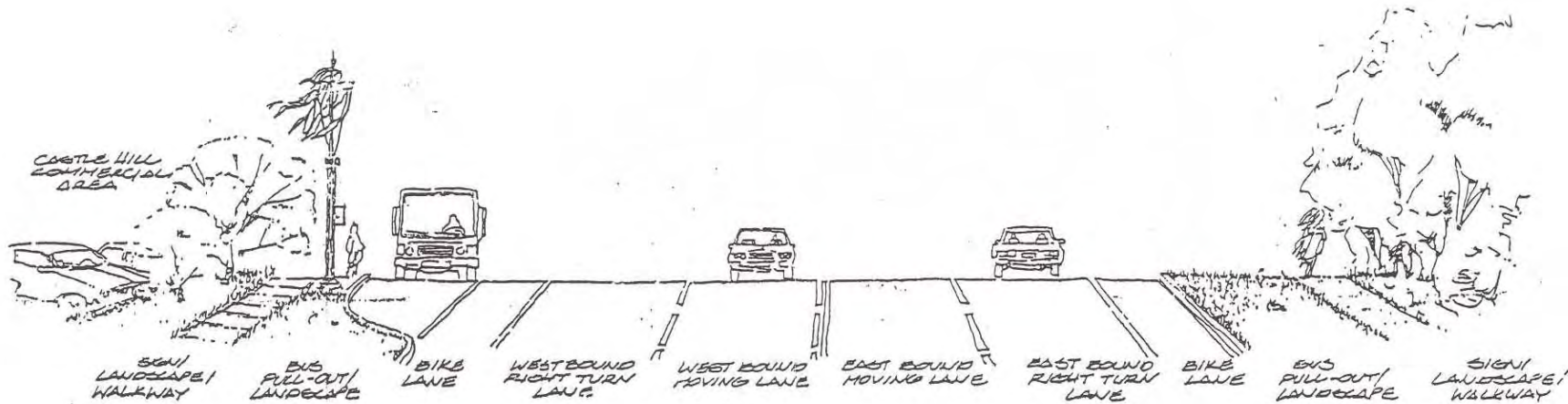

SECTION AT UPPER COMMERCIAL (Hancock to Grant only)

Illustrates configuration of existing eastbound and westbound lanes; along with a new centered left turn lane and a westbound right turn only lane. Bicycle lanes and sidewalks, along with new trees and shrubs, are placed along both sides of Sims.

Figure 6:

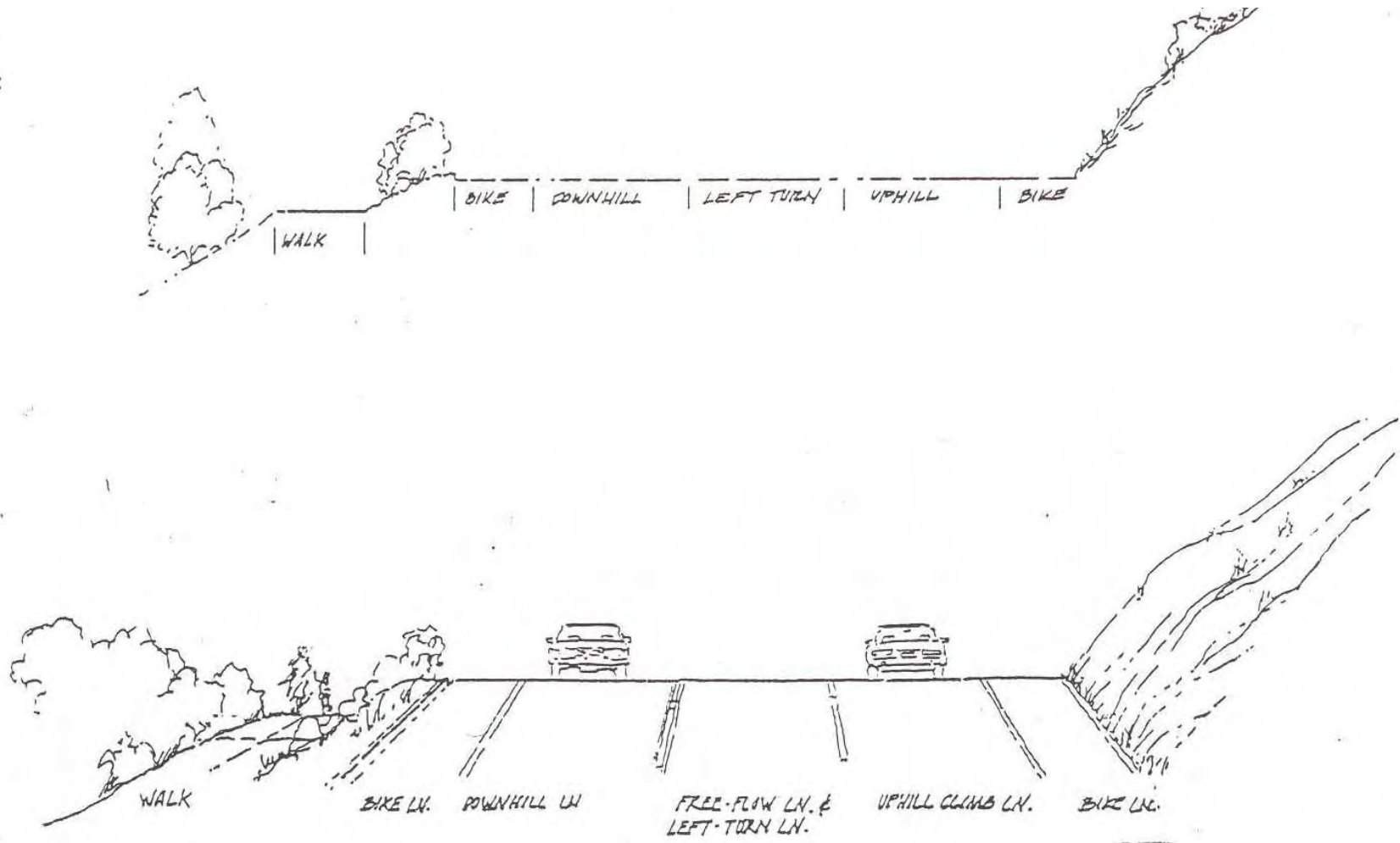

SECTION AT S-CURVE

Illustrates configuration of a new westbound climbing lane and a planter centered between eastbound and westbound lanes. A new shoulder serves as a bike lane and a sidewalk is created along the south. Existing trees may be thinned to improve views.

Figure 7:

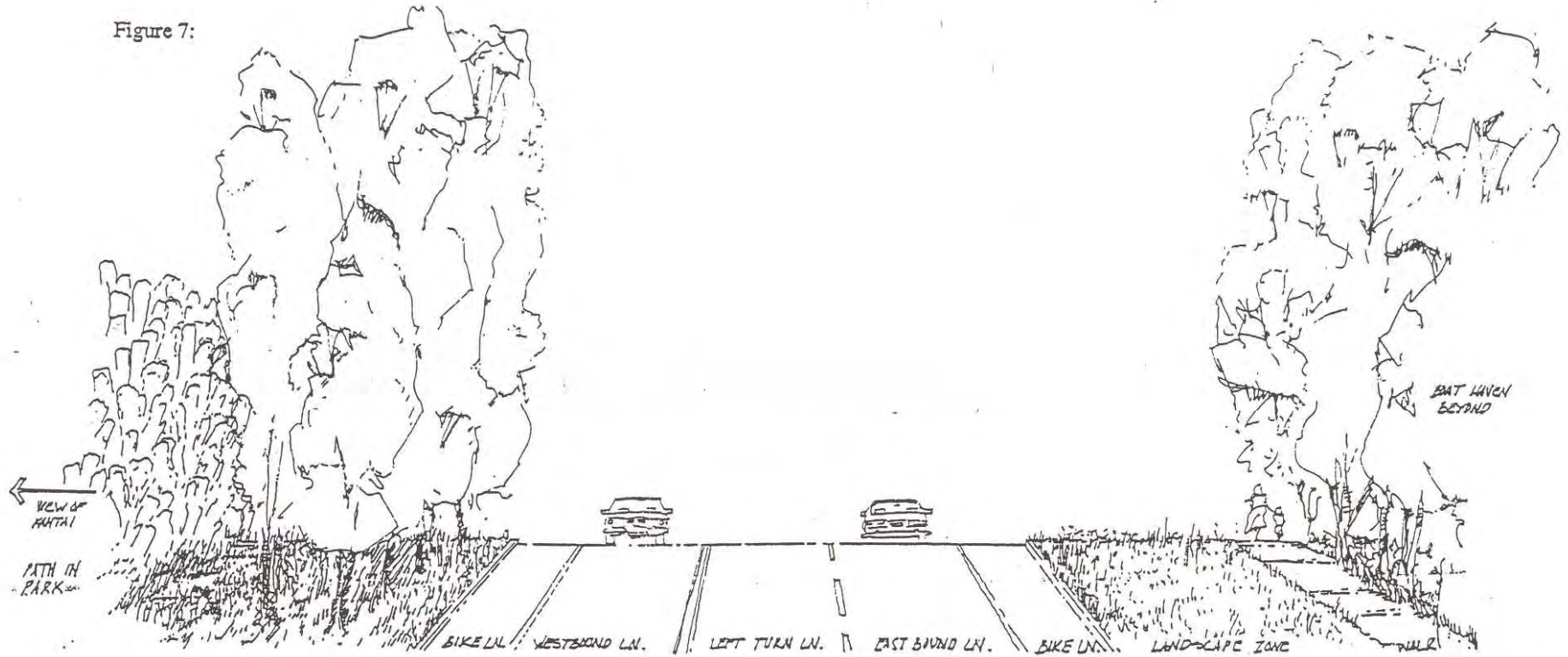

SECTION AT FLATS

Illustrates configuration of new left turn lane between westbound and eastbound lanes. A new shoulder provides bike lane at north, and the existing south shoulder is developed into a bike lane and sidewalk. Existing poplars are thinned as required to improve view to Kah-Tai Park.

Figure 10:

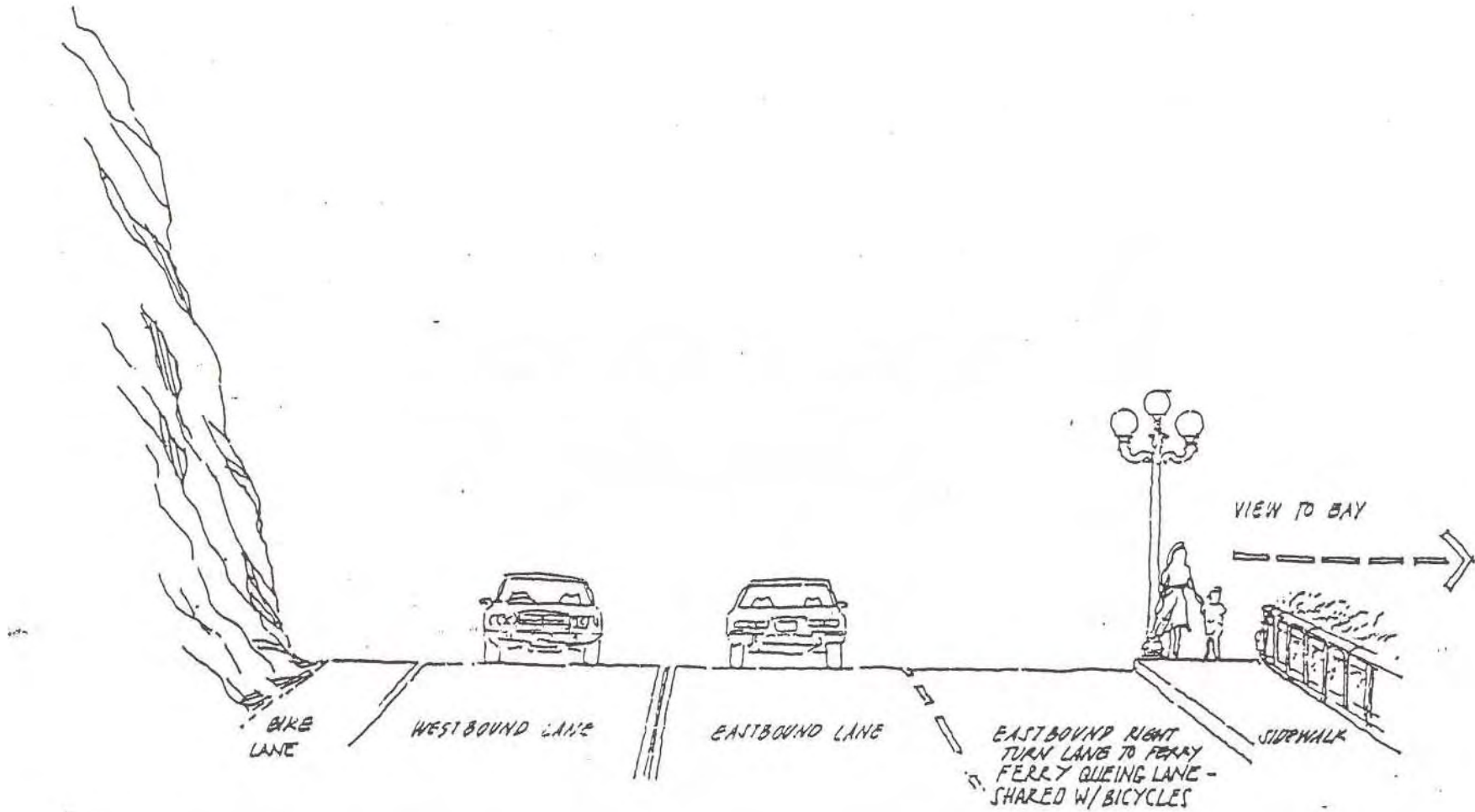

SECTION AT BLUFF

Illustrates configuration of existing east and westbound lanes, with a bike lane along the north shoulder; a new Ferry queuing lane, bike lane, and a sidewalk along south.

Figure 11: Typical Right-of-Way Configuration (three-lane)

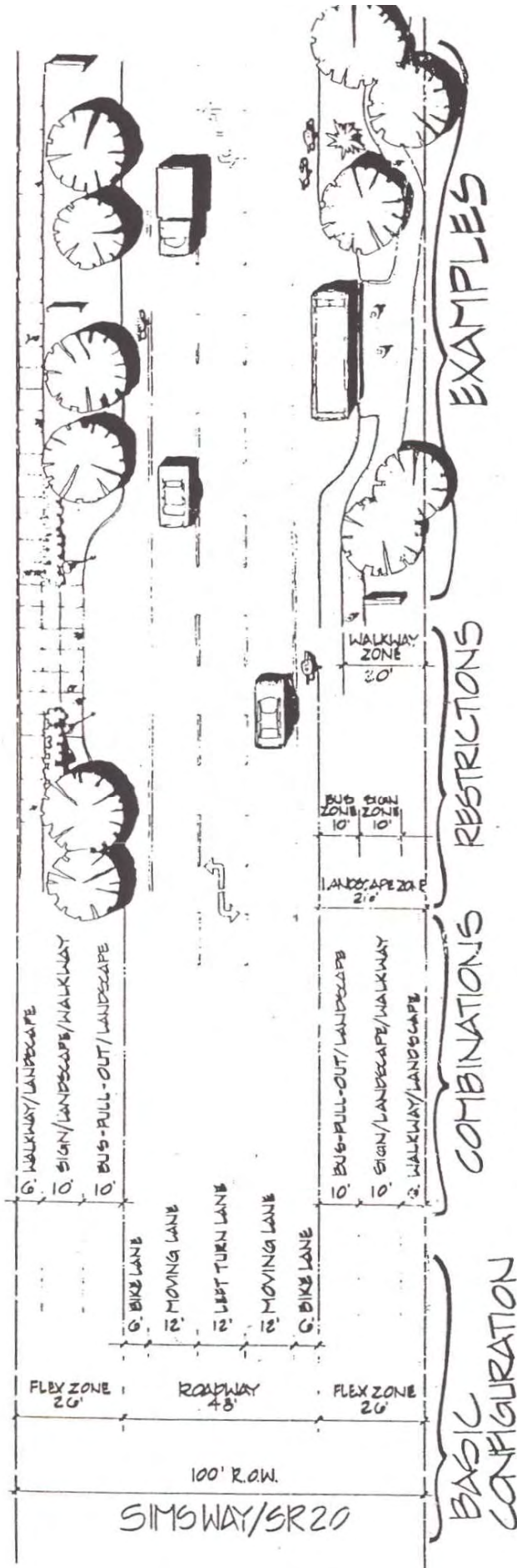
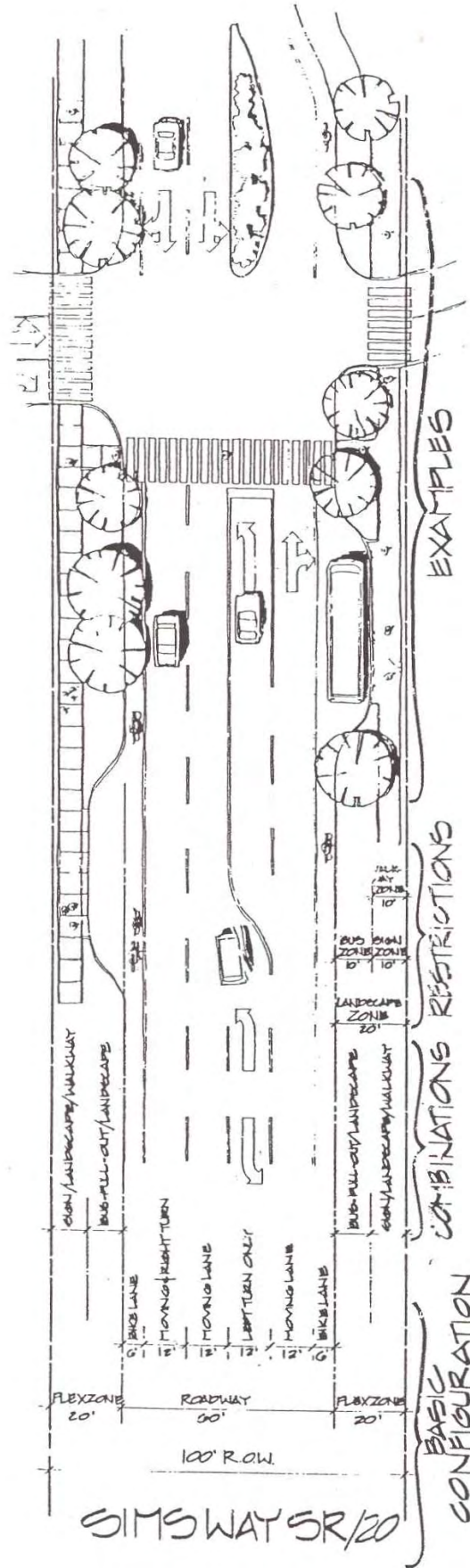

Figure 12: Typical Right-of-Way Configuration (four-lane)



**CHAPTER 6 - APPENDIX D
TREES AND VEGETATION**

Exhibit 1 Unique Trees and Vegetation

Exhibit 2 Street Trees

UNIQUE TREES AND VEGETATION LIST

UNIQUE TREES

Dogwood	<u>Cornus</u>
Madrona	<u>Arbutus menziesii</u>
Quaking aspen	<u>Populus tremuloides</u>
Western Mountain Ash	<u>Fraxinus ornus</u>
Washington Hawthorne	<u>Crataegus phaenophrun</u>

UNIQUE SHRUBS AND OTHER VEGETATION

Nootka Rose	<u>Rosa Nutkana</u>
Ocean Spray	<u>Holodiscus discolor</u>
Prickly Pear Cactus	<u>Oputia fogilis</u>
Red Currant	<u>Ribes sanguineum</u>
Rhododendron	<u>Rhododendron macrophyllum</u>
Shining Oregon Grape	<u>Berberis aquifolium</u>
Swordfern	<u>Polystichum munitum</u>
Snowberry	<u>Symphoricarpus albus</u>

Note: presence of these native varieties indicates a healthy local habitat and all effort should be made to allow these varieties to grow on shoulders and roadside areas to stabilize slopes, prevent invasion of non-native species (such as: thistles and other noxious weeds) and promote wildlife habitat wherever possible on roadside Rights-of-way.

STREET TREE LIST FOR THE CITY OF PORT TOWNSEND

NOTE: The City recommends planting the largest scale tree that is suitable for the designated space.

Small scale trees that may be planted under utility lines

Botanical name, common name, and comments

Acer ginnala (Amur Maple)

Acer platanoides 'Globosum' (Globe Maple)

Acer truncatum (Shantung Maple)

Cercis occidentalis (Western Redbud)

Cornus kousa (Kousa Dogwood)

Crataegus crus-galli 'Inermis' (Thornless Cockspur Hawthorn)

Crataegus x lavalleyi (Lavalley Hawthorn)

Crataegus phaenopyrum (Washington Hawthorn)

Koelreuteria paniculata (Panicled Golden Rain Tree)

Magnolia kobus (Kobus Magnolia)

Malus floribunda (Flowering Crabapple)

Photinia x fraseri (Tree form Photinia)

Prunus cerasifera 'Krauter Vesuvius' (Flowering Plum)

Prunus 'Okame' (Okame Flowering Cherry)

Quercus ilex (Holly Oak)

Styrax japonica (Japanese Snowdrop Tree)

Columnar trees that may be planted under utility lines

Botanical name, common name, and comments

Acer platanoides 'Columnare' (Norway Maple) Columnar form

Acer platanoides 'Compacta' (Norway Maple) compact columnar form

Acer rubrum 'Armstrong', 'Bowhall', 'Scarlet Sentinel', 'Karpic', 'Doric' (Columnar Red Maple)

Malus floribunda 'Tshonoskii' (Japanese Flowering Crabapple)

Pyrus calleryana 'Bradford', 'Capital', 'Chanticleer', 'Redspire' (Flowering pear)

Tilia cordata 'Chancelor' (Littleleaf Linden)

Columnar trees that may not be planted under utility lines

Botanical name, common name, and comments

Acer nigrum 'Greencolumn' (Greencolumn Maple)

Calocedrus decurrens (Incense Cedar)

Carpinus betulus 'Fastigata' (Pyramidal European Hornbeam)

Ginkgo biloba 'Princeton Sentry' (Princeton Sentry Ginko)

Metasequoia glyptostroboides 'Sheridan Spire' (Dawn Redwood)

Quercus robur 'Fastigata' (Upright English Oak)

Medium sized trees that may be planted under utility lines

Botanical name, common name, and comments

Acer campestre (Hedge Maple)

Acer truncatum x A. platanoides 'Warrenred' (Pacific Sunset Maple)

Medium sized trees that may not be planted under utility lines

Botanical name, common name, and comments

Acer platanoides 'Cleveland', 'Deborah', 'Schwedleri', 'Superform' (Norway Maple)

Acer psuedoplatanus (Sycamore Maple)

Aesculus x carnea 'Briotii' (Red Horsechestnut)

Carpinus caroliniana (American Hornbeam)

Ceridiphyllum japonicum (Katsura)

Corylus colurna (Turkish Filbert)

Fraxinus ornus (Flowering Ash)

Gleditsia triacanthos inermis 'Shademaster' (Thornless Honey Locust)

Liquidambar styraciflua (Sweet Gum)

Prunus sargentii (Sargent Cherry)

Pyrus calleryana 'Aristocrat' (Aristocrat Flowering Pear)

Sorbus aria (Whitebeam)

Thuja plicata (Western Red Cedar)

Tilia cordata 'Greenspire' (Littleleaf Linden)

Tilia x euchlora (Crimean Linden)

Zelkova serrata 'Village Green' (Village Green Zelkova)

Large trees not suitable for under utility lines

Botanical name, common name, and comments

Acer platanoides 'Crimson King', 'Emerald Queen' (Norway Maple)

Acer saccharum 'Temple's Upright' (Sugar Maple)

Aesculus hippocastanum 'Baumanii' (Bauman Horsechestnut)

Fagus sylvatica (European Beech)

Fraxinus americana 'Autumn Purple' (American Ash)
Fraxinus excelsior 'Kimberly' (European Ash)
Fraxinus oxycarpa 'Raywood' (Raywood Ash)
Fraxinus pennsylvanica 'Patmore', 'Summit', 'Urbanite' (Green Ash)
Ginkgo biloba (Maidenhair Tree)
Liriodendron tulipifera (Tulip Tree)
Quercus acutissima (Sawtooth Oak)
Quercus coccinea (Scarlet Oak)
Quercus imbricaria (Single Oak)
Quercus phellos (Willow Oak)
Quercus robur (English Oak)
Quercus rubra (Red Oak)
Quercus shumardii (Shumard Oak)
Ulmus 'Pioneer', 'Homestead' (Hybrid Elms)

**CHAPTER 6 - APPENDIX E
STREET GRID, STREETScape, AND PATHWAY EXAMPLES**

Gridiron with pedestrian connectedness and vehicular disconnectedness.

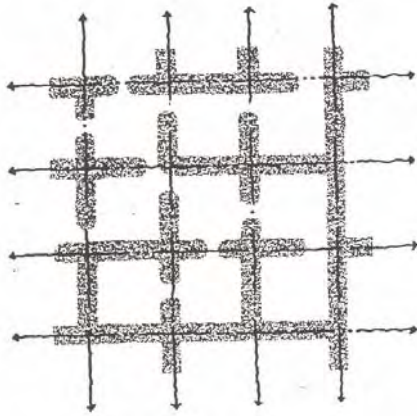

Connected cul-de-sacs and courts with public spaces.

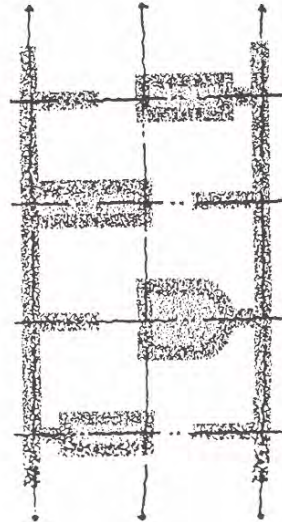

Conventional cul-de-sac pattern.



Pedestrian connected cul-de-sacs.



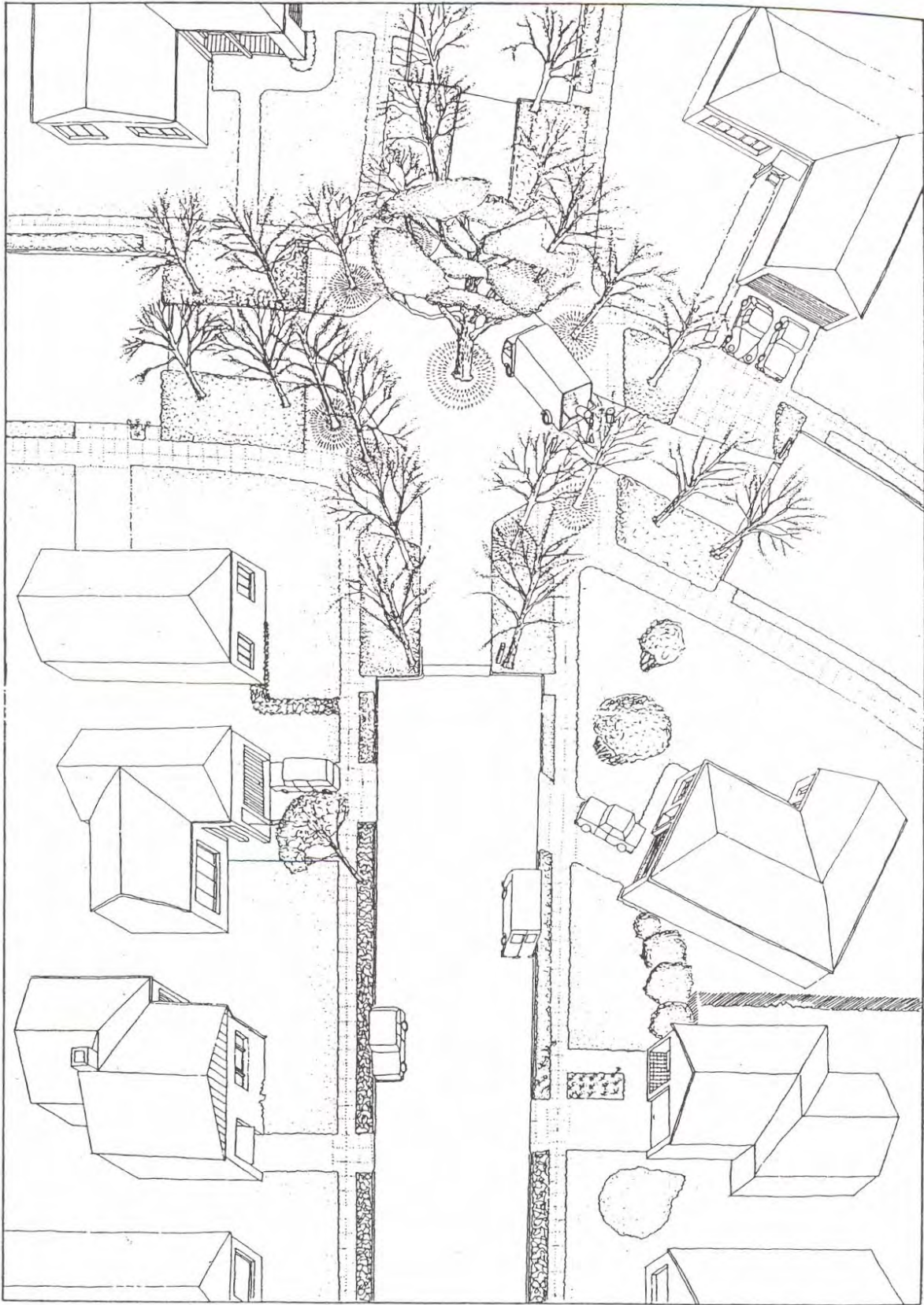

27-3. Streets laid out in the 1950 automobile suburb were designed foremost as speedy and efficient channels for car traffic. The strategic placement of trees on (this page) a street with low traffic volumes, and (b) the same street redesigned for high volumes, can enhance the aesthetic and recreational character of the street, while improving its safety.

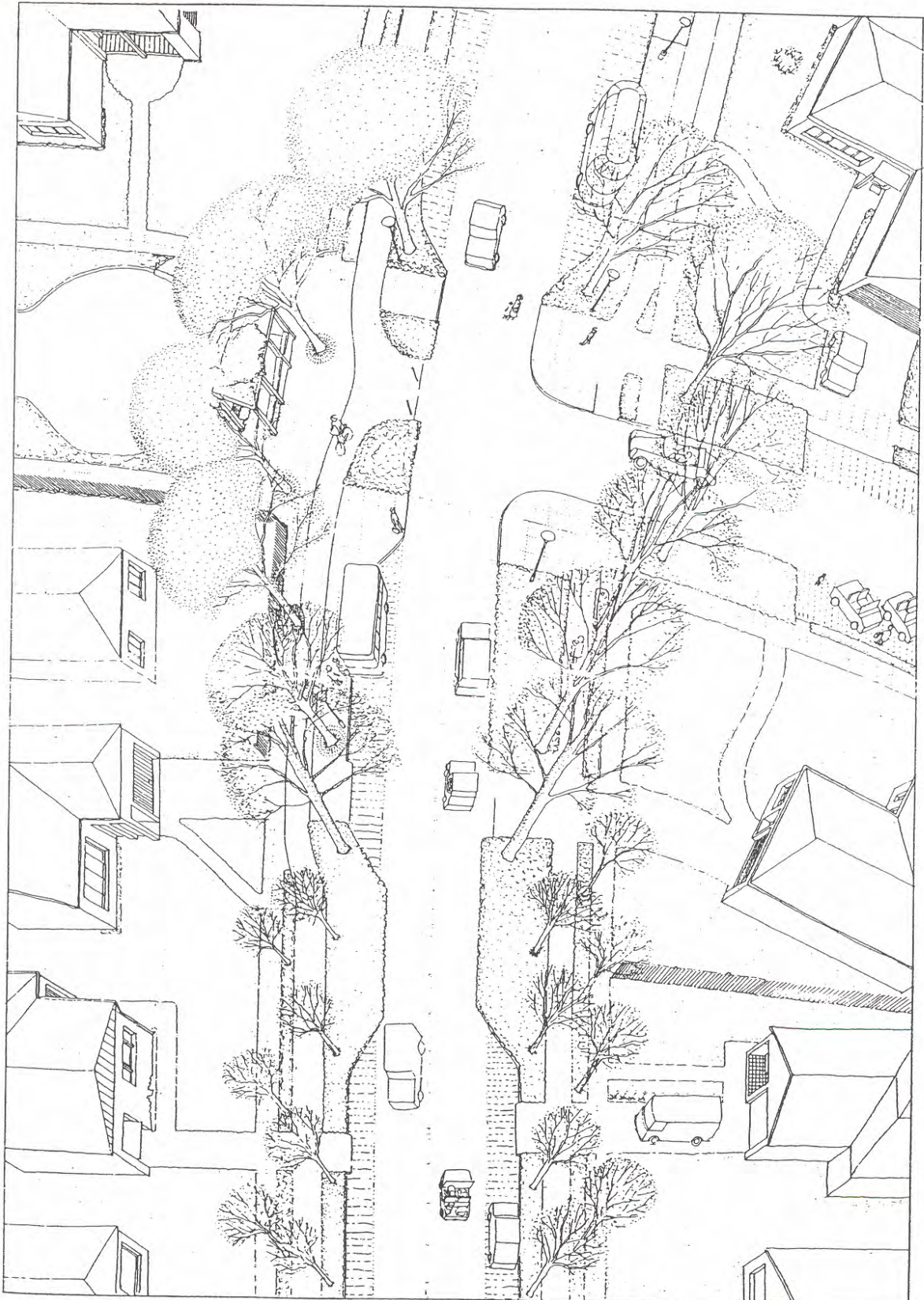

b.

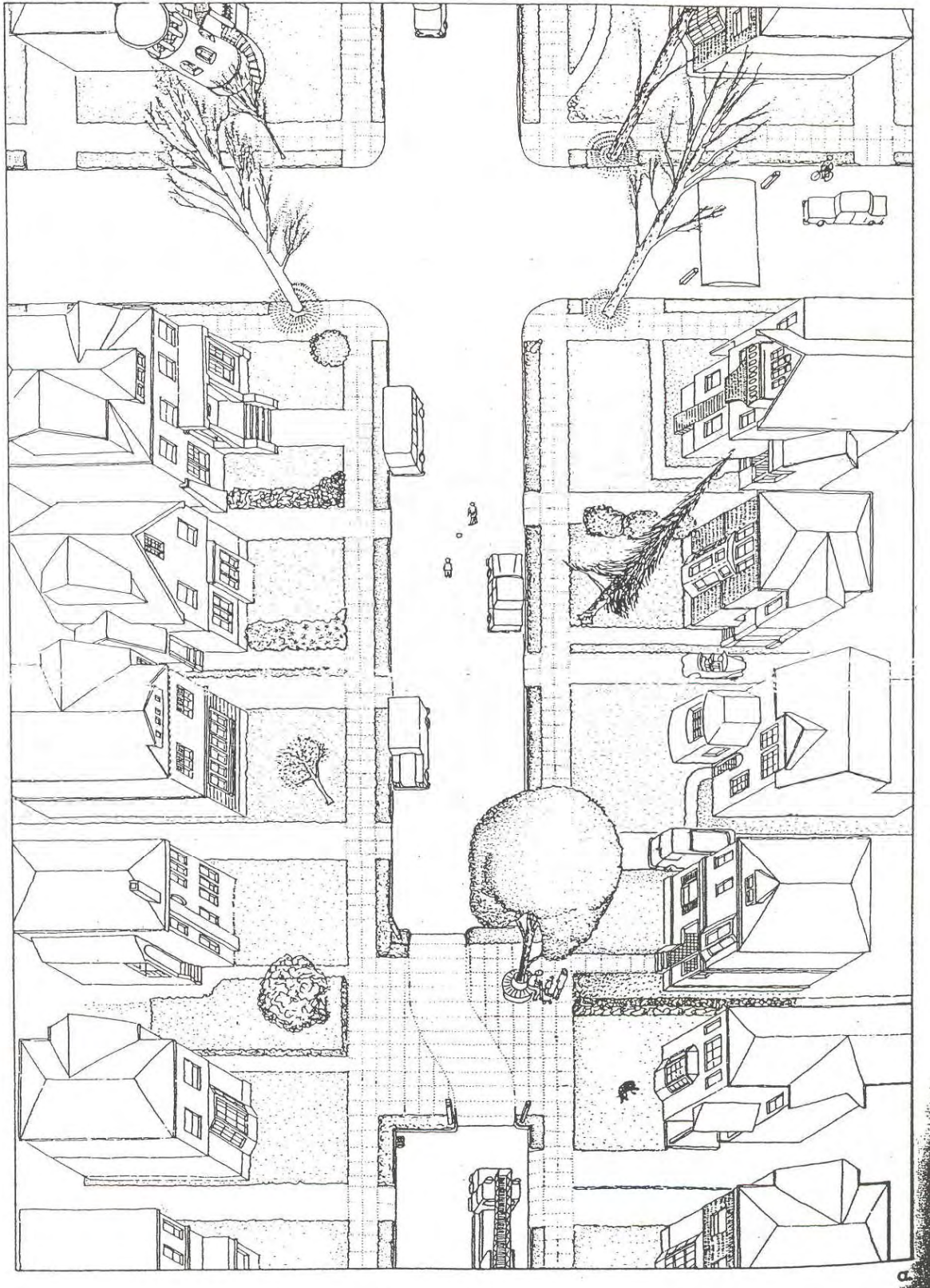

27-2. Streetcar suburbs with (a) lightly trafficked streets would benefit from attractively designed speed bumps that could also serve as pedestrian rest areas, and from amenities, such as bus shelters which would enhance residents' use of public transit.

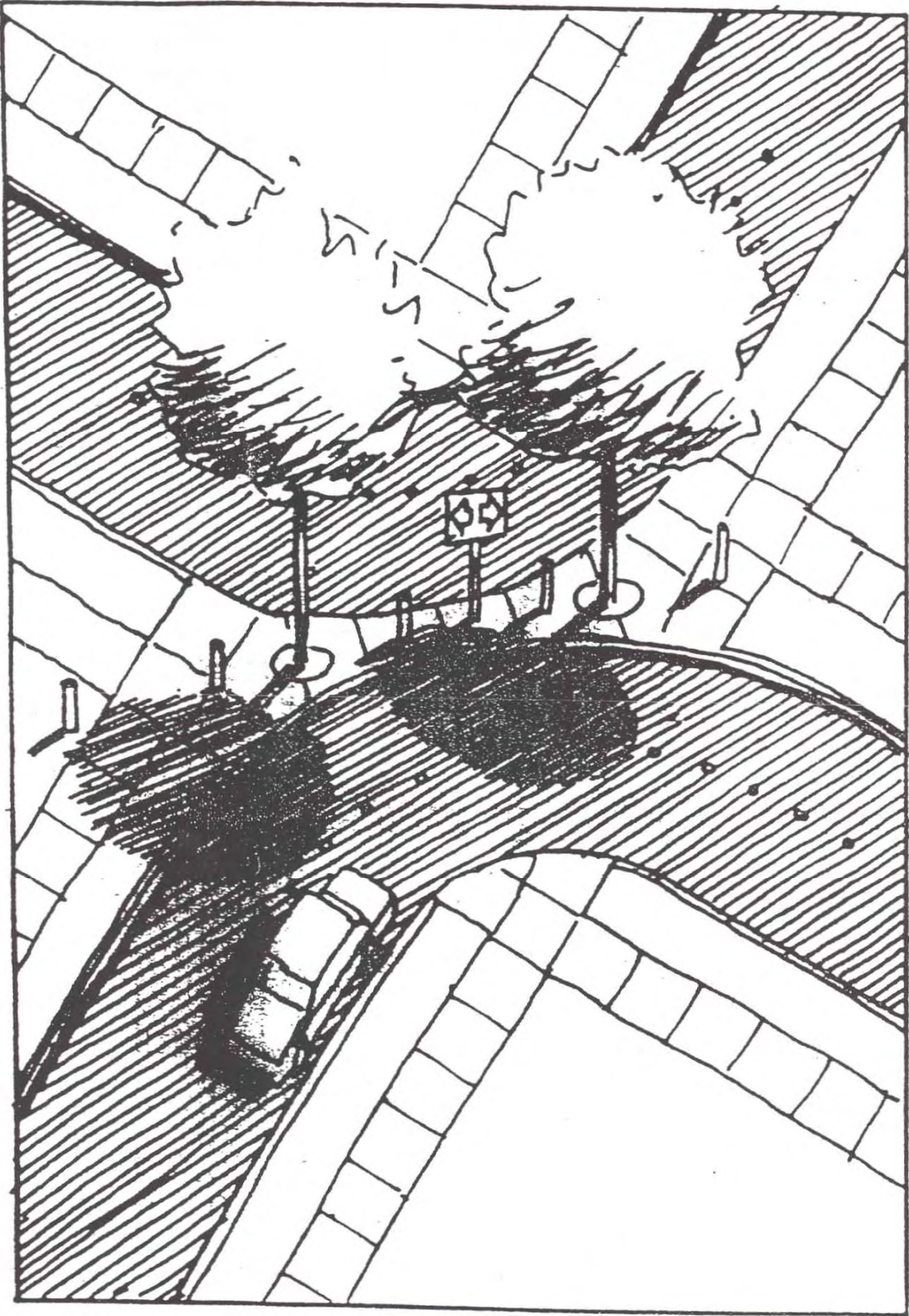

Diagonal Diverters

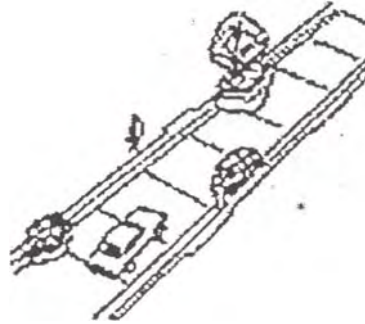

Figure 31. Pinch Points in Pavement

Typical Application

Effective in limiting the ability of cars to pass one another through narrow pavement, and thus reduce speeds.

Description

Constrictions are built in a form of extended planters or sidewalks at intervals along one side or both sides of the street. Width is influenced by various factors such as traffic, volume, provision for large vehicles and one or two-way traffic. Pinch points are usually most effective when combined with other controlling measures such as speed bumps. Provisions for cyclists and drainage may be necessary in some cases.

This European technique for controlling traffic is not widely used in the United States. Seven of the surveyed cities indicate actual use of the technique, and ten others show an interest and possible application in future development. The majority of cities (52) have not used the technique.

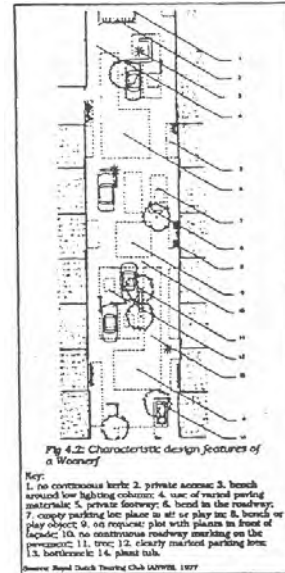

Figure 41. Shared Streets

Description

The shared street concept (Woonerf) is the prevalent technique for residential neighborhood traffic control in Europe. Its fundamental concept is an antithesis to the notion of segregating pedestrians and vehicles. It is defined by the elimination of the traditional division between roadway and sidewalks. One road surface is created and the maximum vehicle speed is restricted to a walking pace. Thus pedestrians, children at play, bicyclists, parked cars, and moving cars all share the same surface. Though it seems these uses conflict with each other, the physical design is such that the pedestrian has primary rights, while the driver is the intruder. Various studies and surveys conducted in the last twenty years indicate a considerable reduction in traffic speed and accidents. They also show an increase of street's social interaction, play, and a high degree of satisfaction by the residents.

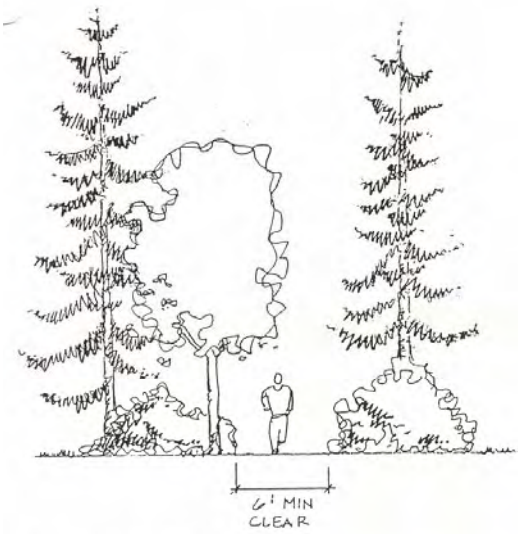

Figure IV - 9. Use Trail

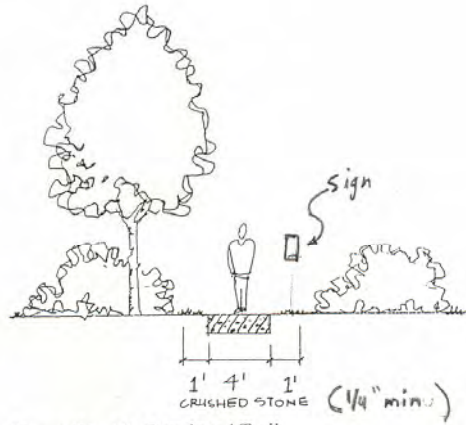
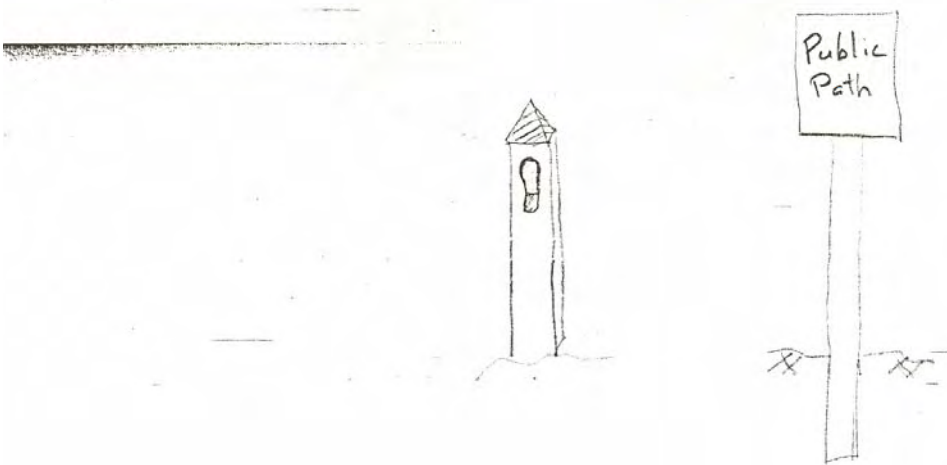
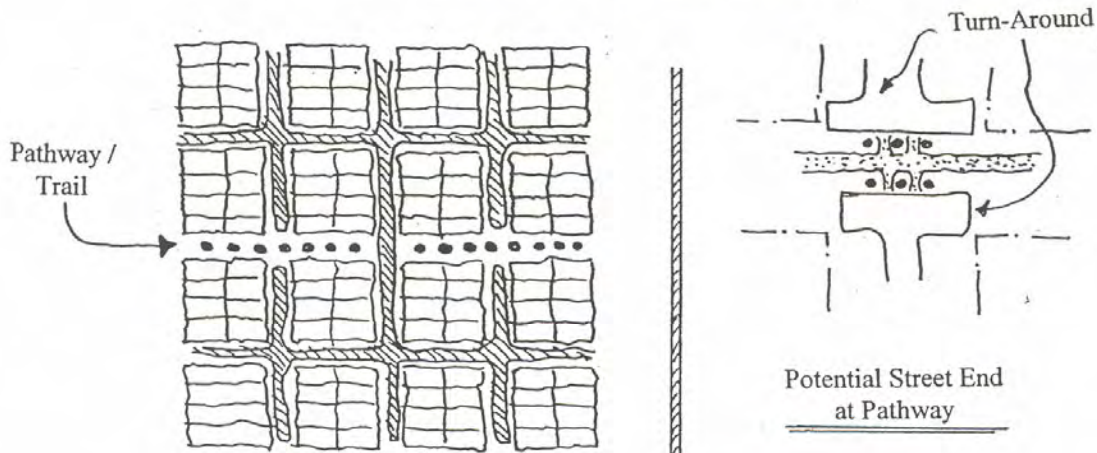

Figure IV - 10. Developed Trail

Secondary Neighborhood Connector



NEIGHBORHOOD STREETS
ALTERNATIVE USE OF RIGHTS-OF-WAY



Minimize Trail Crossings

Traffic Calming, Diversion

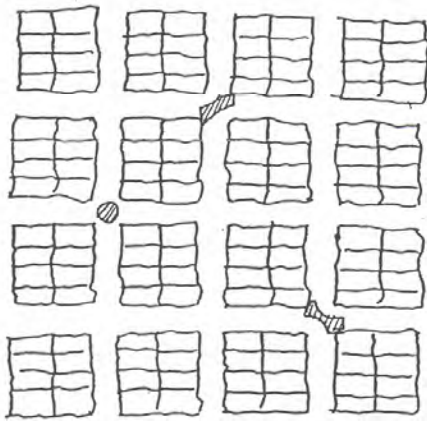

Stormwater Detention

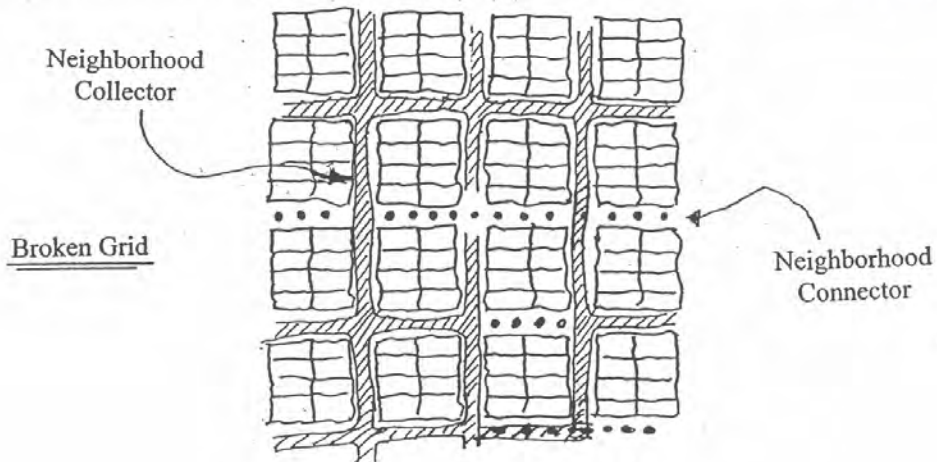
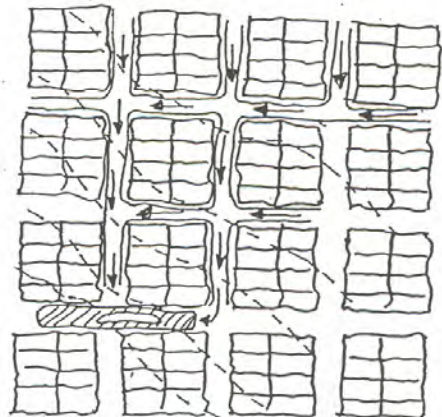

**CHAPTER 6 - APPENDIX F
TRAFFIC IMPACT ANALYSIS**

TRAFFIC IMPACT ANALYSIS

Introduction

1. A traffic impact analysis is a specialized study of the impacts a certain type and size of development will have on the surrounding transportation system. The traffic impact analysis is an integral part of the development impact review process. It is especially concerned with the generation, distribution, and assignment of traffic to and from the “new development.” The purpose of the analysis is to determine what impact the development traffic will have on the existing and proposed street network and what impact the existing and projected traffic on the street system will have on the “new development.” A “new development” is a site action that triggers SEPA requirements which can include cumulative impacts.
2. The BCD Department in consultation with the Public Works Department will determine if there is a need for a traffic impact analysis. In general the need for this analysis will be based upon the size of the development proposed, existing street and intersection conditions, traffic volumes, accident history, community concerns, and other pertinent factors relating to traffic impacts attributable to “new developments.”
3. When Required. If a site action requires an Environmental Checklist to be prepared, a Traffic Impact Analysis may be required if any of the following conditions are met. This does not preclude the SEPA Responsible Official’s authority to require additional analysis if in his judgment such analysis is necessary or to waive this analysis.
 - a. The “new development” generates more than 20 vehicles in the peak direction of the peak hour on the adjacent streets and intersections. This would include the summation of all turning movements that affect the peak direction of traffic.
 - b. The “new development” generates more than 25% of site-generated peak hour traffic through a signalized intersection or the “critical” movement at an unsignalized intersection.
 - c. The “new development” is within an existing or proposed transportation benefit area. This may include Latecomer Agreements, Transportation Benefit Districts (TBD), Local Improvement Districts (LID), or local/state transportation improvement areas programmed for development reimbursements.
 - d. The “new development” may potentially affect the implementation of the street system outlined in the Transportation Element of the Comprehensive Plan, the Transportation Improvement Program, or any other documented transportation project.
 - e. The “new development” proposes a rezone of the subject property that could significantly change transportation patterns.
 - f. The original analysis of the site is over two years old.
4. Qualifications for Preparation of Documents. Traffic Impact Analysis shall be conducted under the direction of a responsible individual or firm acceptable to the BCD Director and

Public Works Director. The analysis shall be prepared by an engineer licensed to practice in the State of Washington with special training and experience in traffic engineering.

5. Scope of Work. The level of detail and the scope of work of a Traffic Impact Analysis may vary with the size, complexity, and location of the “new development.” The analysis shall be a thorough review of the immediate and long-range effects of the “new development” on the transportation system.
 - a. A New Development Description
 - i. Provide a reduced copy of the site plan showing the type of development, street system, right-of-way limits, access points, and other features of significance in the “new development.” Also include pertinent off-site information such as intersections, driveways, land-use descriptions and other significant features with respect to the development.
 - ii. Provide a “vicinity map” of the project area showing the transportation system to be impacted by the development.
 - iii. Discuss specific development characteristics such as type of development proposed (single-family, multi-family, retail, industrial), internal street network, proposed access locations, parking requirements, zoning, and other pertinent factors.
 - iv. Discuss project completion and occupancy schedule.
 - b. Existing Conditions
 - i. Discuss street characteristics including functional class, number of traveled lanes, lane width, shoulder treatment, bicycle paths, and intersection traffic control.
 - ii. Identify safety and access problems including discussions on accident history, sight distance restrictions, traffic control, and pedestrian conflicts.
 - iii. Obtain all available traffic data from the city and other jurisdictions as applicable. If data is not available, then data shall be collected by the firm to supplement the discussions and analysis.
 - iv. Conduct manual peak hour turning movement counts at study intersection, if traffic volume data is more than three (3) years old, unless otherwise directed by the city.
 - v. A figure shall be prepared showing existing average daily traffic and peak hour traffic volumes on the adjacent streets and intersections in the study area. Complete turning movement volumes shall be illustrated.
 - c. Development Traffic
 - i. Elements of the analysis shall be conducted initially to identify the limits of the study area. The study area shall include all pertinent intersections and streets impacted by the development traffic.
 - ii. Individual or firm preparing the analysis shall submit a figure illustrating the proposed “trip distribution” for the new development to the City Engineer. Once the figure is approved, a formal “scoping” of the study area and the study contents can be conducted to clearly identify the elements of the study.
 - iii. Methodology and procedures used in preparing the trip generation and trip distribution elements of the analysis are as follows:

- (1) Trip Generation - Site-generated traffic of the “new developments” shall be estimated using the latest edition of the ITE TRIP GENERATION MANUAL. Variations of trip rates will require the approval of the City Engineer. Average trip rates shall be used for all land-use categories where applicable. Trip rate equations will be allowed for those land uses without average rates.
 - (2) Site traffic shall be generated for daily and A.M. and P.M. peak hour periods. Adjustments made for “passer-by” and “mixed-use” traffic volumes shall follow the methodology outlined in the latest edition of the ITE TRIP GENERATION MANUAL. A “passer-by” traffic volume discount for commercial centers shall not exceed 25% unless approved otherwise by the City Engineer. For multi-use and/or “phased” projects, trip generation tables shall be prepared showing proposed land-use, trip rates, and vehicle trips for daily and peak hour periods and appropriate traffic volume discounts, if applicable.
 - (3) Trip Distribution - The trip distribution for a “new development” shall be approved by the City Engineer and prior to the formal scoping of the analysis. The methodology shall be clearly defined and discussed in detail in the analysis. The analysis shall identify other transportation modes that may be applicable, such as transit, bicycle, and pedestrian use. New developments are encouraged to implement Transportation Demand Management practices such as “Flex Time” for employees and ride sharing programs including car pools, van pools, shuttle buses etc.
- iv. Future Traffic
- (1) Future Traffic Conditions not including Site Traffic. Future traffic volumes shall be estimated using information from transportation models or applying an annual growth rate to the base-line traffic volumes. The future traffic volumes shall be representative of the time of full build out based upon current zoning. The City Engineer will determine an appropriate growth rate, if that option is utilized. In addition, proposed “on-line” projects shall be compared to the increase in traffic by applying an annual growth rate. If modeling information is not available, the greatest traffic increase from either the “on-line” developments or the application of an annual growth rate shall be used to forecast the future traffic volumes.
 - (2) Future Traffic Conditions including Site Traffic. The site-generated traffic shall be assigned to the street network in the study area based on the approved trip distribution model. The site traffic shall be combined with the forecasted traffic volumes to show the total traffic conditions estimated at development completion. A future will be required showing daily and peak period turning movement volumes for each traffic study intersection.
- v. Traffic Operations
- (1) The level of service (LOS) and capacity analysis shall be conducted for

each pertinent intersection in the study area as determined by the BCD and Public Works Directors. The methodology and procedures for conducting the capacity analysis shall follow the guidelines specified in the Highway Capacity Manual-Special Report 209, 1985 Edition. The individual or firm preparing the analysis shall calculate the intersection LOD for each of the following conditions:

- (a) Existing peak hour traffic volumes
 - (b) Existing peak hour traffic volumes including site-generated traffic
6. Future traffic volumes not including site traffic
 7. Future traffic volumes including site traffic
 8. Level of Service results for each traffic volume scenario.
 - a. The Level of Service Table shall include the LOS results for A.M. and P.M. peak periods, if applicable. The table shall show LOS conditions with corresponding vehicle delays for signalized intersections and LOS conditions for the critical movements at unsignalized intersections. For signalized intersections, the LOS conditions and average vehicle delay shall be provided for each approach and the intersection as a whole.
 - b. The capacity analysis for existing signalized intersections shall include existing phasing, timing, splits and cycle lengths in the analysis as observed and measured during the peak hour traffic periods. All traffic signal system operational data may be obtained from the Public Works Department.
 - c. If the “new development” is scheduled to be completed in phases, the analysis shall conduct a LOS analysis for each separate phase of the development. The incremental increases in site traffic from each phase shall be included in the LOS analysis for each proceeding year of development completion.
 - d. The Public Works Department may require that the analysis be conducted on computer software compatible with City software.
 9. Mitigation
 - a. The analysis shall include a proposed mitigation plan. The mitigation may be either the construction of necessary transportation improvements or contributions to any established transportation impact fund.

ITE TRIP GENERATION RATES BY MAJOR LAND USE CATEGORIES

Land Use Type*	Average Weekday Trip Generation Rates
<hr/>	
Residential	Trips per Indicated Measure: Dwelling Unit
Single-family detached	10.06
Condominium/townhouse**	5.86
Multi-Family apartment	6.60
Mobile home park	4.81
Retirement community	3.30
Recreational home (owner)	3.16
<hr/>	
Office Building	Trips per Indicated Measure: 1,000 gross sq.ft. of building area
General office, 10,000 gross sq.ft.	24.39
General office, 50,000 gross sq.ft.	16.31
Medical office building	34.17
Office park	11.40
Research center	6.09
<hr/>	
Retail	Trips per Indicated Measure: 1,000 gross sq.ft. of leasable area
Specialty retail	40.67
Discount store	71.16
Shopping center	
10,000 sq.ft. gross leasable area	166.35
50,000 sq.ft. gross leasable area	94.71

Land Use Type*

Average Weekday Trip Generation Rates

Industrial	Trips per Indicated Measure:	
	Employee	1,000 gross sq.ft. of building area
Light industrial	3.02	6.97
Industrial park	3.41	6.97
Manufacturing	2.09	3.85
Warehousing	3.89	4.88
Mini-Warehouse	56.28	2.61

Lodging	Trips per Indicated Measure:	
	Employee	Room
Hotel	14.34	8.70
Motel	12.81	10.19

Institutional	Trips per Indicated Measure:	
	Employee	Student
Elementary school	13.10	1.03
High school	16.79	1.39
Junior/community college	10.06	1.55
Library	49.50	45.50

(per 1,000 gross sq.ft.)

Notes:

*For definitions, see below.

**High-rise condominium (>2 stories) = 4.18

RESIDENTIAL STREET HIERARCHY: DEFINITION

<i>Residential Street Type</i>	<i>Function</i>	<i>Guideline Maximum ADT</i>
1) Local Access Street	<p>Lowest order of residential streets. Provides frontage for access to lots, and carries traffic having destination or origin on the street itself. Designed to carry the least amount of traffic at the lowest speed. All, or the maximum number of housing units, shall front on this class of street.</p> <p>Residential access streets should be designed so that no section conveys an ADT greater than 250. Each half of a loop street may be classified as a single residential access street, but the total traffic volume generated on the loop street should not exceed 500 ADT, nor should it exceed 250 ADT at any point of traffic concentration.</p>	<p>250 (each loop) 500 (total)</p>
2) Minor (neighborhood) Collector	<p>Middle order of residential street. Provides frontage for access to lots and carries traffic of adjoining residential access streets. Designed to carry somewhat higher traffic volumes with traffic limited to motorists having origin or destination within the immediate neighborhood. Is not intended to interconnect adjoining neighborhoods or subdivisions and should not carry regional through traffic.</p> <p>Subcollectors shall be designed so that no section conveys an ADT greater than 500. Each half of a loop subcollector may be classified as a single subcollector street, but the total traffic volume conveyed on the loop street should not exceed 1,000 ADT, nor should exceed 500 ADT at any point of traffic concentration.</p>	<p>500 (each loop) 1,000 (total)</p>
3) Major Collector	<p>Highest order of residential streets. Conducts and distributes traffic between lower-order residential streets and higher-order streets. Function is to promote safe, free traffic flow; therefore, parking and direct access to homes from this level of street should be discouraged.</p>	<p>3,000 (total)</p>
4) Minor Arterial	<p>A higher order, interregional road in the street hierarchy. Conveys traffic between centers.</p>	<p>3,000 +</p>

CHAPTER 7 – APPENDIX

Tree List for the City of Port Townsend- refer to Chapter 6

Unique Tree List

- PT-F1 Pruning Deciduous Trees
- PT-F2 Pruning Drop-Crotch
- PT-F3 Street Tree Spacing and Location Requirements
- PT-F4 Tree and Shrub Detail

UNIQUE TREE LIST

Madrona	<u>Arbutus menziesii</u>
Rhododendron	<u>Rhododendron macrophyllum</u>
Quaking Aspen	<u>Populus tremuloides</u>
Soapberry	<u>Shepherdia canadensis</u>
Red Currant	<u>Ribes sanguineum</u>
Collomia	<u>Collomia grandiflora</u>
Goldenrod	<u>Solidage canadensis</u>



City of Port Townsend - Public Works Department Standard Detail

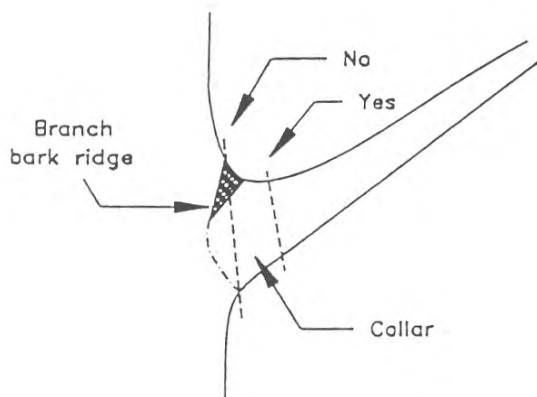

When removing a branch, always cut outside the branch bark ridge and collar. Do not make flush cut.

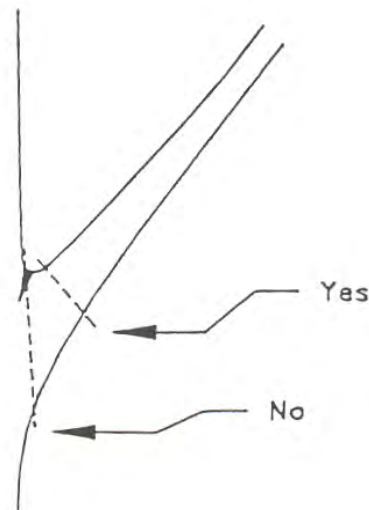

Branches that do not have a distinct collar should be cut at a right angle to the branch outside the branch bark ridge.

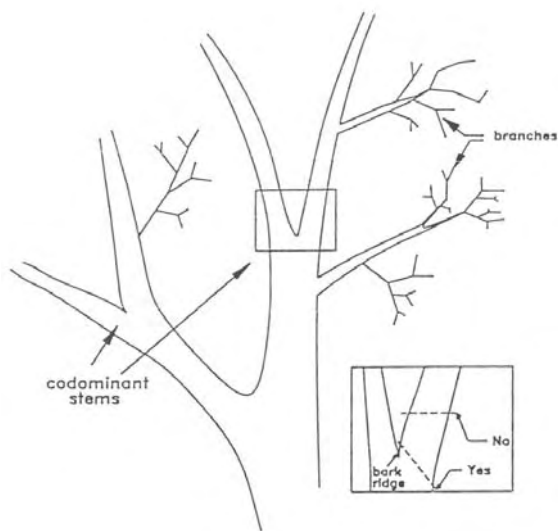

Trees may have co-dominant stems, as shown above on the left. If a co-dominant stem must be removed, cut at an angle outside of the bark ridge. Avoid leaving any stubs.

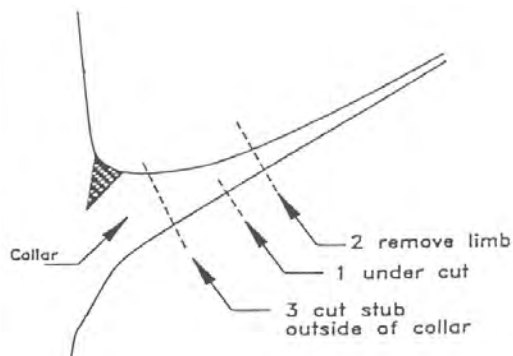

When removing heavy limbs, first make an undercut several inches outside of the collar. Then remove the limb by a second cut an inch or so outside of the first cut. Remove stub with a third cut.

Date: 7/18/95

City of Port Townsend
181 Quincy Street, Suite 301
Port Townsend, WA 98368

No.	Date	Revision	By	Apvd

Pruning
Deciduous Trees

Detail: PT-F1



City of Port Townsend - Public Works Department

Standard Detail

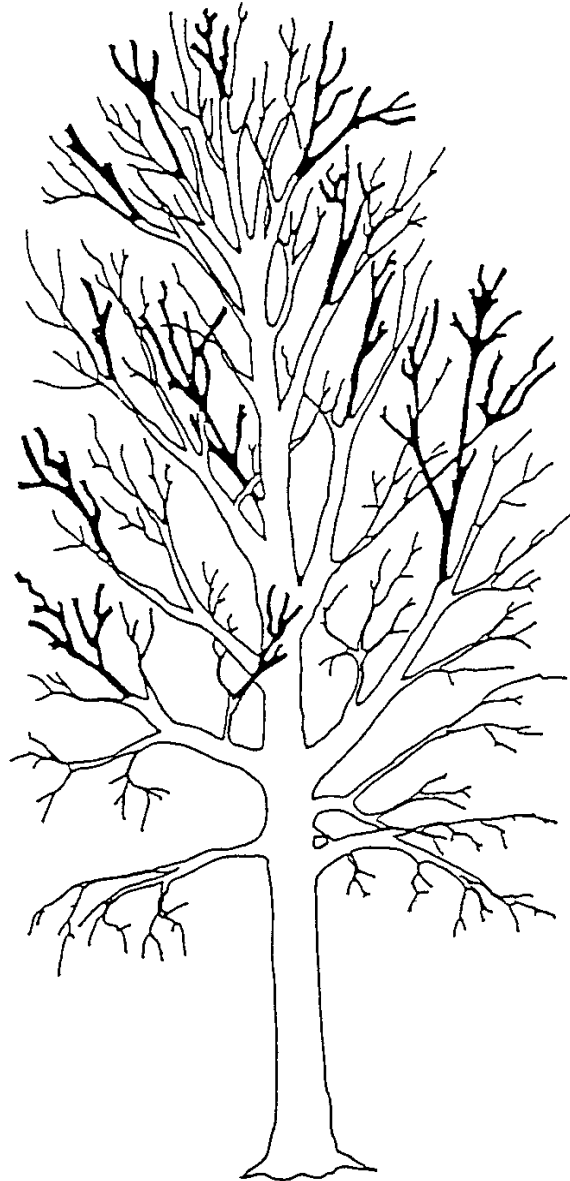

This illustration shows proper drop-crotch pruning. In each case a leader at least 1/3 the diameter of the stem from which it grows is allowed to remain. This prevents or reduces latent bud growth and thus reduces unwanted waterspouts. After drop-crotch pruning the tree is thinned and somewhat reduced in size but does not appear to be heavily pruned or sheared.

Date: 7/18/95

City of Port Townsend
181 Quincy Street, Suite 301
Port Townsend, WA 98368
Phone: (360) 385-7212

No.	Date	Revision	By	Apvd

Pruning
Drop-Crotch

Detail:

PT-F2



City of Port Townsend - Public Works Department

Standard Detail

Hedges are not allowed between the sidewalk and curb, and must be planted at least 5 feet in back of the sidewalk.

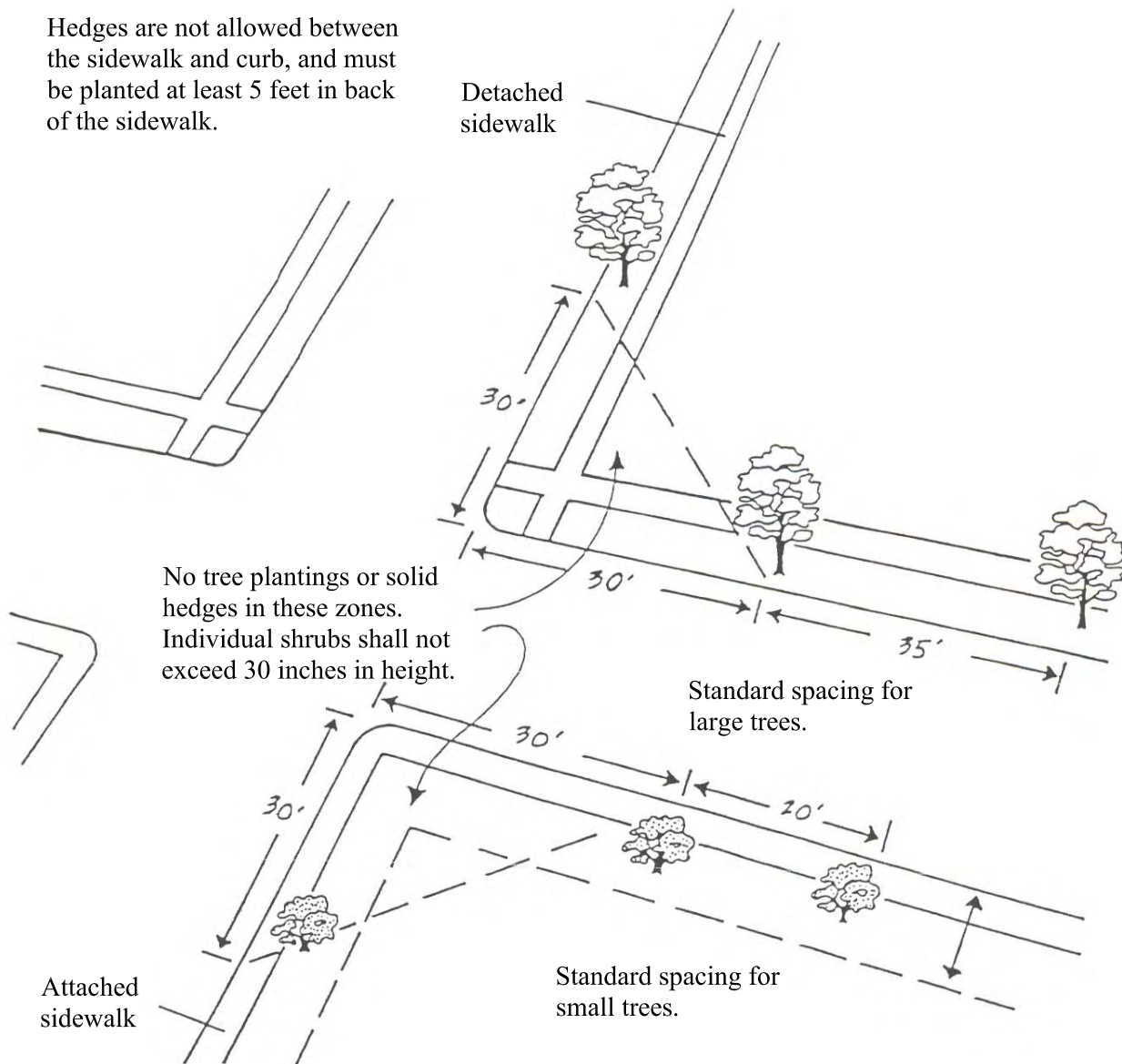

Almost all streets within the city have rights-of-way that extend back of the curb line. This area is public property and is generally used for utilities, walks and landscaping. The width of this right-of-way area varies considerably in different sections of town.

Date: 7/18/95

City of Port Townsend
 181 Quincy Street, Suite 301
 Port Townsend, WA 98368

No.	Date	Revision	By	Apvd

Street Tree Spacing
 and Location Requirements

Detail: PT-F3



City of Port Townsend - Public Works Department

Standard Detail

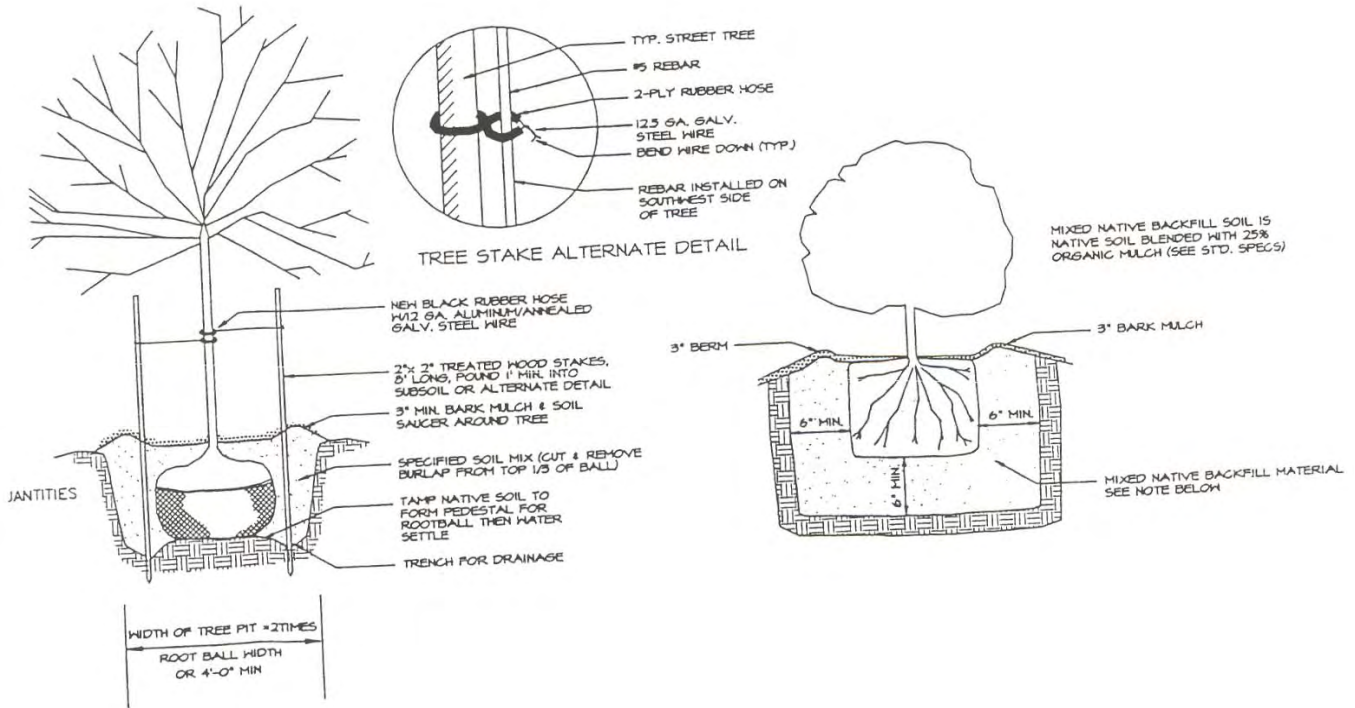

Date: 7/18/95

City of Port Townsend
 181 Quincy Street, Suite 301
 Port Townsend, WA 98368

No.	Date	Revision	By	Apvd

Tree and
Shrub Detail

Detail: PT-F4

**Department of Public Works
Permit Applications, Forms and Information Materials**

1. Development Checklist
2. Technical Conference Application
3. Street Development - Minor Improvement Permit Application
4. Street Development & Utility Development Permit Application
5. Project Review Checklist
6. Latecomer Agreement: Water/Sewer Line
7. Street Development Reimbursement Agreement
8. Conveyance of Public Facilities
9. Map Request
10. As-Built Example - Water Service Connection
- Sewer Service Connection
11. Erosion & Sediment Control Practices - Minimum Requirements for Clearing, Grading, Filling and Drainage Facilities



PUBLIC WORKS DEPARTMENT DEVELOPMENT CHECKLIST

NAME OF DEVELOPMENT _____

DEVELOPER _____ PROJECT NO. _____

CONTACT PERSON _____ PHONE _____

ENGINEER _____ PHONE _____

CONTRACTOR _____ PHONE _____

- | | |
|---|--|
| _____ 1. Initial discussion and Technical Conference, as needed. | _____ 15. Temporary Erosion Control in place. |
| _____ 2. First submittal (draft plans)
a. Street Development and/or Utility Development Permit Application
b. Three (3) sets of plans, specs, and estimates | _____ 16. Construction starts. |
| _____ 3. SEPA and ESA complete, if applicable. | _____ 17. Ongoing inspection and testing (compaction, water quality, pressure testing, as needed). |
| _____ 4. Proportionate share determination, if applicable | _____ 18. Construction completed. |
| _____ 5. Plans reviewed for compliance by City and preliminary check prints returned to Developer. | _____ 19. Final inspection by City. |
| _____ 6. Second submittal (final plans)
a. Three (3) sets of final plans | _____ 20. Punch list complete. City approval of installation. |
| _____ 7. City submits plans to DOE and/or Department of Health for approval, where appropriate. | _____ 21. Paperwork completed
a. As-built and testing records provided to the City.
b. Developer furnishes City an executed Conveyance of Public Facilities Document
c. Easements received and recorded.
d. Public Facilities Maintenance Bond received from Developer, if applicable.
e. Latecomer Agreement finalized, if applicable. |
| _____ 8. Public Works approves the permit and plans for construction. | _____ 22. Developer receives letter of acceptance of sewer, water, street, and/or storm drain facilities for maintenance and operation by City. |
| _____ 9. Developer obtains all necessary County, State, and/or Federal permits and pays all fees. | _____ 23. System(s) approved for hookups and public use by City. |
| _____ 10. Developer pays permit and initial inspection. | _____ 24. Final warranty inspection made by City prior to end of twelve (12) month warranty period. |
| _____ 11. Developer's contractor provides proof of insurance and bonds, as required. | _____ 25. Release of bond by City, if applicable. |
| _____ 12. Pre-Construction Conference arranged by Developer's contractor. City inspector to be in attendance. | |
| _____ 13. Developer's contractor notifies City inspector 48 hours in advance of starting construction. | |
| _____ 14. Underground utilities location to be requested a minimum of 2 days in advance of construction by Developer's contractor. | |



PUBLIC WORKS DEPARTMENT TECHNICAL CONFERENCE APPLICATION

The Public Works **Technical Conference** is designed to provide the prospective home builder or developer with a **preliminary** estimate of potential development requirements for a specific site. The completed application will be evaluated by the Public Works Department in concert with other departments of the City, as appropriate. A fee of \$180 is charged. Fees paid may be applied toward a street and utility development permit for projects in Tier 1 if a complete permit application is received within one year of date of receipt above, unless changes to project plans or surrounding development require further review.

If you only wish to receive the location of the utilities along the property frontage, call the Utility locate service at 1-800-424-5555. Maps of water and sewer utility locations may be purchased from the Public Works Department or reviewed at the Building and Community Development office.

Owner's Name: _____ Phone: _____

Mailing Address: _____

Site Legal Description: Lot(s) _____, Block _____, _____ Addition

Zoning District _____ Tier No. _____

Proposed Project: _____ Single-Family residence(s) with _____ outbuildings

_____ Multi-Family dwelling with _____ outbuildings

_____ Mixed use, commercial or manufacturing

_____ Subdivision or PUD

Project Description: _____

The principle means of automobile access to the site is proposed to be from _____ Street.

The **area** of the entire site is _____ square feet, of which _____ square feet is to be covered with buildings, decks, etc. (Write "**NK**" if information is not known at this early stage of project planning.)

Is any part of the subject property within 200 feet of a fresh or salt water shoreline?

Yes No

Is any part of the subject property within (1) a 100-year flood plain? (2) an Environmentally Sensitive Area (ESA)?

(1) Yes No (2) Yes No

Is the property subject to any conditions placed on any prior action of the City; e.g., subdivision, short plat, variance, conditional use permit, street vacation or planned unit development? (Attach copies of any such restrictions or conditions, if available. This information can be obtained from a title company.)

Yes No

Please submit two copies each of a **Vicinity Map** and a **Scaled Site Plan**.

Sample Vicinity Map



Sample Scaled Site Plan

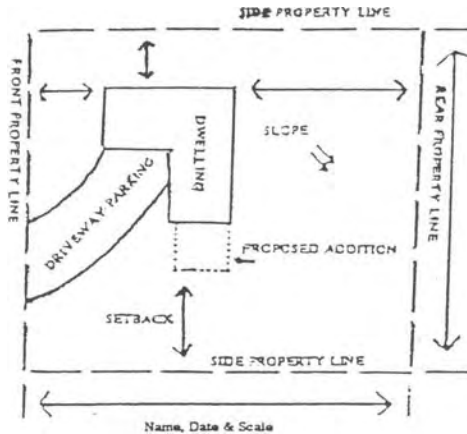

Please include the following information on the Vicinity Map and Site Plan:

On both: north arrow, street names, street rights-of-way, and easements of record.

On the Scaled Site Plan:

- _____ Plan scale
- _____ Legal description
- _____ Property lines and dimensions, including all interior lot lines
- _____ Likely location of house and accessory buildings, if known. (Please include: **setback from property lines and outline (footprint) of each proposed building.**)
- _____ Location of any existing buildings on adjacent property within 10 ft. of subject property
- _____ Off-street parking (2 spaces/single-family dwelling; 1.5 spaces/multi-family unity - each 19' x 9')
- _____ Location of existing streets and proposed street access
- _____ Slope of the land (indicate if slope is 15% or greater)
- _____ If waterfront property, show bank height, setback between proposed buildings and top of bank, all creeks, rivers, etc.
- _____ Existing and proposed utilities: service lines and pipe size (if known)
- _____ Building lines and exterior dimensions (if known)
- _____ Building and exterior dimensions (if known)

I hereby certify that all information given above and on accompanying plans is complete and accurate to the best of my knowledge. I understand that the requested comments/requirements by the City of Port Townsend regarding the above referenced project are an estimate only and may be subject to change. Additional information may become available when actual permit applications are made, or there may be discretionary approvals required under which specific mitigating conditions may be required.

The undersigned hereby saves and holds the City of Port Townsend harmless from any and all causes of action, judgements, claims, or demands, or from any liability of any nature arising from any noncompliance with any restrictive covenants, plat restrictions, deed restrictions, or other restrictions which may have been established by parties other than the City of Port Townsend.

Applicant or authorized representative

Date

For department use only.	Technical Conference Fee of \$	Receipt No.
Paid on (date)	Received for Treasurer by:	

Information Requirements for Public Works Technical Conferences

The purpose of the Public Works Technical Conference is to acquaint the applicant with the requirements of the Port Townsend Municipal Code and the Engineering Design Standards and to allow an exchange of information and ideas based upon the applicant's preliminary sketch of the proposal. Issues commonly addressed at the conference include utility and access requirements, the permitting and construction process, timing, fees, and submittal requirements. Prior to the conference, Public Works will perform an internal review of project requirements.

To schedule your Public Works Technical Conference, please submit the application form together with the required information listed below. A meeting will be scheduled within 15 calendar days of the submittal of all required information.

REQUIRED INFORMATION: You will need to submit the following information/materials prior to the technical conference:

1. The completed application form.
2. Two copies of Conceptual Site Plan Map, 8-1/2" x 11" or 11" x 17" size. Include all existing and proposed structures, lot lines (interior and exterior), general topography of site, proposed vehicle access to the site, provision of utilities, and all platted and opened roads serving the site. **FINAL DRAWINGS ARE DISCOURAGED FOR THIS TECHNICAL CONFERENCE.**
3. Identification of all land uses on adjacent properties.
4. Other property owned by the applicant within 200 feet of the proposal.
5. Anything else that may be useful in evaluating the proposal (existing photos, geology reports, economic analysis, etc.) These items are not mandatory, but if you have them, please submit them with your application.
6. The application fee.

If you have any questions before submitting your application, please contact Development Review at 360-379-3208.



**CITY OF PORT TOWNSEND PUBLIC WORKS DEPARTMENT
STREET DEVELOPMENT - MINOR IMPROVEMENT PERMIT**

CONTACT NAME _____ DATE _____
ADDRESS _____ PHONE _____

LOCATION OF IMPROVEMENT

Lot(s) _____ Block _____ Addition _____
Street No. _____ Name _____

IMPROVEMENT TYPE:

Driveway Parking (1-2 spaces) Sidewalk Culvert Building drain
 Other _____

DESCRIPTION OF PROPOSED IMPROVEMENT (Attach drawings):

Signature of Applicant: _____ Date: _____

PUBLIC WORKS REQUIREMENTS:

APPROVAL OF PERMIT: _____ Date: _____

FINAL INSPECTION BY: _____ Date: _____

ACCEPTANCE OF INSTALLATION: _____ Date: _____

See attached list of selected engineering design standards; others may also apply. Call for an INSPECTION prior to any backfilling, concrete, or paving work. For questions or to schedule inspection(s), call Development Review at (360-379-3208).

For Department Use Only:	Checklist No. _____
Application Fee of _____	Paid on _____
Receipt No. _____	Initials _____
BARS NO. 110.345.810.00	Permit No. _____



**PUBLIC WORKS DEPARTMENT
STREET DEVELOPMENT and
UTILITY DEVELOPMENT PERMIT APPLICATION**

1. PROPERTY OWNER or AGENT _____
CONTACT NAME _____ PROJECT NAME (if applicable) _____
ADDRESS _____ PHONE _____

2. PROPOSED CONTRACTOR(S) _____

City Business License #(s) _____ State Contractor's License #(s) _____
Underground Utilities License #(s) _____
ADDRESS _____ PHONE _____

3. LEGAL DESCRIPTION OF PROPERTY TO BE SERVED BY STREETS and/or UTILITIES
Lot(s) _____ Block _____ Addition _____
Street No. _____ Name _____
Other _____

4. PROPOSED IMPROVEMENTS _____

Tier 1, 2, or 3 _____

5. REASON FOR PROPOSED STREET DEVELOPMENT OR UTILITY INSTALLATION (Check all that apply.)

STREET	SEWER	WATER	STORMWATER	MISCELLANEOUS
<input type="checkbox"/> New street(s)	<input type="checkbox"/> Sewer main	<input type="checkbox"/> Water main	<input type="checkbox"/> Stormwater main	<input type="checkbox"/> Paving repairs
<input type="checkbox"/> Curb & gutter	<input type="checkbox"/> Srvc Connection	<input type="checkbox"/> Srvc Connection	<input type="checkbox"/> Catchbasin	<input type="checkbox"/> Utility installation
<input type="checkbox"/> Repair exst. street	<input type="checkbox"/> Maintenance	<input type="checkbox"/> Fire hydrant	<input type="checkbox"/> Roadway ditch	<input type="checkbox"/> Splice pit
<input type="checkbox"/> Other _____	hole	<input type="checkbox"/> Biofiltration swale	<input type="checkbox"/> Other _____	<input type="checkbox"/> Other _____

6. DATE WORK IS TO COMMENCE _____ DATE WORK IS TO BE COMPLETED _____

7A. DOES THE PROJECT SERVE EXISTING CUSTOMERS? Yes No

7B. WILL THIS PROPOSAL SERVE VACANT PROPERTIES OTHER THAN THE PROJECT SITE? _____
____ (If yes, attach list of sites which could be served.)

8. IS A LATECOMER AGREEMENT PROPOSED? Yes No If yes, attach proposed benefit area.

9. ENVIRONMENTAL QUESTIONS

Is the Environmentally Sensitive Areas (ESA) determination complete? _____

Is SEPA determination complete? _____

Is there standing water within 200 ft of the project site during the rainy season? _____

Will any significant vegetation be removed? _____ If yes, describe and show on plans.

10. OTHER PERMITS

List other permits applied for: _____

11. PLANS AND SPECIFICATIONS

Scaled plans of the proposed improvements must be included with this application. Engineered plans may be required. The plan shall indicate how the engineering design standards are met. The plan shall include the street(s) to be improved beginning with the nearest existing opened street. In the case of utility installation, the plan shall include the street(s) in which the utilities will be installed, from the point of extension to termination, including maintenance holes, hydrants, etc., and how the service connections will be made. VEGETATION TO BE REMOVED, AND TYPES, MUST BE IDENTIFIED ON THE PLAN AND ATTACHED TO THIS APPLICATION.

I request that the engineering design be performed by the City of Port Townsend. My project is in Tier 1 and involves extensions of water, sewer or, streets of less than 1 block (260 feet).

12. BOND/ESCROW (if applicable): Describe bond arrangements (attach bond) or escrow instructions.

13. OTHER:

Signature of Applicant: _____ Date: _____

Received By _____ Date: _____
Public Works Department

For Department Use Only:	Checklist No. _____
Application Fee of _____	Paid on _____
Receipt No. _____	Initials _____
BARS NO. 110.345.810.00	Permit No. _____

<i>Further BCD Review is required for:</i>	
SEPA <input type="checkbox"/> yes <input type="checkbox"/> no	ESA <input type="checkbox"/> yes <input type="checkbox"/> no
Other _____	<input type="checkbox"/> yes <input type="checkbox"/> no
Date _____	
<i>Director, Building & Community Development</i>	

PERMIT CONDITIONS

- A. Owner and/or Owner's Agent understands that the improvements outlined in this permit must be completed and approved before final building inspection unless project phasing is approved through bond, improvement method report, or other approved means.
- B. The undersigned Owner and/or Owner's Agent hereby agree to the following:
1. That all regulations and requirements set forth by Title 12 and Title 13 of the Port Townsend Municipal Code and current amendments thereto, of the City of Port Townsend, be complied with fully and completely. The issuance of this permit and acceptance by the Owner, or agent, will be construed as prima facie evidence that the Owner, or agent, has read same and agrees to its terms and stipulations in their entirety.
 2. That the work under this permit shall be constructed in accordance with the Engineering Design Standards of the City of Port Townsend, and further, that access to the property by authorized representatives of the City of Port Townsend shall be permitted at any reasonable time for the purpose of inspection for compliance with all City regulations.
 3. That 48 hours notice will be given to all utility companies involved where work is to take place. Call 1-800-424-5555 TWO DAYS BEFORE COMMENCING WORK.
 4. That all significant vegetation must be preserved in the right-of-way unless express permission for removal is granted by the Public Works Director.
 5. The Owner and/or Owner's Agent agree that any disturbance or damage to the facilities on the existing street frontage shall be repaired to its original or better conditions. Street drainage shall be restored.
 6. The Owner and/or Owner's Agent hereby agree to safeguard the work done under this permit in such a manner as to prevent injury and/or damage to the public and the owner's/agent's employees. Such precautions shall include the employment of all necessary ditch safeguards such as lanterns, barricades and safe access or egress through the working area. The owner/agent is responsible for following all Labor & Industries standards for safety.
 7. The Owner and/or Owner's Agent agree to obtain and maintain, at no cost or liability to the City, any other permits which may be required for construction work to be accomplished under this permit.
- C. The Owner and Owner's Agent hereby agree to accept full responsibility for, and to indemnify and hold harmless the City of Port Townsend, its officers, agents, and employees, from and against any liability, claims, damages, and/or costs including attorneys fees, for personal injury, death or property damage, which may arise directly or indirectly out of prosecution of the work under this permit.

- D. The Owner and/or Owner's Agent agree to take the utmost care in protecting the environment, and preventing stormwater quality problems during construction as required by the City of Port Townsend Engineering Design Standards and the Department of Ecology (DOE) Stormwater Management Manual. All disturbed areas shall be revegetated.
- E. The Owner and/or Owner's Agent shall submit to the Public Works Department, prior to final acceptance of public improvements (1) final inspection by the Public Works Department, (2) final as-builts of the improvements, and (3) a bill of sale or conveyance deed.
- F. Expiration
 - 1. All street development permits not tied to a building permit shall expire unless the work is completed within 12 months after issuance of the permit unless earlier revoked; *provided however*, that a written request for an extension may be made *prior to* expiration upon a showing to the public works director that justifiable delays or unanticipated events beyond the control of the applicant have or will preclude timely commencement or completion of the work. Any extension shall include a condition that the work will be completed within a reasonable time, not to exceed one year, as specifically set forth in the grant of the extension. Only one extension may be granted under this section.
 - 2. All street development permits tied to a building permit shall remain valid so long as the building permit remains active with the Building and Community Development Department (BCD), as shown in the BCD files. In the event the building permit becomes inactive as further set forth in the Uniform Building Code and Title 16 PTMC, the street development permit shall automatically expire.
- G. This permit may not be assigned to another person.
- H. A preconstruction conference is required prior to the start of construction; contact the Development Review Engineer to schedule this conference (360/385-3000).

PERMIT APPROVAL

Owner's Signature _____ Date _____
 (or Authorized Agent)

Approved by _____ Date _____
 City of Port Townsend

Escrow Fee Paid _____ Date _____

Received By _____
 City of Port Townsend

Bond Received _____ Date _____

Verified By _____
 City of Port Townsend



CITY OF PORT TOWNSEND - PUBLIC WORKS DEPARTMENT PROJECT REVIEW CHECKLIST

Permit No.	Applicant
Project Type	Mailing Address
Date received from PW	Phone
Public Works Department Review by: _____ Date: _____	

Project Location

Lot(s) _____ Block _____ Addition _____

Tier No. _____ Zoning District _____

Other Customers

Latecomer Agreement in effect? _____ Name: _____

Existing Customers to be served Water Sewer Streets

Streets

Development is on an existing street. Street name _____

Substandard street

No Protest required?

Improvements required?

Existing street is adequate;

Minor Activities Permit is required for driveways, drainage, etc.

New street required

Design Detail _____

Special features required _____

Access shall be from _____; see attached drawing.

New connecting streets required.

Applicant: _____

Sewer

- Existing sewer main in _____ Street Size _____
 - May be connected for service
 - An existing payback agreement may obligate applicant to reimburse the person who developed this main.* Name: _____
 - Submit Utility Development Permit Application.

- No sewer main exists adjacent to the site.
 - Applicant to construct _____ inch diameter sewer main from _____ to _____.
 - A payback agreement may be possible for partial reimbursement of your sewer main development costs.*
 - Design plans and specifications are required.
 - Existing customers may be served by the project.

- Grade from site to sewer main will not allow gravity flow; pumping system to be installed to standard specifications. _____

- Maintenance holes ("manholes") to be installed by applicant at termination and each intersection of main. Location: _____
- As the closest existing sewer main is further than 500 ft. from property and property is greater than one acre, septic system would be acceptable with valid septic permit from the Jefferson County Health Department.

FOR COMMERCIAL / MANUFACTURING ONLY

- Pretreatment needed?
- Grease trap required?
- Additional information needed: _____

Comments: _____

* Please contact the Public Works Department regarding payback agreements, 385-7212.

Project Review Checklist

Applicant: _____

Water

- Estimated water pressure _____.
- Estimated water use _____.
- Required meter size _____.
- Existing water main in _____ Street may be connected for service. (See attached drawing for location of service.)
 - Booster pump suggested / required.
 - Pressure reducing valve suggested.
 - An existing payback agreement may obligate you to reimburse the person who developed this main.*
 - Submit water service application
- No water main exists adjacent to site.
 - Construct _____ inch diameter water main from _____ to _____.
 - A payback agreement may be possible for partial reimbursement of your water main development costs.*

Comments: _____

Fire Hydrants

- Existing fire hydrant is within 250 ft.- Location _____ Flow test _____ gpm
 - Adequate flow
 - Inadequate flow
- The nearest hydrant is further than 250 ft.
 - A hydrant shall be installed at _____.

Comments: _____

* Please contact the Public Works Department regarding payback agreements, 385-7212.

Project Review Checklist

Applicant: _____

Drainage

EXISTING DRAINAGE

- Is the site within a historical flooded area? _____ ESA? _____
- Is there open drainage across site? _____
- Total impervious surface area is _____ sq. ft.; _____ % of total area.
 - Drainage plan required
 - Drainage plan not required

- Install a _____ inch diameter culvert under driveway at drainage ditch.
- Submitted drainage plan dated _____ is approved. incomplete (see comments).

Comments: _____

Project Review Checklist

Applicant: _____

General Project Requirements

Engineered plans required? Yes No

Other

Project Review Checklist

Applicant: _____

Fees

Permit fee \$ _____ + _____ hours @ \$ _____/hour = \$ _____

Inspection Fee (Includes 2 hours of inspection)* \$ _____

Water Connection _____ (tap size) \$ _____

or Meter Drop in _____ (size)

System Development Charges
Water \$ _____

Sewer \$ _____

TOTAL \$ _____

Engineering - if designed by the City of Port Townsend

Water line extension @ \$200 \$ _____

Sewer line extension @ \$200 \$ _____

Street @ \$200 \$ _____

TOTAL \$ _____

* More than 2 hours inspection will be billed at \$35 /hour.

AFTER RECORDING RETURN TO:
Public Works Department
181 Quincy Street, Suite 301
Port Townsend, WA 98368

Abbreviated legal description: _____ (complete legal description is on page 2 of this document) Affects Assessor's Tax Parcel Nos.

Latecomer Agreement: [Water/Sewer] Line

This Agreement is made this ___ day of _____, 20___, by and between _____ [name and address of reimbursee], referred to as "Contractor" for convenience, and the **City of Port Townsend**, a Washington municipal corporation and statutory city of the second class, referred to as "City" for convenience.

As required by the City, Contractor has constructed or caused to be constructed a ___-inch [water/sewer] line and related facilities ("the utility line") connected to the City's [water/sewer] system in order to extend service to the area in which Contractor's real property is located.

The construction of the utility line by Contractor will provide a benefit to certain other real property not owned by Contractor in the area of the utility line that is adjacent to or likely to require a connection to the utility line in order to be developed.

Contractor and the City desire to enter into an Agreement, pursuant to RCW 35.91, as amended, and PTMC Chapter 13.28, to partially reimburse Contractor for the costs of constructing the utility line. PTMC Chapter 13.28 is incorporated herein by this reference.

Now, therefore, Contractor and the City agree as follows:

1. Utility Line Described. The utility line constructed by Contractor is approximately ___ feet in length beginning at its connection to the City's existing [water/sewer] system at _____ and then running in a _____ direction in the right-of-way for _____ Street to _____ Street within the [water/sewer] service area of the City of Port Townsend.

2. Reimbursement Obligation. Until the expiration of this Agreement, Contractor and the authorized assigns of Contractor shall be reimbursed by the owner of real property within the benefit reimbursement area described herein that is subsequently connected to or uses the utility line; a parcel that is not included in the benefit reimbursement area may not connect to the utility line.

3. Term Modification. This Agreement shall be in effect for 15 years from the date first set forth above, or until such time as Contractor has received all reimbursements to which Contractor is entitled by this Agreement, whichever shall first occur. If the City Public Works Director determines that all or any portion of the utility line is rendered useless by reason of redesign or reconstruction, then the City's obligation to collect reimbursements pursuant to this Agreement shall terminate to the extent of such determination.

4. Limitations. Extensions of the utility line are not subject to the reimbursement provisions of this Agreement. The reimbursement provisions of this Agreement do not apply to any real property along the utility line purchased from Contractor after construction of the utility line. If two or more adjoining parcels within the benefit reimbursement area are under the same ownership, and a connection or use of the utility line benefits improvements legally situated entirely within the boundaries of less than all such adjoining parcels, the reimbursement amount shall be calculated based on the parcel(s) within which the improvements are situated.

5. Benefit Reimbursement Area; Amounts. In accordance with PTMC 13.28.070, a benefit reimbursement area has been determined to include the following parcels of real property, each of which is subject to the indicated latecomer reimbursement amount:

A. Lots ___ and ___ in Block ___ of the plat of _____ Addition, as per plat recorded in Volume ___ of Plats, page ___, records of Jefferson County, Washington.

B. Lots ___ through ___ in Block ___ of the plat of _____ Addition, as per plat recorded in Volume ___ of Plats, page ___, records of Jefferson County, Washington.

The reimbursement amount for the foregoing is to be calculated at the rate of \$ ___ per front foot.

The amounts set forth above are subject to an administrative surcharge, payable to the City by the connecting property owner pursuant to PTMC 13.28.130B. Unless otherwise specified in this Agreement,

the amount of surcharge is 10% of the reimbursement amount, or \$20.00, whichever is greater.

6. Certificate of Payment. Upon request, the City shall provide a certificate of payment to an owner of a parcel of real property for which the payment due to pursuant to this Agreement has been received by the City; the certificate may be recorded at the owner's expense.

7. Effectiveness. The provisions of this Agreement shall not be effective with respect to any owner of real property other than Contractor unless this Agreement has been recorded in the office of the Jefferson County Auditor prior to the time there is a connection to or use of the utility line by an owner of real property other than Contractor.

8. Acceptance; Contractor's Warranty. Upon completion of the utility line by Contractor, the city may approve the construction in writing and thereby accept the utility line as a facility of the City. To be accepted, the utility line must conform to all applicable specifications, standards, regulations, laws and ordinances. As a condition of acceptance, Contractor shall warrant that the utility line is fit for use as part of the City's water distribution system. For the period of 1 year measured from the date of acceptance, Contractor shall remain responsible for all work found to be defective. Subject to the foregoing, the City shall bear all maintenance and operation costs of the utility line from and after the date of acceptance. In consideration of the benefits to be derived from City utility service, and in further consideration of the terms and conditions of this Agreement, Contractor agrees to execute and deliver to the City such documents as may be necessary to transfer ownership of the utility line to the City upon acceptance.

9. Utility Charges. From and after the date the utility line is put into service, the City shall charge for its use such rates and charges as the City may by law be authorized to establish. Billing for utility charges attributable to the utility line may not be deemed or construed to constitute acceptance of the utility line by the City.

10. Indemnification; Hold Harmless. If any lien against the utility line is asserted after its acceptance by the City and the basis for such lien arose on or prior to the date of acceptance, Contractor shall indemnify and save harmless the City from any loss on account thereof. During construction of the utility line and for the duration of the 1 year warranty period described above, Contractor shall indemnify, defend and hold harmless the City from any and all liability, claims and costs, including but not limited to reasonable fees for legal services, arising directly or indirectly out of the construction or use of the utility line. If the city incurs any expenses in defense against any such lien or claim, or in taking any other action that is required of Contractor under this Agreement, the City shall have a lien in the full amount thereof against any funds then or thereafter collected by the City pursuant to this Agreement.

11. Enforcement. No person or legal entity may be granted a permit or otherwise be authorized to connect to the utility line during the term of this Agreement without first paying to the City, in addition to any and all other costs and charges made or assessed for such connection or for any other utility line or facility constructed in connection therewith, the amount set forth in this Agreement. If any connection is made to the utility line without such payment having first been made to the City, the City may remove or cause to be removed such unauthorized connection and all connected tile or pipe located in the public right-of-way, and dispose of such materials so removed without any liability whatsoever.

12. Payment Transmittal. Payments received by the City pursuant to this Agreement shall be transmitted to Contractor by Certified Mail at the address furnished by Contractor within 60 days of receipt, less the administrative surcharge authorized by PTMC 13.28.130B. It is the responsibility of the Contractor to advise the City of any change in Contractor's mailing address at all times during the term of this Agreement. Payments returned to the City unclaimed shall be held for 6 months and then deposited in the maintenance fund of the relevant utility, or as allowed by applicable law. If there is a valid assignment or transfer of Contractor's rights, whether voluntary or involuntary, the city shall thereafter pay any benefits accruing, after notice, to the successor of Contractor.

13. Binding Effect. This Agreement shall be binding upon Contractor, Contractor's heirs, personal representatives, successors in interest and assigns, and the successors in interest and assigns of the City.

14. Creation of Lien. The terms and conditions contained in this Agreement constitute covenants running with the land. The amount of any payment due pursuant to this Agreement until fully paid shall be a lien against the real property connected to the utility line and such lien shall have priority over all other liens and encumbrances except liens for taxes or special assessments imposed by governmental authority.

15. General Provisions. This Agreement shall be governed by the laws of the State of Washington. Venue for any legal action regarding this Agreement shall be Jefferson County. If any term or provision of this Agreement is in whole or in part held to be invalid or unenforceable by any Court of

competent jurisdiction, the remainder of this Agreement shall not be affected thereby, and shall continue in full force and effect. The failure of the City to take action to enforce any term or condition of this Agreement in any particular instance shall not be deemed or construed to be a waiver of the right of the City to take such action in the future.

In Witness Whereof, Contractor and the City have signed this Agreement as of the date first appearing above.

Contractor

City of Port Townsend

Mayor

Attest:

Approved as to form:

City Clerk

City Attorney

After Recording Return To:
Public Works Department
181 Quincy Street, Suite 301
Port Townsend WA 98368

Abbreviated legal descriptions:
Affects Assessor's Tax Parcel Nos.

Street Development Reimbursement Agreement

This Agreement is made this ___ day of _____, 20___, by and between _____ (name and address of reimburse), referred to as "Contractor" for convenience, and the **City of Port Townsend**, a Washington municipal corporation and statutory city of the second class, referred to as "City" for convenience.

As required by City ordinances, Contractor is obligated to construct certain street improvements, as defined in PTMC 12.26.020 ("the improvements"), in order to develop Contractor's real property.

The construction of the improvements by Contractor will provide a benefit to the owners of other real property in the vicinity of the improvements to the extent that such owners will not be required to install similar improvements as a prerequisite to development because the improvements were constructed pursuant to this Agreement.

Contractor and the City desire to enter into an Agreement, pursuant to RCW 35.72, as amended, and PTMC Chapter 12.26, to partially reimburse Contractor for the cost of constructing the improvements. PTMC Chapter 12.26 is incorporated herein by this reference.

Now, therefore, Contractor and City agree as follows:

1. Description of Improvements. The following is a summary of the improvements that shall be constructed by Contractor in accordance with this Agreement:

(A) The right of way for _____ Street, as dedicated in _____ Addition to the City of Port Townsend, as per plat recorded in Volume ___ of Plats, page ___, records of Jefferson County, Washington, and as dedicated in _____ Addition to the City of Port Townsend, as per plat recorded in Volume ___ of Plats, page ___, records of Jefferson County, Washington, is to be paved to a width of ___ feet;

(B) Vegetated swales for the control and conveyance of stormwater runoff are to be constructed along the sides of the improved roadway;

(C) A traffic signal is to be installed at the intersection of _____ Street and _____ Avenue; and

(D) Turning lanes within the right of way for _____ Avenue.

The foregoing summary does not validate or modify the detailed plans and drawings of the entire improvements prepared and stamped by a professional engineer, as submitted to the Public Works Director.

All of the foregoing improvements shall be constructed by the Contractor in accordance with such plans and drawings as may be approved by the Public Works Director, and all municipal ordinances, state and federal statutes, and all rules and regulations promulgated pursuant to such ordinances and statutes.

2. Reimbursement Obligation. Until the expiration of this Agreement, Contractor and the authorized assigns of Contractor shall be reimbursed by the owner of real property within the benefit reimbursement area described herein that is permitted by the City to be developed without being required as a condition of development to construct improvements similar to those described herein due to the fact that such improvements were constructed by Contractor in accordance with this Agreement.

3. Term; Modification. This Agreement shall be in effect for 15 years from the date first set forth above, or until such time as Contractor has received all reimbursements to which Contractor is entitled by this Agreement, whichever shall first occur. If the City Public Works Director determines that all or any portion of the improvements is rendered useless by reason of redesign or reconstruction, then the City's obligation to collect reimbursements pursuant to this Agreement shall terminate to the extent of such determination.

4. Limitations. An extension of any of the improvements is not subject to the reimbursement provisions of this Agreement. The reimbursement provisions of this Agreement do not apply to any property within the benefit reimbursement area described herein that is owned by Contractor at the time of construction of the improvements and is subsequently purchased from Contractor.

5. Cost Estimate; Adjustment. Contractor submitted an itemized estimate of the total projected cost of the improvements, as prepared and certified by either a licensed contractor or a licensed engineer. The reimbursement amount set forth herein is based on this estimate. As provided in PTMC 12.26.100, upon a showing of good cause by Contractor, this Agreement is subject to modification to include Contractor's cost overruns to a maximum of ten percent of the estimated total projected cost. If the actual cost of constructing the improvements is no less than ten percent lower than the estimated total projected cost, the City Public Works Director shall recalculate the benefit reimbursement amounts, reducing them accordingly.

6. Benefit Reimbursement Area; Amounts. In accordance with PTMC 12.26.070, a benefit reimbursement area has been determined to include the parcels of real property described in the attached Exhibit A, which is made a part of this Agreement by this reference. During the term of this Agreement, the owner of each parcel shall be required to pay the indicated reimbursement amount prior to the issuance of a building permit, unless otherwise provided herein. Such amounts are subject to an administrative surcharge, payable to the City by the connecting property owner pursuant to PTMC 12.26.130B; the amounts of such surcharge is 10% of the reimbursement amount, or \$20.00, whichever is greater.

7. Certificate of Payment. Upon request, the City shall provide a certificate of payment to an owner of a parcel of real property for which the payment due pursuant to this Agreement has been received by the City; the certificate may be recorded at the owner's expense.

8. Effectiveness. The provisions of this Agreement shall not be effective with respect to any owner of real property other than Contractor unless this Agreement has been recorded in the office of the Jefferson County Auditor.

9. Acceptance; Contractor's Warranty. Upon completion of the improvements by Contractor, the City may approve the construction in writing and thereby accept the improvements as facilities of the City. To be accepted, the improvements must conform

to all applicable specifications, standards, regulations, laws and ordinances, including, but not limited to, PTMC Chapter 12.04. As a condition of acceptance, Contractor shall warrant that the improvements are fit and suitable for use as facilities of the City. For the period of 1 year measured from the date of acceptance, Contractor shall remain responsible for all work found to be defective. If the Public Works Director has required bonding, Contractor shall maintain such bonding for such period. Subject to the foregoing, the City shall bear all maintenance and operation costs of the improvements after the date of acceptance in the manner provided in PTMC Chapter 12.04. In consideration of the benefits to be derived from City services, and in further consideration of the terms and conditions of this Agreement, Contractor agrees to execute and deliver to the City such documents as may be necessary to transfer ownership of the improvements to the City upon acceptance, together with all necessary easements or other property interests.

10. Indemnification; Hold Harmless. If any lien against the improvements is asserted after acceptance by the City and the basis for such lien arose on or prior to the date of acceptance, Contractor shall indemnify and save harmless the City from any loss on account thereof. During the construction of the improvements and for the duration of the 1 year warranty period described above, Contractor shall indemnify, defend and hold harmless the City from any and all liability, claims and costs, including but not limited to reasonable fees for legal services, arising directly or indirectly out of the construction or use of the improvements. If the City incurs any expense in defense against any such lien or claim, or in taking any other action that is required of Contractor under this Agreement, the City shall have a lien in the full amount thereof against any funds then or thereafter collected by the City pursuant to this Agreement.

11. Enforcement. No person or legal entity owning property within the benefit reimbursement area described herein may be granted a building permit during the term of this Agreement without first paying to the City, in addition to any and all other costs and charges made or assessed for the use of any of the improvements constructed in connection herewith, the amount set forth in this Agreement. If the City Public Works Director determines that a condition exists in violation of PTMC Chapter 12.26, or any other code or standard required to be adhered to by this Agreement, such individual is authorized to take such corrective or other action to discontinue such condition pursuant to procedures set forth in PTMC Chapter 20.10.

12. Payment Transmittal. Payments received by the City pursuant to this Agreement shall be transmitted to Contractor by Certified Mail at the address furnished by Contractor within 60 days of receipt, less the administrative surcharge authorized by PTMC 12.26.130B. IT is the responsibility of Contractor to advise the City of any change in Contractor's mailing address at all times during the term of this Agreement, and the City has no obligation to locate Contractor or any assignee. Payments returned to the City unclaimed shall be held for 6 months and then be credited as revenue of the street fund or of the relevant utility, or as allowed by applicable law. If there is a valid assignment or transfer of Contractor's rights, whether voluntary or involuntary, the City shall thereafter pay any benefits accruing, after notice, to the successor of the Contractor.

13. Binding Effect. This Agreement shall be binding upon Contractor, Contractor's heirs, personal representatives, successors in interests and assigns, and the successors in interest and assigns of the City.

14. Creation of Lien. The terms and conditions contained in this Agreement constitute covenants running with the land. The amount of any payment due pursuant to this Agreement until fully paid shall be a lien against the real property benefited by the improvements, as described herein, and such lien shall have priority over all other liens and encumbrances except liens for taxes or special assessments imposed by governmental authority.

15. General Provisions. This Agreement shall be governed by the laws of the State of Washington. Venue for any legal action regarding this Agreement shall be Jefferson County. If any term or provision of this Agreement is in whole or in part held to be invalid or unenforceable by any Court of competent jurisdiction, the remainder of this Agreement shall not be affected thereby, and shall continue in full force and effect. The failure of the City to take action to enforce any term or condition of this Agreement in any particular instance shall not be deemed or construed to be a waiver of the right of the City to take such action in the future.

In Witness Whereof, Contractor and the City have signed this Agreement as of the date first appearing above.

Contractor

City of Port Townsend

Mayor

Attest:

Approved as to form:

City Clerk

City Attorney



**CONVEYANCE OF PUBLIC FACILITIES
to
CITY OF PORT TOWNSEND**

FOR VALUABLE CONSIDERATION, receipt of which is hereby acknowledged, _____ hereby grants, bargains, sells, and conveys to the CITY OF PORT TOWNSEND the following described property located in JEFFERSON COUNTY, WASHINGTON: All of the sewer, streets, alleys, storm drains, and/or water systems heretofore constructed to serve the plat or development of _____ as recorded in Volume _____, Page _____ of Plats, records of Jefferson County, Washington. The sewer, storm drain, and/or water systems are more specifically described as follows:

Pipe Size	Length	Material	On or In	From	To	Value
						\$
						\$
						\$
						\$
						\$
Streets						
						\$
						\$
						\$
						\$

Including maintenance holes, tees, wyes, valves, hydrants, blowoffs, detention/retention facilities, pipelines, water lines, streets, alleys, and other appurtenances, all within public right-of-way and/or easements.

In making the conveyance, the undersigned warrants to the CITY OF PORT TOWNSEND that all claims for labor materials, or taxes, and other indebtedness that might be a lien against said public facilities, have been paid, and further guarantees to the CITY OF PORT TOWNSEND for the period of twelve (12) months from the date of this instrument, that the said public facilities be free of defects in labor and materials.

The undersigned further warrants to the CITY OF PORT TOWNSEND that he/she/they own said public facilities free and clear of all encumbrances, and has/have full right, title, and right to dispose of same.

DATED this _____ day of _____, 19____.
GRANTOR(S) _____

STATE OF WASHINGTON)
) SS:
COUNTY OF JEFFERSON)

I certify that I know or have satisfactory evidence that _____ signed this instrument, on oath stated that he/she/they was/were authorized to execute the instrument, and acknowledged it to be the free and voluntary act of _____ for the uses and purposed mentioned in this instrument.
SUBSCRIBED AND SWORN to before me this _____ day of _____, 19____.

NOTARY PUBLIC in and for the
State of Washington, residing at

My appointment expires _____



City of Port Townsend - Public Works Department

Standard Detail

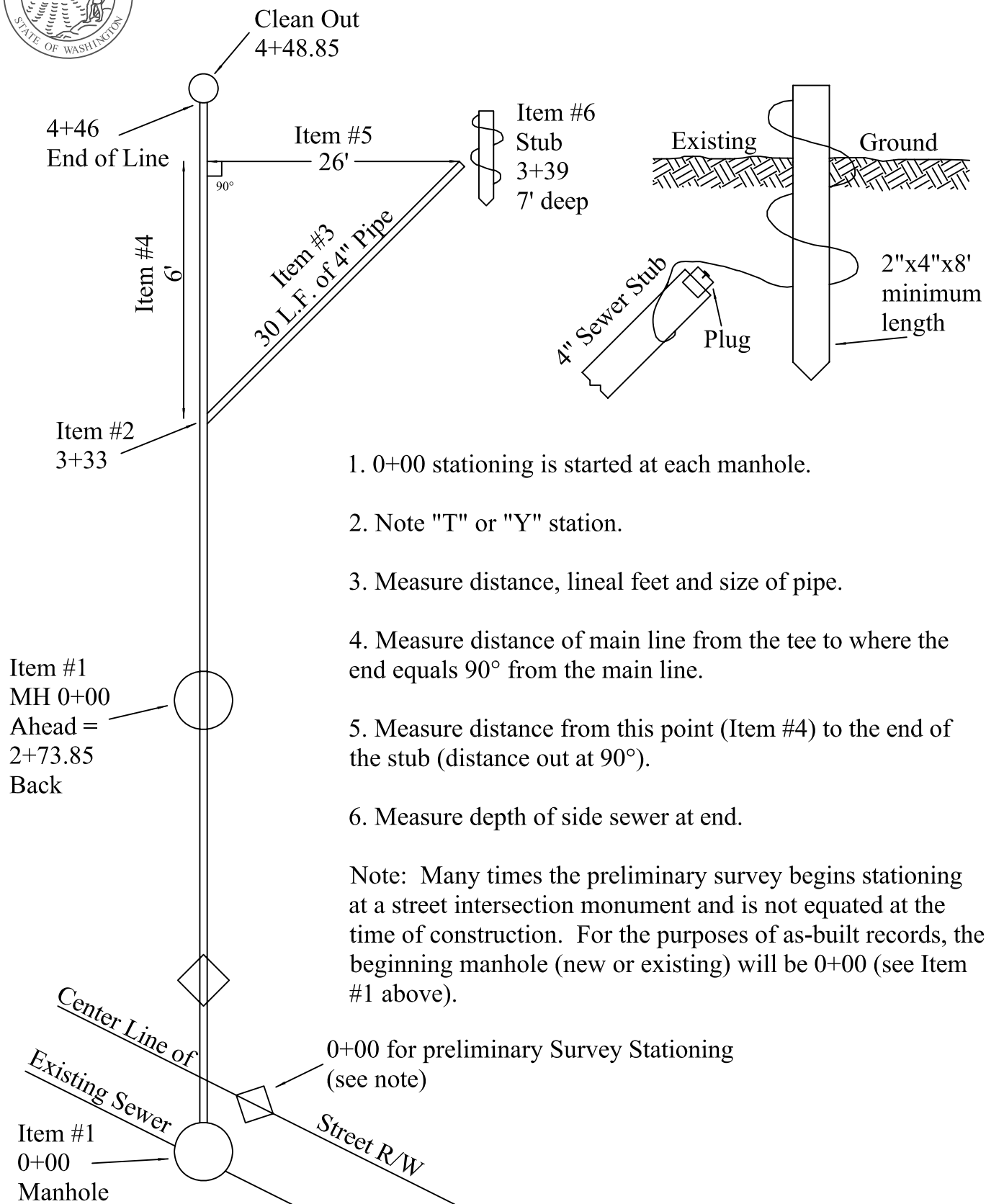

1. 0+00 stationing is started at each manhole.
2. Note "T" or "Y" station.
3. Measure distance, lineal feet and size of pipe.
4. Measure distance of main line from the tee to where the end equals 90° from the main line.
5. Measure distance from this point (Item #4) to the end of the stub (distance out at 90°).
6. Measure depth of side sewer at end.

Note: Many times the preliminary survey begins stationing at a street intersection monument and is not equated at the time of construction. For the purposes of as-built records, the beginning manhole (new or existing) will be 0+00 (see Item #1 above).

Date: 7/18/95

City of Port Townsend
 181 Quincy Street, Suite 301
 Port Townsend, WA 98368

No.	Date	Revision	By	Apvd

As Built
Sewer

Detail: PT-AB1

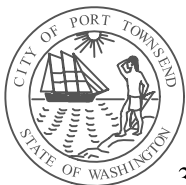

City of Port Townsend - Public Works Department

Standard Detail

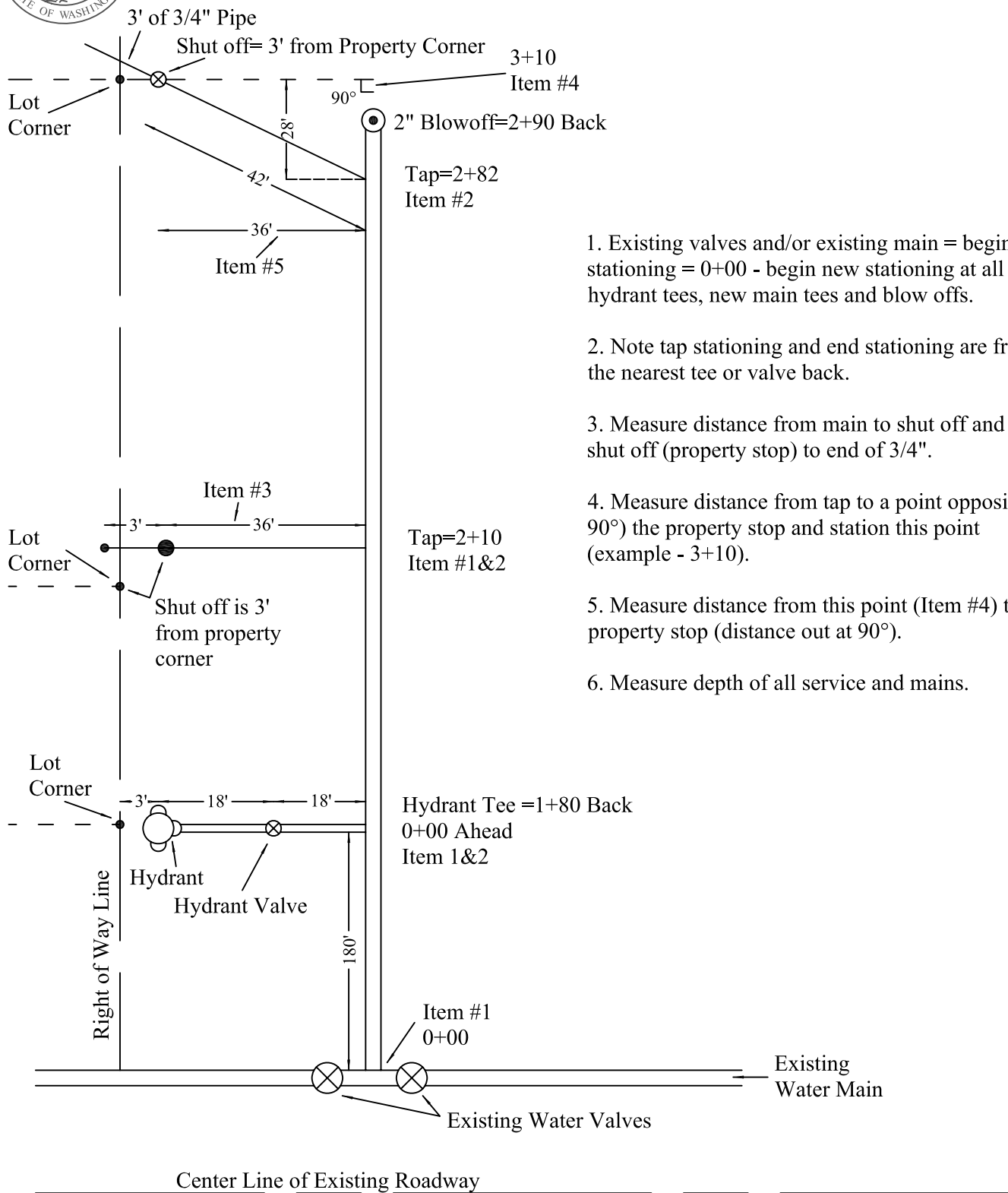

1. Existing valves and/or existing main = beginning stationing = 0+00 - begin new stationing at all hydrant tees, new main tees and blow offs.
2. Note tap stationing and end stationing are from the nearest tee or valve back.
3. Measure distance from main to shut off and from shut off (property stop) to end of 3/4".
4. Measure distance from tap to a point opposite (at 90°) the property stop and station this point (example - 3+10).
5. Measure distance from this point (Item #4) to the property stop (distance out at 90°).
6. Measure depth of all service and mains.

Date: 7/18/95

City of Port Townsend
 181 Quincy Street, Suite 301
 Port Townsend, WA 98368

No.	Date	Revision	By	Apvd

As Built
Water

Detail: PT-AB2



EROSION & SEDIMENT CONTROL PRACTICES

MINIMUM REQUIREMENTS for CLEARING, GRADING, FILLING, AND DRAINAGE FACILITIES

Land alteration and land disturbing activities such as clearing, grading, cutting, filling, and construction can create erosion and sedimentation which adversely affect the quality of our local streams, wetlands, Port Townsend Bay, and the Strait of Juan de Fuca. The goal of the following MINIMUM erosion control practices is to see that no sediment leaves the construction site. These minimum practices are to be followed for all land disturbing activities whether a separate permit or erosion and sediment control plan is required or not.

(1) **CONSTRUCTION SITE ACCESS:** Provide a clean hard surface for vehicles entering the construction site to eliminate tracking of soil onto the street. This access should be limited to one route, wherever possible. Surface materials may include quarry spalls, crushed rock, river rock, or other non-soil or non-sand materials.

Maintenance: The entrance shall be maintained in a condition which will prevent tracking or flow of mud onto public rights-of-way. This may require periodic top dressing with 2-inch stone or other approved material as conditions demand, and repair and/or cleanout of any structures used to trap sediment. All materials spilled, dropped, washed, or tracked from vehicles onto roadways or into storm drains must be removed immediately.

(2) **GRADING:** The following are the minimum standards for grading activities:

1. Grading shall not contribute to or create landslides, accelerated soil creep, or settlement of soils.
2. Natural land and water features, vegetation, drainage and other natural features of the site shall be reasonably preserved.
3. Grading shall not create or contribute to flooding, erosion, increased turbidity, or siltation of a watercourse.
4. Groundcover and tree disturbance shall be minimized.
5. Grading operations shall be conducted so as to expose the smallest practical area to erosion for the least possible time.
6. Grading shall not divert existing watercourses or drainageways.

(3) **CUTS AND FILLS** The following are the minimum standards for cutting and filling:

1. Cut slopes shall be no steeper than is safe for the intended use. Cut slopes greater than five (5) feet in height shall be no steeper than two (2) horizontal to one (1) vertical, except where approved retaining walls are to be installed.
2. Filling should only occur where the ground surface has been prepared by removal of vegetation and other suitable materials or preparation of steps where natural slopes are steeper than five to one (5 to 1). Fill slopes should not be constructed on natural slopes greater than two to one (2 to 1).
3. Fill slopes shall be no steeper than is safe for the intended use. Fill slopes greater than five (5) feet in height shall be no steeper than two (2) horizontal to one (1) vertical, except where approved retaining wall are engineered and installed.
4. Steeper cut/fills may be permitted if supported by an approved soils/geological report.
5. Cut and fill slopes shall not encroach upon adjoining property without written approval of the adjacent owner.
6. Cut and fill slopes shall be provided with subsurface and surface drainage provisions to approved discharge locations as necessary to retain the slope.
7. The faces of slopes shall be prepared and maintained to control erosion. Check dams, riprap, plantings, terraces, diversion ditches, sedimentation ponds, straw bales, other methods shall be employed where necessary to control erosion and provide safety. The erosion control measures shall be initiated or installed as soon as possible and shall be maintained by the owner.
8. Fill materials used as a structural fill shall be compacted in accordance with the requirements applicable to the future use.

(4) **STABILIZATION OF DENUDED AREAS:** All exposed and unworked soils shall be stabilized using the best management practice for the site, which can involve sod, vegetation, plastic covering, mulching, etc.

(5) **CLEAN-UP:** Persons and/or firms engaged in clearing, grading, and filling, or drainage activities shall be responsible for the maintenance of work areas free of debris or other material that may cause damage to or siltation of existing or new facilities or have the potential of creating a safety hazard.

(6) **CONTROL OF SITE RUNOFF:** Adjacent properties shall be protected from sediment by installation of (a) a silt barrier downstream of the work using a silt fence and/or hay bales; (b) a sump or basin with a filtering system to accommodate the directed runoff prior to discharge to the existing drainage facilities.

STRAW BALES:

1. Secure bales with 2 stakes or rebar driven through each bale.
2. Ends of adjacent bales shall tightly abut one another.

Maintenance:

1. Straw bale barriers shall be inspected immediately after each runoff-producing rainfall and at least daily during prolonged rainfall.
2. Close attention shall be paid to the repair of damaged bales, end runs, and undercutting beneath bales.
3. Sediment deposits should be removed after each runoff-producing rainfall.

FILTER FENCE:

1. The material used in a filter fabric fence must have sufficient strength to withstand various stress conditions and it also must have the ability to allow passage of water while retaining soil particles. The ability to pass flow through must be balanced with the material's ability to trap sediments.
2. Monofilament and non-woven geotextiles shall have an A.O.S. of 70.
3. Slit film fabrics shall have an A.O.S. of 40 to 60.
4. Inspect immediately after each rainfall, and at least daily during prolonged rainfall. Repair as necessary.
5. Sediment must be removed when it reaches approximately one third the height of the fence, especially if heavy rains are expected.
6. Any sediment deposits remaining in place after the filter fence is no longer required shall be dressed to conform with the existing grade, prepared and seeded.

IF YOU HAVE ANY QUESTIONS REGARDING THE MAINTENANCE OF THE CONSTRUCTION SITE, PLEASE CONTACT DEVELOPMENT REVIEW AT 360-379-3208.